

Axial piston variable pump A4VG series 32



- ▶ High-pressure pump for applications in closed circuits
- ▶ Size 28 to 180
- ▶ Nominal pressure 400 bar
- ▶ Maximum pressure 450 bar
- ▶ Closed circuit

Features

- ▶ Integrated auxiliary pump for boost and pilot oil supply
- ▶ Flow direction changes when the swashplate is moved through the neutral position
- ▶ High-pressure relief valves with integrated boost function
- ▶ With adjustable pressure cut-off as standard
- ▶ Boost-pressure relief valve
- ▶ Through drive for mounting of further pumps up to same size
- ▶ Large variety of controls
- ▶ Swashplate design

Contents

Type code	2
Hydraulic fluids	6
Working pressure range	8
Technical data	10
NV – Version without control module	13
HD – Proportional hydraulic control, pilot-pressure related	14
HW – Proportional hydraulic control, mechanical servo	16
DA – Automatic control, speed related	18
DG – Hydraulic control, direct operated	21
EP – Proportional control, electric	22
EZ – Two-point control, electric	24
ET – Electric control, direct operated	25
BT – BODAS electronic control	27
Dimensions, size 28	29
Dimensions, size 40	35
Dimensions, size 56	41
Dimensions, size 71	47
Dimensions, size 90	53
Dimensions, size 125	58
Dimensions, size 180	65
Dimensions, through drive	70
Overview of mounting options	83
Combination pumps A4VG + A4VG	84
High-pressure relief valves	85
Pressure cut-off	86
Mechanical stroke limiter	87
Stroking chamber pressure port X ₃ and X ₄	88
Measuring ports M _A , M _B , M _H	89
Filtration	90
Connector for solenoids	95
Rotary inch valve	96
Installation dimensions for coupling assembly	97
Installation instructions	98
Project planning notes	101
Safety instructions	102

Type code

01	02	03	04	05	06	07	08	09	10	11	12	13	14	15	16	17	18	19	20	21	22	
A4V	G			D					/	32		-	N									

Axial piston unit

01	Swashplate design, variable, nominal pressure 400 bar, maximum pressure 450 bar	A4V
----	---	-----

Operating mode

02	Pump, closed circuit	G
----	----------------------	---

Size (NG)

03	Geometric displacement, see "Technical data" on page 10	28	40	56	71	90	125	180
----	---	----	----	----	----	----	-----	-----

Control device

		28	40	56	71	90	125	180
04	Without control module	●	●	●	●	●	●	NV
	Proportional control hydraulic							
	pilot-pressure related, with inlet filtration in P ¹⁾	●	●	●	●	●	●	HD3
	mechanical servo	●	●	●	●	●	●	HW
	Automatic control, speed related							
	U = 12 V	●	●	●	●	●	●	DA1
	U = 24 V	●	●	●	●	●	●	DA2
	Hydraulic control, direct operated	●	●	●	●	●	●	DG
	Proportional control electric							
	with proportional solenoid with inlet filtration in P ¹⁾							
	U = 12 V	●	●	●	●	●	●	EP3
	U = 24 V	●	●	●	●	●	●	EP4
	Two-point control, electric							
	with switching solenoid							
	U = 12 V	●	●	●	●	●	●	EZ1
	U = 24 V	●	●	●	●	●	●	EZ2
	Electric control, direct operated							
	two pressure reducing valves (FTDRE)							
	U = 12 V	●	●	-	-	-	-	ET3
	U = 24 V	●	●	-	-	-	-	ET4
	Electric control, direct operated							
	two pressure reducing valves (DRE5)							
	U = 12 V	-	-	-	-	●	-	ET7
	U = 24 V	-	-	-	-	●	-	ET8
	BODAS electronic control ²⁾							
	U = 12 V	●	●	-	-	-	-	BT1
	U = 24 V	●	●	-	-	-	-	BT2

Pressure cut-off

		28	40	56	71	90	125	180
05	Without pressure cut-off ³⁾	●	●	-	-	-	●	-
	Pressure cut-off	●	●	●	●	●	●	D

Neutral position switch

		28	40	56	71	90	125	180
06	Without neutral position switch (without code)	●	●	●	●	●	●	
	Neutral position switch (only for HW control)	●	●	●	●	●	●	L

Mechanical stroke limiter

		28	40	56	71	90	125	180
07	Without mechanical stroke limiter (without code)	●	●	●	●	●	●	
	Mechanical stroke limiter, externally adjustable	●	●	●	●	●	●	M

Stroking chamber pressure port

		28	40	56	71	90	125	180
08	Without stroking chamber pressure port X ₃ , X ₄ (without code)	●	●	●	●	●	●	
	Stroking chamber pressure port X ₃ , X ₄	●	●	●	●	●	●	T

● = Available ○ = On request - = Not available

= Preferred program

1) Sizes 28 to 71 are designed with inlet filtration in P and X₁/X₂
2) The BT control is only permissible in combination with port plate 22 or 30, see position 15 "Port thread: Metric with O-ring seal following ISO 6149".

3) Version not available for all port plate variants, please contact us.

01	02	03	04	05	06	07	08	09	10	11	12	13	14	15	16	17	18	19	20	21	22	
A4V	G			D					/	32		-	N									

DA control valve		NV	HD	HW	DG	DA	EP	EZ	ET	BT	
09	Without DA control valve	●	●	●	●	-	●	●	●	●	1
	DA control valve, fixed setting	-	●	●	●	●	●	-	-	-	2
	DA control valve, mechanically adjustable, direction of actuation, clockwise with position lever	-	●	●	●	●	●	-	-	-	3R
	DA control valve, mechanically adjustable, direction of actuation, counter-clockwise with position lever	-	●	●	●	●	●	-	-	-	3L
	DA control valve, fixed setting, ports for pilot control device	-	●	●	-	●	●	-	-	-	7
	DA control valve, fixed setting and hydraulic inch valve mounted, control with hydraulic fluid, mineral oil-based	-	-	-	-	●	-	-	-	-	8

Series

10	Series 3, index 2																					32
----	-------------------	--	--	--	--	--	--	--	--	--	--	--	--	--	--	--	--	--	--	--	--	-----------

Direction of rotation		28	40	56	71	90	125	180	
11	Viewed on drive shaft								
	clockwise	●	●	●	●	●	●	●	R
	counter-clockwise	●	●	●	●	●	●	●	L

Sealing material		28	40	56	71	90	125	180	
12	NBR (nitrile rubber), shaft seal made of FKM (fluorocarbon rubber)	●	●	●	●	●	●	●	N

Drive shaft		28	40	56	71	90	125	180	
13	Splined shaft								
	DIN 5480								
	for single pump	●	●	●	●	●	●	●	Z
	for combination pump – 1st pump	- ⁴⁾	●	●	●	●	●	- ⁴⁾	A
	Splined shaft								
	ANSI B92.1a								
	for single pump	●	●	●	●	●	●	●	S
	for combination pump – 1st pump	- ⁵⁾	- ⁵⁾	●	●	- ⁵⁾	●	●	T
	only for combination pump – 2nd pump	-	●	-	-	●	-	-	U

Mounting flange		28	40	56	71	90	125	180	
14	SAE J744								
	2-hole	●	●	●	-	-	-	-	C
	4-hole	-	-	-	-	-	-	●	D
	2+4-hole	-	-	-	●	●	●	-	F

Working port (port plate)

Port thread: Metric with profile sealing ring seal based on DIN 3852		28	40	56	71	90	125	180	
Fastening thread at the SAE working port and through drive: Metric according to DIN 13									
SAE working port A and B , top and bottom	suction port S bottom	-	●	●	●	●	●	●	02
SAE working port A and B , top and bottom	suction port S at top	-	●	●	○	○	○	○	03
SAE working port A and B , same side right ⁶⁾	suction port S bottom	●	-	-	-	-	-	-	10
SAE working port A and B , same side left ⁶⁾	suction port S bottom	-	-	-	●	○	●	-	
SAE working port A and B , same side right ⁶⁾	suction port S at top	-	-	-	○	○	○	-	13
SAE working port A and B , same side left ⁶⁾	suction port S at top	●	-	●	-	-	-	-	
Port thread: Metric with O-ring seal based on ISO 6149									
Fastening thread at the SAE working port and through drive: Metric according to DIN 13									
SAE working port A and B , top and bottom	suction port S bottom	-	●	-	-	-	●	-	22
SAE working port A and B , same side right ⁶⁾	suction port S bottom	●	-	-	-	-	-	-	30

● = Available ○ = On request - = Not available = Preferred program

4) Standard for combination pump – 1st pump: Shaft Z

5) Standard for combination pump – 1st pump: Shaft S

6) Only possible without attachment filter

01	02	03	04	05	06	07	08	09	10	11	12	13	14	15	16	17	18	19	20	21	22
A4V	G			D					/	32		-	N								

Boost pump											28	40	56	71	90	125	180			
16	Without integrated boost pump										without through drive		●	●	●	●	●	●	●	N
											with through drive		●	●	●	●	●	●	●	K
	Integrated boost pump										with and without through drive		●	●	●	●	●	●	●	F

Through drive⁷⁾											28	40	56	71	90	125	180	
17	Without through drive, only for version N and F (position 16)										●	●	●	●	●	●	●	00
	Flange SAE J744		Hub for splined shaft															
	82-2 (A)		5/8 in		9T 16/32DP ⁸⁾						●	●	●	●	●	●	●	01
			3/4 in		11T 16/32DP ⁸⁾						-	●	●	●	-	-	●	52
	101-2 (B)		7/8 in		13T 16/32DP ⁸⁾						●	●	●	●	●	●	●	02
			1 in		15T 16/32DP ⁸⁾						●	●	●	●	●	●	●	04
	127-2 (C)		1 in		15T 16/32DP ⁸⁾						-	●	-	-	-	-	-	09
	127-2 (C)		1 1/4 in		14T 12/24DP ⁸⁾						-	-	●	●	-	-	●	07
	127-2/4 (C)								-	-	-	-	●	●	-			
	152-2/4 (D)		W35		2×30×16×9g ⁹⁾						-	-	-	-	●	-	-	73
1 3/4 in			13T 8/16DP ⁸⁾						-	-	-	-	-	●	●	69		
165-4 (E)		1 3/4 in		13T 8/16DP ⁸⁾						-	-	-	-	-	-	●	72	

High-pressure relief valve				Setting range Δp_{HD}	28	40	56	71	90	125	180	
18	High-pressure relief valve, pilot operated		100 ... 420 bar	with bypass	-	-	-	●	●	●	●	1
	High-pressure relief valve direct operated, fixed setting		250 ... 420 bar	without bypass	●	●	●	-	-	-	-	3
				with bypass	●	●	●	-	-	-	-	5
			100 ... 250 bar	without bypass	●	●	●	-	-	-	-	4
				with bypass	●	●	●	-	-	-	-	6

Filtration boost circuit/external boost pressure supply											28	40	56	71	90	125	180	
19	Filtration in the boost pump suction line										●	●	●	●	●	●	●	S
	Filtration in the boost pump pressure line																	
	Ports for external boost circuit filtration (F_e and F_a)										●	●	●	●	●	●	●	D
	Attachment filter with cold start valve										-	●	●	●	●	●	●	F
	Attachment filter with cold start valve and visual contamination indicator										-	●	●	●	●	●	●	P
	Attachment filter with cold start valve and electric contamination indicator										-	●	●	●	●	●	●	B
	External boost pressure supply (version without integrated boost pump – N00, K...)										●	●	●	●	●	●	●	E

Swivel angle sensor											28	40	56	71	90	125	180	
20	Without swivel angle sensor (without code)										●	●	●	●	●	●	●	
	Electric swivel angle sensor mounted ¹⁰⁾										○	○	○	○	○	○	○	R

● = Available ○ = On request - = Not available = Preferred program

7) Specifications for version with integrated boost pump, please contact us for version without boost pump
 8) Hub for splined shaft according to ANSI B92.1a (Splined shaft in accordance with SAE J744)
 9) Hub for splined shaft according to DIN 5480
 10) The swivel angle sensor is used to detect the swivel angle and thus the displacement. For available options regarding the swivel angle detection, please contact us.

01	02	03	04	05	06	07	08	09	10	11	12	13	14	15	16	17	18	19	20	21	22	
A4V	G			D					/	32		-	N									

Connector for solenoids¹¹⁾

		28	40	56	71	90	125	180	
21	Without connector (without code), only with purely hydraulic controls	•	•	•	•	•	•	•	
	DEUTSCH connector molded, 2-pin								
	without suppressor diode	•	•	•	•	•	•	•	P
	with suppressor diode (only for EZ and DA)	•	•	•	•	•	•	•	Q

Standard/special version

22	Standard version	without code	
	Special version		-S

• = Available ◦ = On request - = Not available = Preferred program

Notice

- ▶ Note the project planning notes on page 101!
- ▶ In addition to the type code, please specify the relevant technical data when placing your order.
- ▶ Please note that not all type code combinations are available although the individual functions are marked as being available.



Hydraulic fluids

The axial piston unit is designed for operation with HLP mineral oil according to DIN 51524.

Application instructions and requirements for hydraulic fluid selection, behavior during operation as well as disposal and environmental protection should be taken from the following data sheets before the start of project planning:

- ▶ 90220: Hydraulic fluids based on mineral oils and related hydrocarbons
- ▶ 90221: Environmentally acceptable hydraulic fluids
- ▶ 90222: Fire-resistant, water-free hydraulic fluids (HFDR/HFDU)
- ▶ 90225: Limited technical data for operation with water-free and water-containing fire-resistant hydraulic fluids (HFDR, HFDU, HFAE, HFAS, HFB, HFC).

Selection of hydraulic fluid

evaluates hydraulic fluids on the basis of the Fluid Rating according to the technical data sheet 90235. Hydraulic fluids with positive evaluation in the Fluid Rating are provided in the following technical data sheet:

- ▶ 90245: Fluid Rating List for hydraulic components (pumps and motors)

Selection of hydraulic fluid shall make sure that the operating viscosity in the operating temperature range is within the optimum range (v_{opt} ; see selection diagram).

Viscosity and temperature of hydraulic fluids

	Viscosity	Shaft seal	Temperature ³⁾	Remarks
Cold start	$v_{max} \leq 1600 \text{ mm}^2/\text{s}$	NBR ²⁾	$\vartheta_{St} \geq -40 \text{ }^\circ\text{C}$	$t \leq 3 \text{ min}$, without load ($p \leq 50 \text{ bar}$), $n \leq 1000 \text{ rpm}$ Permissible temperature difference between axial piston unit and hydraulic fluid in the system maximum 25 K
		FKM	$\vartheta_{St} \geq -25 \text{ }^\circ\text{C}$	
Warm-up phase	$v = 1600 \dots 400 \text{ mm}^2/\text{s}$			$t \leq 15 \text{ min}$, $p \leq 0.7 \times p_{nom}$ and $n \leq 0.5 \times n_{nom}$
Continuous operation	$v = 400 \dots 10 \text{ mm}^2/\text{s}^{1)}$	NBR ²⁾	$\vartheta \leq +85 \text{ }^\circ\text{C}$	Measured at port T
		FKM	$\vartheta \leq +110 \text{ }^\circ\text{C}$	
	$v_{opt} = 36 \dots 16 \text{ mm}^2/\text{s}$			Optimal operating viscosity and efficiency range
Short-term operation	$v_{min} = 10 \dots 7 \text{ mm}^2/\text{s}$	NBR ²⁾	$\vartheta \leq +85 \text{ }^\circ\text{C}$	$t \leq 3 \text{ min}$, $p \leq 0.3 \times p_{nom}$, measured at port T
		FKM	$\vartheta \leq +110 \text{ }^\circ\text{C}$	

Notice

The maximum circuit temperature of +115 °C must not be exceeded at the working ports **A** and **B** complying with the permissible viscosity.

1) This corresponds, for example on the VG 46, to a temperature range of +4 °C to +85 °C (see selection diagram)

2) Special version, please contact us

3) If the temperature at extreme operating parameters cannot be adhered to, please contact us.

▼ **Selection diagram**

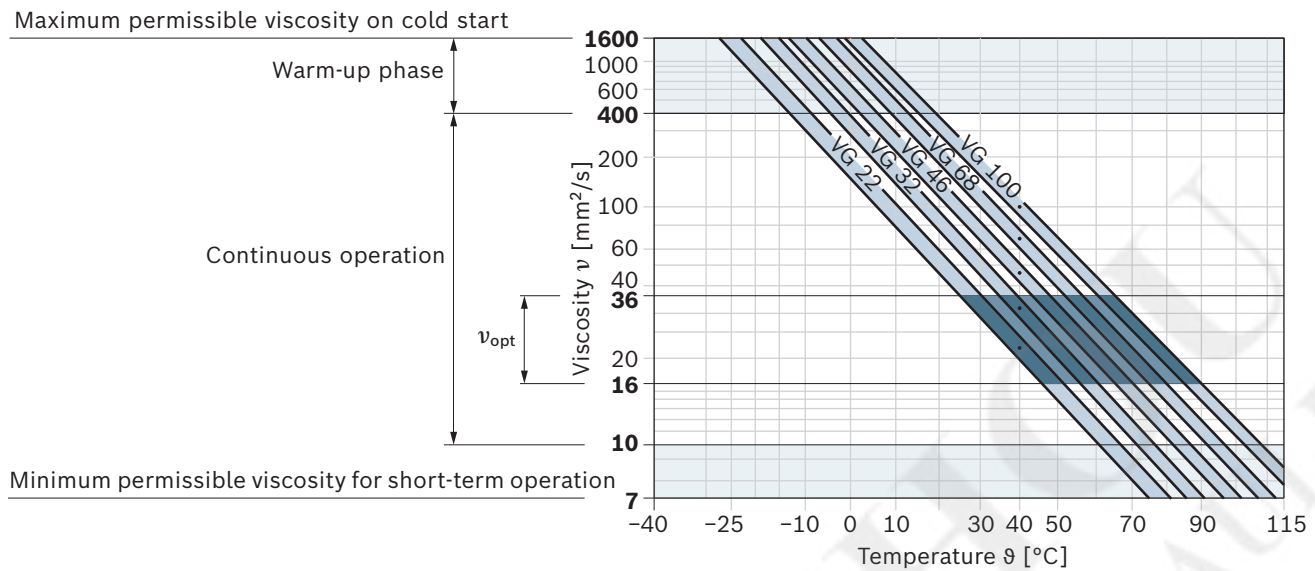

Filtration of the hydraulic fluid

Finer filtration improves the cleanliness level of the hydraulic fluid, which increases the service life of the axial piston unit.

A cleanliness level of at least 20/18/15 is to be maintained according to ISO 4406.

At a hydraulic fluid viscosity of less than 10 mm²/s (e.g. due to high temperatures during short-term operation), a cleanliness level of at least 19/17/14 according to ISO 4406 is required.

For example, a viscosity of 10 mm²/s corresponds to the following temperatures with the following media:

- ▶ HLP 32 a temperature of 73 °C
- ▶ HLP 46 a temperature of 85 °C

Working pressure range

Pressure at working port A or B		Definition
Nominal pressure p_{nom}	400 bar	The nominal pressure corresponds to the maximum design pressure.
Maximum pressure p_{max}	450 bar	The maximum pressure corresponds to the maximum working pressure within a single operating period. The sum of single operating periods must not exceed the total operating period.
Maximum single operating period	10 s	
Total operating period	300 h	
Minimum pressure (low-pressure side)	10 bar above case pressure	Minimum pressure on the low-pressure side (A or B) required to prevent damage to the axial piston unit. Boost pressure setting must be higher depending on system.
Rate of pressure change $R_{A\ max}$	9000 bar/s	Maximum permissible speed of pressure build-up and reduction during a pressure change across the entire pressure range.
Boost pump		
Nominal pressure $p_{Sp\ nom}$	25 bar	
Maximum pressure $p_{Sp\ max}$	40 bar	
Pressure at suction port S (inlet)		
Continuous $p_{S\ min}$	≥ 0.8 bar absolute	$v \leq 30$ mm ² /s
Short-term, at a cold start	≥ 0.5 bar absolute	$t < 3$ min
Maximum pressure $p_{S\ max}$	≤ 5 bar absolute	
Control pressure		
Minimum control pressure $p_{St\ min}$ at $n = 2000$ rpm		Required control pressure p_{St} , to ensure the function of the control. The required control pressure is dependent on rotational speed, working pressure and the spring assembly of the stroking piston.
Controls EP, HD, HW	20 bar above case pressure	
Controls DA, DG, EZ, ET	25 bar above case pressure	
Case pressure at port T		
Continuous differential pressure $\Delta p_{T\ cont}$	2 bar	Maximum, averaged differential pressure at the shaft seal (case to ambient pressure)
Maximum differential pressure $\Delta p_{T\ max}$	see diagram on page 9	Permissible differential pressure at the shaft seal (case to ambient pressure)
Pressure peaks $p_{T\ peak}$	10 bar	$t < 0.1$ s, maximum 1000 pressure peaks permissible

▼ **Maximum pressure p_{max} up to 450 bar and total operating period**

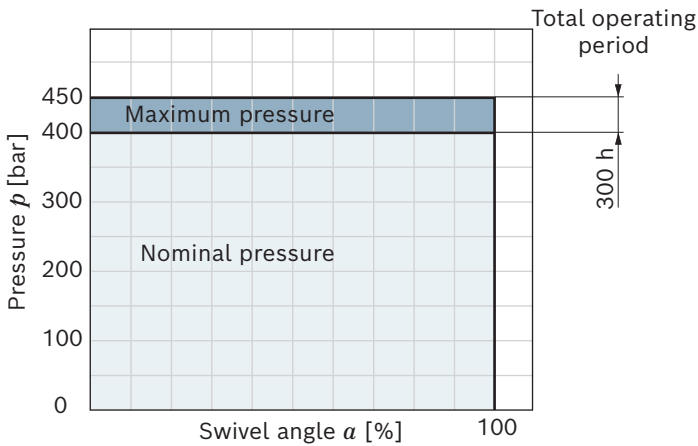

▼ **Pressure definition**

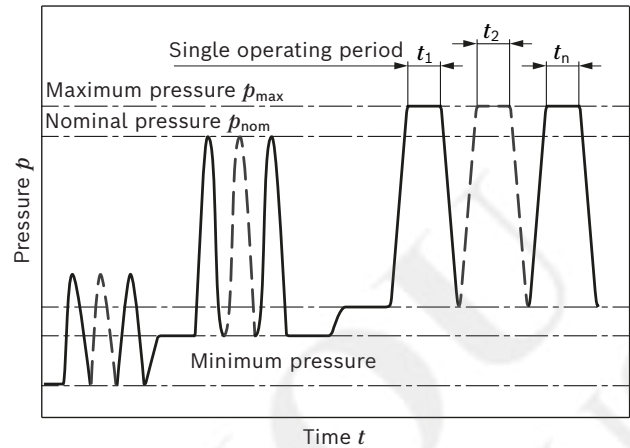

▼ **Rate of pressure change R_{Amax}**

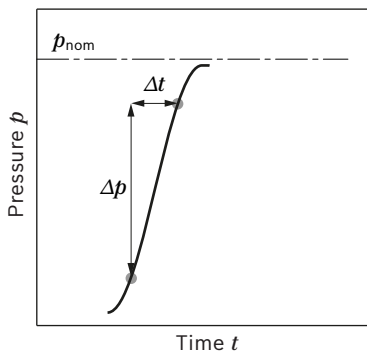

Notice

- ▶ Working pressure range applies when using hydraulic fluids based on mineral oils. Please contact us for values for other hydraulic fluids.
- ▶ In addition to the hydraulic fluid and the temperature, the service life of the shaft seal is influenced by the rotational speed of the axial piston unit and the case pressure.
- ▶ The service life of the shaft seal decreases with increasing frequency of pressure peaks and increasing mean differential pressure.
- ▶ The case pressure must be greater than the external pressure (ambient pressure) at the shaft seal.

Total operating period = $t_1 + t_2 + \dots + t_n$

▼ **Maximum differential pressure at the shaft seal**

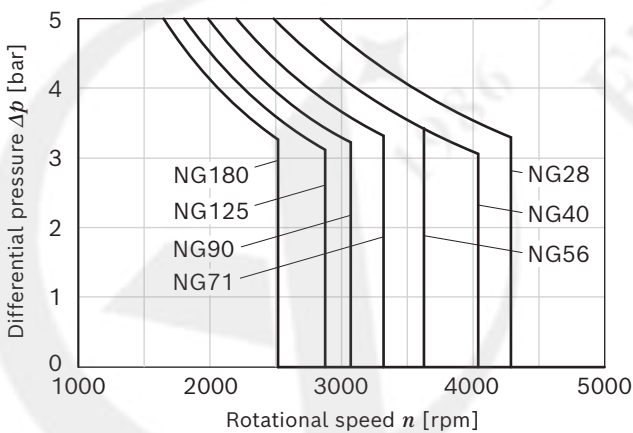

Technical data

Size		NG	28	40	56	71	90	125	180		
Geometric displacement, per revolution	variable pump	$V_{g \max}$	cm ³	28	40	56	71	90	125	180	
	boost pump (at $p = 20$ bar)	$V_{g Sp}$	cm ³	6.1	8.6	11.6	19.6	19.6	28.3	39.8	
Rotational speed ¹⁾	maximum at $V_{g \max}$	n_{nom}	rpm	4250	4000	3600	3300	3050	2850	2500	
	limited maximum ²⁾	n_{max1}	rpm	4500	4200	3900	3600	3300	3250	2900	
	intermittent maximum ³⁾	n_{max2}	rpm	5000	5000	4500	4100	3800	3450	3000	
	minimum	n_{min}	rpm	500	500	500	500	500	500	500	
Flow	at n_{nom} and $V_{g \max}$	q_v	l/min	119	160	202	234	275	356	450	
Power ⁴⁾	at n_{nom} , $V_{g \max}$ and $\Delta p = 400$ bar	P	kW	79	107	134	156	183	238	300	
Torque ⁴⁾	with $V_{g \max}$ and	$\Delta p = 400$ bar	M	Nm	178	255	357	452	573	796	1146
		$\Delta p = 100$ bar	M	Nm	45	64	89	113	143	199	286
Rotary stiffness of drive shaft	S	c	kNm/rad	31.4	69	80.8	98.8	158.1	218.3	244.5	
	T	c	kNm/rad	–	–	95	120.9	–	252.1	318.4	
	A	c	kNm/rad	–	79.6	95.8	142.4	176.8	256.5	–	
	Z	c	kNm/rad	32.8	67.5	78.8	122.8	137	223.7	319.6	
	U	c	kNm/rad	–	50.8	–	–	107.6	–	–	
Moment of inertia of the rotary group		J_{TW}	kgm ²	0.0022	0.0038	0.0066	0.0097	0.0149	0.0232	0.0444	
Maximum angular acceleration ⁵⁾		α	rad/s ²	38000	30000	24000	21000	18000	14000	11000	
Case volume		V	l	0.9	1.1	1.5	1.3	1.5	2.1	3.1	
Weight (without through drive) approx. ⁶⁾		m	kg	29	31	38	50	60	80	101	

Notice

- ▶ Theoretical values, without efficiency and tolerances; values rounded
- ▶ Operation above the maximum values or below the minimum values may result in a loss of function, a reduced service life or in the destruction of the axial piston unit. recommends testing the loads by means of experiment or calculation /simulation and comparison with the permissible values.

Determination of the operating characteristics

Flow	$q_v = \frac{V_g \times n \times \eta_v}{1000}$	[l/min]
Torque	$M = \frac{V_g \times \Delta p}{20 \times \pi \times \eta_{hm}}$	[Nm]
Power	$P = \frac{2 \pi \times M \times n}{60000} = \frac{q_v \times \Delta p}{600 \times \eta_t}$	[kW]

Key

V_g	Displacement per revolution [cm ³]
Δp	Differential pressure [bar]
n	Rotational speed [rpm]
η_v	Volumetric efficiency
η_{hm}	Hydraulic-mechanical efficiency
η_t	Total efficiency ($\eta_t = \eta_v \times \eta_{hm}$)

1) The values are applicable:

- for the optimum viscosity range from $v_{opt} = 36$ to 16 mm²/s
- for hydraulic fluid based on mineral oils (for HF hydraulic fluids, observe the technical data in 90225)

2) Valid at half corner power (e.g. at $V_{g \max}$ and $p_N/2$)

3) Valid at $\Delta p = 70$ to 150 bar or $\Delta p < 300$ bar and $t < 0.1$ s

4) Without boost pump

5) The data are valid for values between the minimum required and maximum permissible rotational speed.

Valid for external excitation (e.g. diesel engine 2 to 8 times rotary frequency; cardan shaft twice the rotary frequency).

The limit value is only valid for a single pump.

The load capacity of the connection parts must be considered.

6) Weight may vary by equipment.

Permissible radial and axial loading of the drive shaft

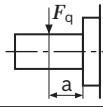
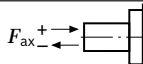

▼ Splined shaft DIN 5480

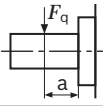
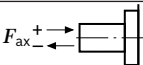
Size	NG		28	40	40	56	56	71	71	
Drive shaft			W25	W30	W35	W30	W35	W35	W40	
Maximum radial force at distance a (to the shaft collar)		$F_{q \max}$	N	3030	3608	3092	5051	4329	5489	4803
		a	mm	17.5	17.5	20	17.5	20	20	22.5
Maximum axial force		$+ F_{ax \max}$	N	1557	2120	2120	2910	2910	4242	4242
		$- F_{ax \max}$	N	417	880	880	1490	1490	2758	2758

Size	NG		90	90	125	125	180			
Drive shaft			W35	W45	W40	W45	W50			
Maximum radial force at distance a (to the shaft collar)		$F_{q \max}$	N	6957	5411	8455	7516	9740		
		a	mm	20	25	22.5	25	27.5		
Maximum axial force		$+ F_{ax \max}$	N	4330	4330	6053	6053	7500		
		$- F_{ax \max}$	N	2670	2670	3547	3547	4500		

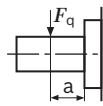
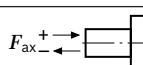
▼ Splined shaft ANSI B92.1a

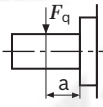
Size	NG		28	40	40	56	56	71	71	
Drive shaft		in	1	1	1 1/4	1 1/4	1 3/8	1 1/4	1 3/8	
Maximum radial force at distance a (to the shaft collar)		$F_{q \max}$	N	2983	4261	3409	4772	4338	6050	5500
		a	mm	19	19	24	24	24	24	24
Maximum axial force		$+ F_{ax \max}$	N	1557	2120	2120	2910	2910	4242	4242
		$- F_{ax \max}$	N	417	880	880	1490	1490	2758	2758

Size	NG		90	90	125	125	180	180	
Drive shaft		in	1 1/4	1 3/4	1 3/4	2	1 3/4	2 1/4	
Maximum radial force at distance a (to the shaft collar)		$F_{q \max}$	N	7670	5478	7609	6658	10956	8522
		a	mm	24	33.5	33.5	40	33.5	40
Maximum axial force		$+ F_{ax \max}$	N	4330	4330	6053	6053	7500	7500
		$- F_{ax \max}$	N	2670	2670	3547	3547	4500	4500

Notice

- ▶ The axial and radial loading generally influence the bearing service life.
- ▶ Special requirements apply in the case of belt drive and cardan shaft. Please contact us.

Permissible input and through-drive torques

Size	NG		28	40	56	71	90	125	180	
Torque at $V_{g \max}$ and $\Delta p = 400 \text{ bar}^1)$	M	Nm	178	255	357	452	573	796	1146	
Max. input torque on drive shaft ²⁾										
DIN 5480	Z	$M_{E \max}$	Nm	352	522	522	912	912	1460	3140
				W25	W30	W30	W35	W35	W40	W50
	A	$M_{E \max}$	Nm	–	912	912	1460	2190	2190	–
					W35	W35	W40	W45	W45	
ANSI B92.1a (SAE J744)	S	$M_{E \max}$	Nm	314	602	602	602	1640	1640	1640
			in	1	1 1/4	1 1/4	1 1/4	1 3/4	1 3/4	1 3/4
	T	$M_{E \max}$	Nm	–	–	970	970	–	2670	4070
			in	–	–	1 3/8	1 3/8	–	2	2 1/4
	U ³⁾	$M_{E \max}$	Nm	–	314	–	–	602	–	–
			in	–	1	–	–	1 1/4	–	–
Maximum through-drive torque ⁴⁾	$M_{D \max}$	Nm	231	314	521	660	822	1110	1760	

▼ **Distribution of torques**

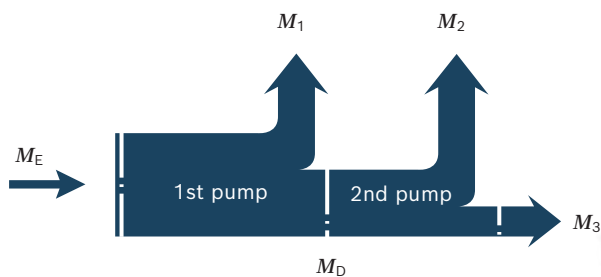

Torque at 1st pump	M_1
Torque at 2nd pump	M_2
Torque at 3rd Pump	M_3
Input torque	$M_E = M_1 + M_2 + M_3$
	$M_E < M_{E \max}$
Through-drive torque	$M_D = M_2 + M_3$
	$M_D < M_{D \max}$

- 1) Efficiency not considered
- 2) For drive shafts free of radial force
- 3) Shaft "U" is only permissible as a drive shaft for the 2nd pump in a combination pump of the same size.
- 4) Note maximum input torque for shaft S!

NV – Version without control module

The mounting surface for the control module is machined and sealed with the standard seal for control modules and a cover plate. This version is ready for retrofitting to control modules (HD, HW, EP, EZ). When used directly for "DA" control and in combinations with "DA" control, the appropriate adjustments must be made to the spring assembly of the adjustment cylinder and control plate.

▼ Circuit diagram, standard version¹⁾

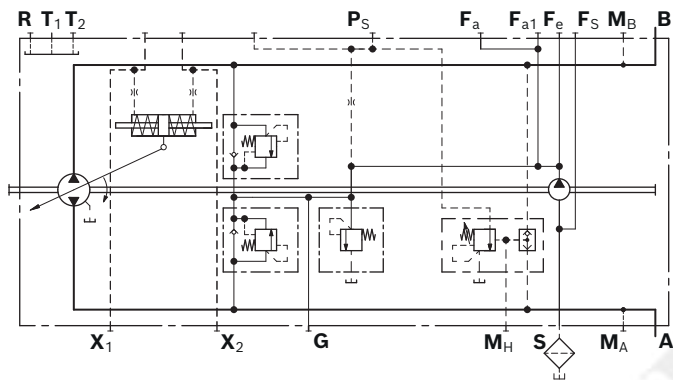

HD – Proportional control, hydraulic, pilot-pressure related

The output flow of the pump is infinitely variable between 0 and 100%, proportional to the difference in pilot pressure applied to the two pilot signal ports (Y_1 and Y_2).

The pilot signal, coming from an external source, is a pressure signal. Flow is negligible, as the pilot signal acts only on the control spool of the control valve.

This control spool then directs control oil into and out of the stroking cylinder to adjust pump displacement as required.

A feedback lever connected to the stroking piston maintains the pump flow for any given pilot signal within the control range.

If the pump is also equipped with a DA control valve (see page 18), automotive operation is possible for travel drives.

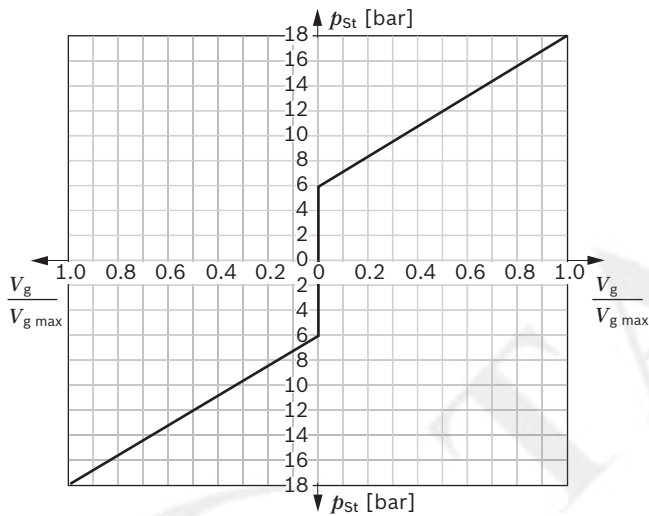

Size	28 ... 180		
Start of control (V_{g0})	p_{St}	bar	6
End of control (V_{gmax})	p_{St}	bar	18

Key

V_g	Displacement
V_{g0}	Displacement in neutral position
V_{gmax}	Maximum displacement
p_{St}	Pilot signal at port Y_1, Y_2

Notice

In the neutral position, the HD control module must be unloaded to reservoir via the external pilot control device.

▼ Circuit diagram, standard version¹⁾

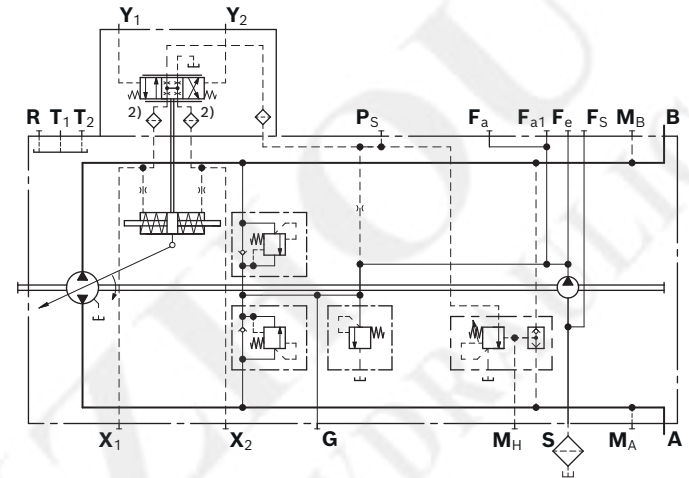

▼ Circuit diagram, version with DA control valve¹⁾

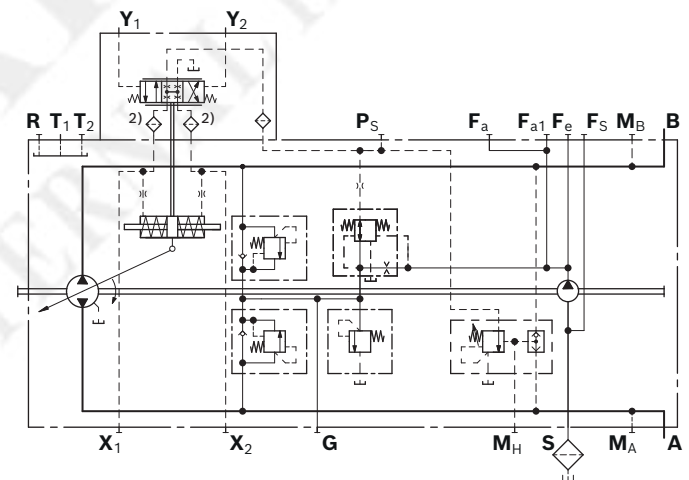

1) Size 28 without port F_{a1} and F_S

2) Only sizes 28 to 71 are designed with inlet filtration in X_1/X_2

Correlation of direction of rotation, control and flow direction									
Direction of rotation		Clockwise				Counter-clockwise			
Size		28 ... 56		71 ... 180		28 ... 56		71 ... 180	
Pilot signal		Y ₁	Y ₂	Y ₁	Y ₂	Y ₁	Y ₂	Y ₁	Y ₂
Control pressure		X ₁	X ₂	X ₁	X ₂	X ₁	X ₂	X ₁	X ₂
Port plate 02 and 10	Flow direction	A to B	B to A	B to A	A to B	B to A	A to B	A to B	B to A
	Working pressure	M _B	M _A	M _A	M _B	M _A	M _B	M _B	M _A
Port plate 03 and 13	Flow direction	B to A	A to B	A to B	B to A	A to B	B to A	B to A	A to B
	Working pressure	M _A	M _B	M _B	M _A	M _B	M _A	M _A	M _B

▼ Position of ports (example)

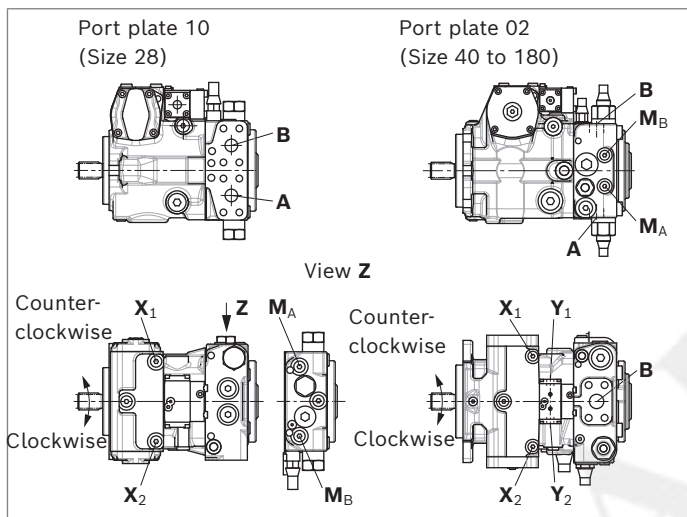

HW – Proportional control, hydraulic, mechanical servo

The output flow of the pump is infinitely variable between 0 and 100%, proportional to the swivel angle of the control lever.

A feedback lever connected to the stroking piston maintains the pump flow for any given position of the control lever. If the pump is also equipped with a DA control valve (see page 18), automotive operation is possible for travel drives.

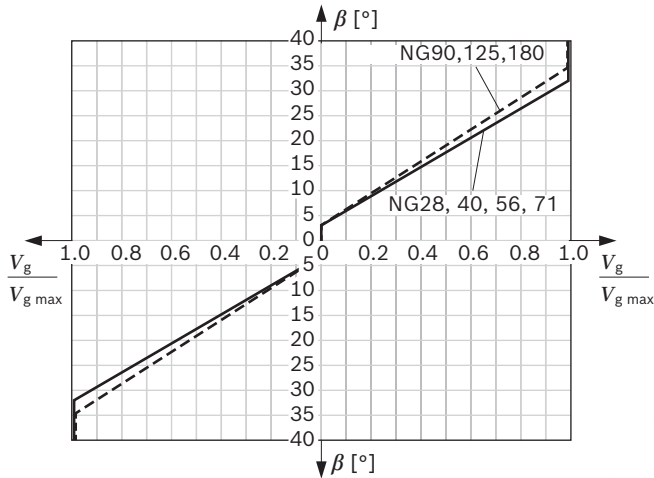

Size	28 ... 71	90 ... 180
Start of control (V_{g0})	β $\pm 3^\circ$	$\pm 3^\circ$
End of control (V_{gmax})	β $\pm 32^\circ$	$\pm 34.5^\circ$
Rotational limiter control lever (internal)	β $\pm 38^\circ$	$\pm 38^\circ$

The maximum required torque at the control lever is 170 Ncm. To prevent damage to the HW control module, a positive mechanical stop of $36.5^\circ \pm 1$ must be provided for the HW control lever on the customer side.

Key

V_g	Displacement
V_{g0}	Displacement in neutral position
V_{gmax}	Maximum displacement
β	Swivel angle at the control lever

Notice

- ▶ Spring-centering enables the pump, depending on pressure and rotational speed, to move automatically to the neutral position ($V_g = 0$) as soon as there is no longer any torque on the control lever of the HW control module.
- ▶ As standard delivery, the control lever is oriented toward the through drive (see dimensions).
- ▶ If necessary, the position of the lever can be changed. The procedure is defined in the instruction manual.
- ▶ The position of the control lever can deviate from the installation drawing.

Option: Neutral position switch

The switch contact in the neutral position switch is closed when the control lever on the HW control module is in its neutral position. The switch opens when the control lever is moved out of the central position in either direction. Thus, the neutral position switch provides a monitoring function for drive units that require the control lever at the HW control module to be in the neutral position during certain operating conditions (e.g. starting diesel engine).

Technical data

Load capacity	20 A (continuous), without switching operations
Switching capacity	15 A / 32 V (resistive load) 4 A / 32 V (inductive load)
Connector version	DEUTSCH DT04-2P-EP04 (mating connector, see page 95)

▼ Circuit diagram, standard version¹⁾

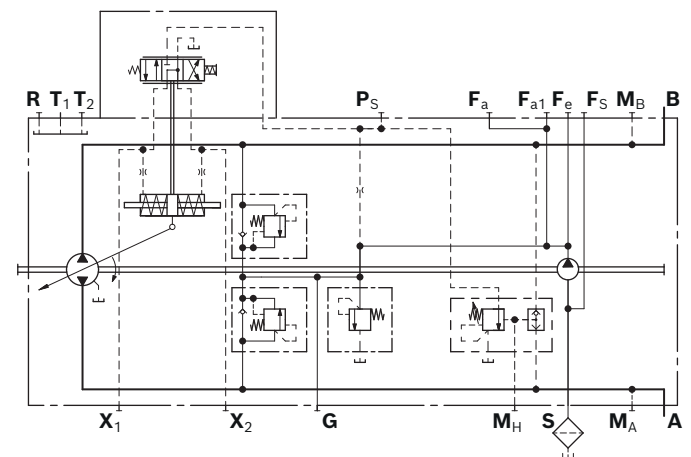

1) Size 28 without port F_{a1} and F_s

Circuit diagram, version with DA control valve and neutral position switch¹⁾

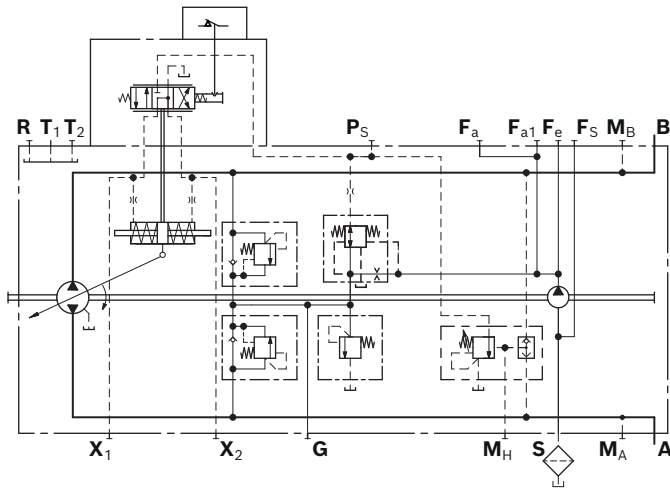

Correlation of direction of rotation, control and flow direction

Direction of rotation		Clockwise				Counter-clockwise			
Size		28 ... 56		71 ... 180		28 ... 56		71 ... 180	
Lever direction ²⁾		ccw	cw	ccw	cw	ccw	cw	ccw	cw
Control pressure		X₂	X₁	X₂	X₁	X₂	X₁	X₂	X₁
Port plate 02 and 10	Flow direction	B to A	A to B	A to B	B to A	A to B	B to A	B to A	A to B
	Working pressure	M_A	M_B	M_B	M_A	M_B	M_A	M_A	M_B
Port plate 03 and 13	Flow direction	A to B	B to A	B to A	A to B	B to A	A to B	A to B	B to A
	Working pressure	M_B	M_A	M_A	M_B	M_A	M_B	M_B	M_A

▼ **Position of ports (example)**

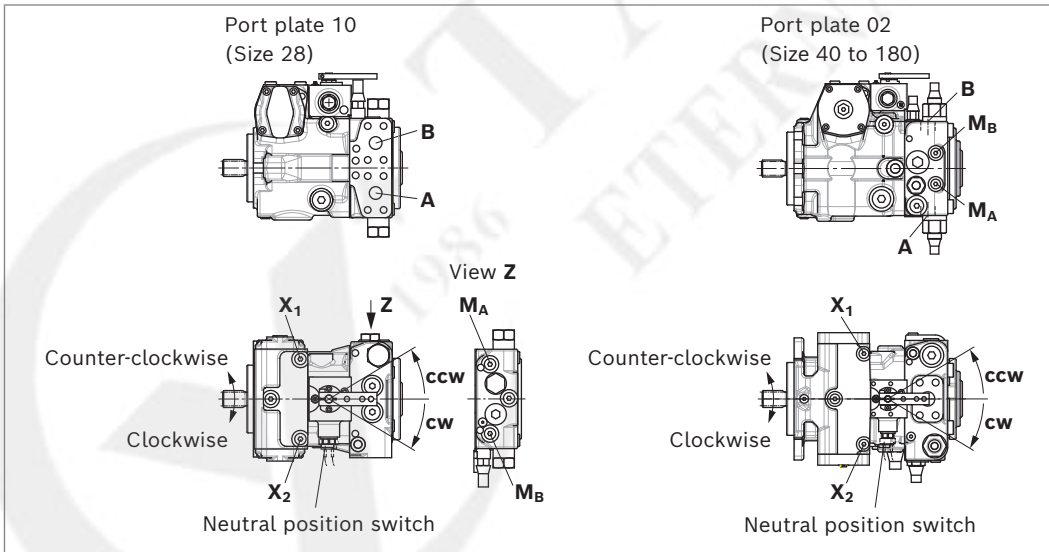

1) Size 28 without port **F_{a1}** and **F_s**

2) ccw = counter-clockwise,
cw = clockwise

DA – Automatic control, speed related

The DA closed loop control is an engine speed-dependent system for travel drives. The built-in DA control valve generates a pilot pressure that is proportional to pump drive speed (of the motor). This pilot pressure is directed to the stroking cylinder of the pump by an electromagnetically actuated 4/3-way directional valve. The pump displacement is infinitely variable in each flow direction and is influenced by both pump drive speed and system pressure. The flow direction (i.e. machine moving forward or backward) is determined by either solenoid **a** or **b** being activated.

Increasing the pump drive speed generates a higher pilot pressure from the DA control valve, with a subsequent increase in pump flow.

Depending on the selected operating characteristics of the pump, increasing the system pressure (i.e. machine load) causes the pump to swivel back towards a smaller displacement. An overload protection for the engine (against stalling) is achieved by combining this pressure-dependent reduction in pump stroke with a reduction in pilot pressure as the engine speed drops. Any additional power requirement, e.g. for hydraulic functions from attachments, could cause the engine rotational speed to drop further. This will cause a further reduction in pilot pressure and thus of the pump displacement. Automatic power distribution and full exploitation of the available power are achieved in this way, both for the travel drive and for the implement hydraulics, with priority given to the implement hydraulics.

Various override options are available for DA control function to allow controlled operation of the implement hydraulics with high rotational speeds at reduced travel speed.

The DA control valve can also be used in pumps with EP, DG, HW and HD control modules to protect the combustion engine against overload.

Notice

DA closed loop control is only suitable for certain types of travel drive systems and requires review of the motor and vehicle parameters to ensure that the pump is used correctly and that machine operation is safe and efficient.

Technical data, switching solenoid	DA1	DA2
Voltage	12 V (±20%)	24 V (±20%)
Neutral position $V_g = 0$	de-energized	de-energized
Position $V_{g \max}$	current switched on	current switched on
Nominal resistance (at 20 °C)	5.5 Ω	21.7 Ω
Nominal power	26.2 W	26.5 W
Minimum required active current	1.32 A	0.67 A
Duty cycle	100%	100%
Type of protection: see connector version page 95		

▼ Position of ports (example)

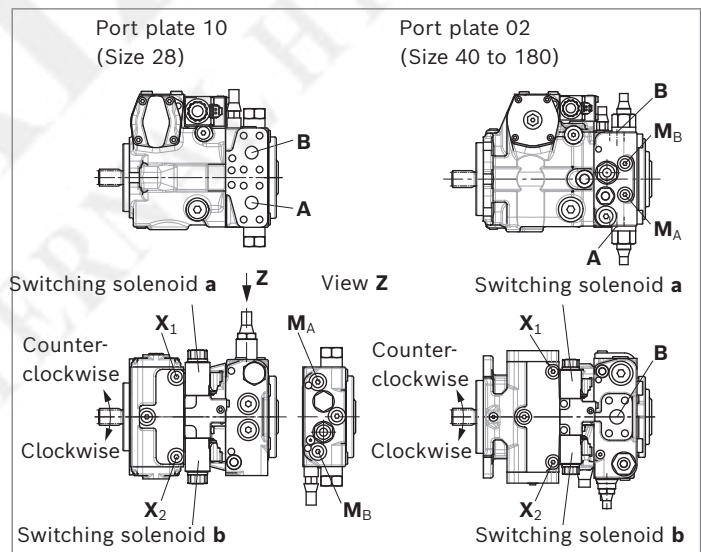

Correlation of direction of rotation, control and flow direction

Direction of rotation	Clockwise				Counter-clockwise				
	28 ... 56		71 ... 180		28 ... 56		71 ... 180		
Actuation of switching solenoid	a	b	a	b	a	b	a	b	
Control pressure	X₂	X₁	X₂	X₁	X₂	X₁	X₂	X₁	
Port plate 02 and 10	Flow direction	B to A	A to B	A to B	B to A	A to B	B to A	B to A	A to B
	Working pressure	M_A	M_B	M_B	M_A	M_B	M_A	M_A	M_B
Port plate 03 and 13	Flow direction	A to B	B to A	B to A	A to B	B to A	A to B	A to B	B to A
	Working pressure	M_B	M_A	M_A	M_B	M_A	M_B	M_B	M_A

DA..2 – DA control valve, fixed setting

Pilot pressure is generated in relation to drive speed.

▼ **Circuit diagram DA control valve, fixed setting, DA1D2/DA2D2¹⁾**

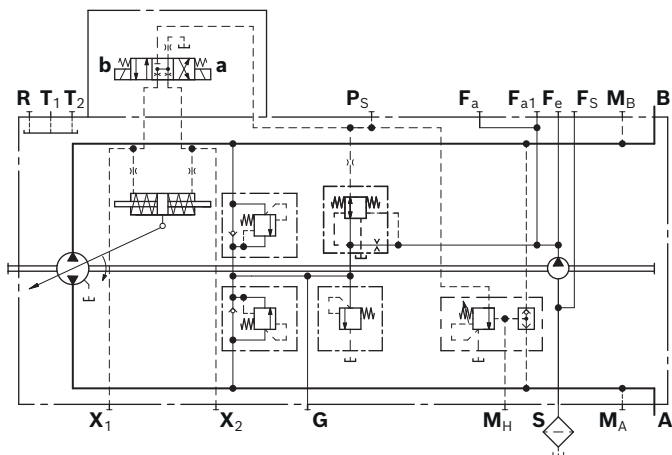

DA..3 – DA control valve, mechanically adjustable with position lever

Pilot pressure is generated in relation to drive speed.

Any reduction of pilot pressure possible, independently of drive speed, through mechanical actuation of the position lever (inch function).

The maximum permissible actuation torque at the position lever is $M_{max} = 4 \text{ Nm}$.

In the standard version, the position lever is configured for control module, see dimensions.

The maximum angle of rotation is 70° .

DA..3R

Direction of actuation of the position lever: clockwise

DA..3L

Direction of actuation of the position lever: counter-clockwise

▼ **Circuit diagram DA1D3/DA2D3¹⁾**

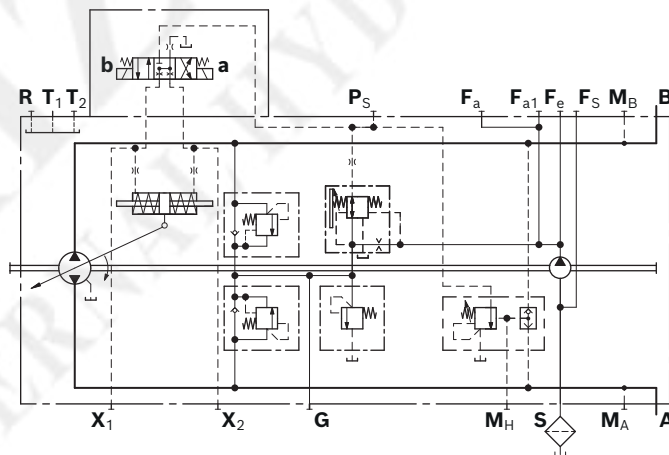

1) Size 28 without port F_{a1} and F_S

DA..7 – DA control valve, fixed setting, ports for pilot control device as inch valve

Any reduction of the pilot pressure possible, independent of the drive speed is achieved by the mechanical actuation of the pilot control device.

The pilot control device is installed separately from the pump (for example in the driver's cabin) and connected to the pump by two hydraulic control lines via ports **P_S** and **Y**. A suitable pilot control device must be ordered separately and is not included in the scope of delivery.

Notice: Rotary inch valves, see page 96.

▼ **Circuit diagram DA1D7/DA2D7¹⁾**

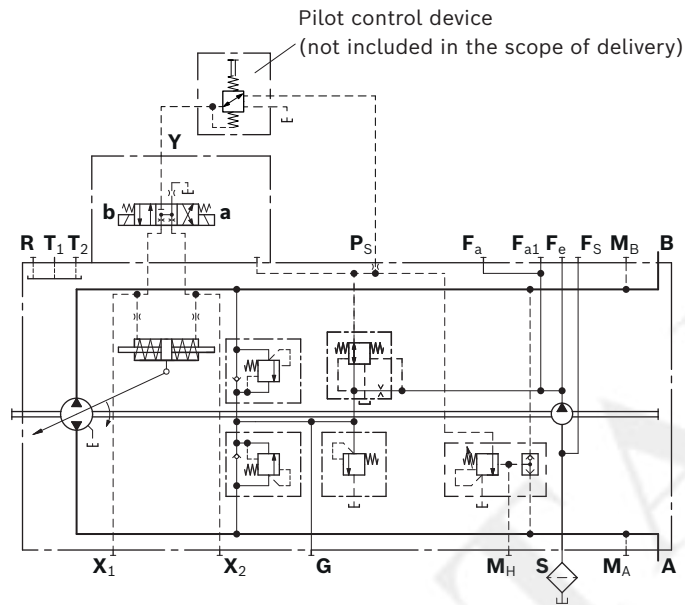

DA..8 – DA control valve, fixed setting and hydraulic inch valve mounted

Only for pumps with DA control module

- ▶ Version with throttle valve size 28, 40, 56, 71
 - ▶ Version with pressure reducing valve size 90, 125, 180
- Permits reduction of the pilot pressure, independently of the drive speed, hydraulically controlled (port **Z**).

The hydraulic inch valve at port **Z** is controlled with mineral oil-based hydraulic fluid.

Maximum permissible pilot pressure at port **Z**: 80 bar

▼ **Circuit diagram DA1D8/DA2D8 with throttle valve¹⁾**

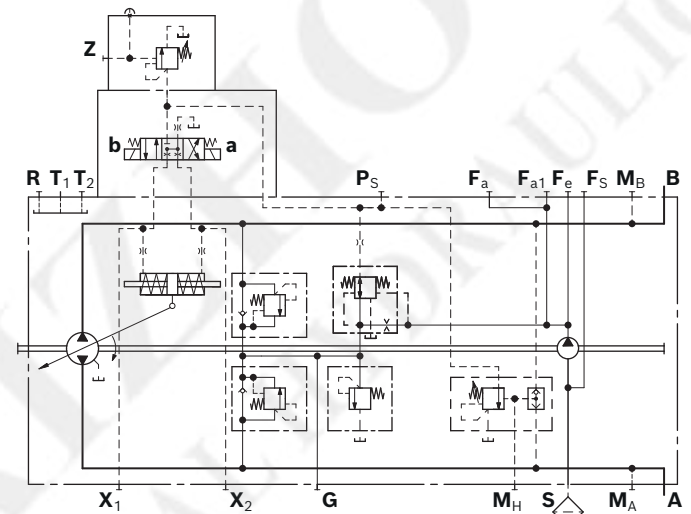

▼ **Circuit diagram DA1D8/DA2D8 with pressure reducing valve¹⁾**

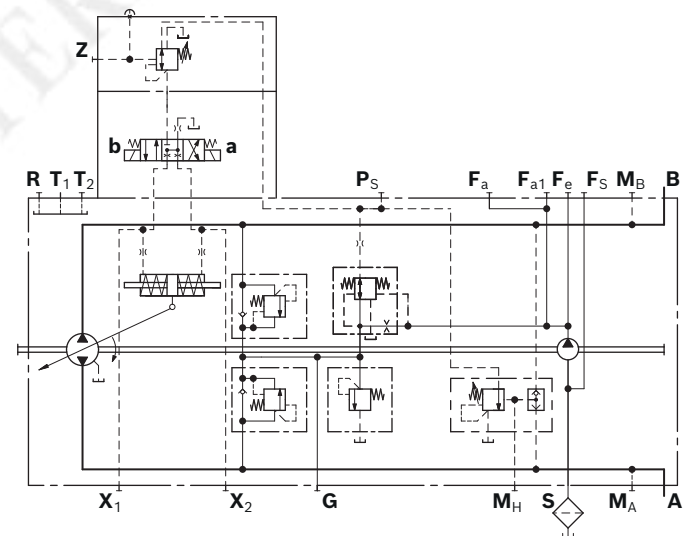

DG – Hydraulic control, direct operated

With the direct operated hydraulic control (DG), the output flow of the pump is controlled by a hydraulic control pressure, applied directly to the stroking piston through either port **X₁** or **X₂**.

Flow direction is determined by which control pressure port is pressurized.

Pump displacement is infinitely variable and proportional to the applied control pressure, but is also influenced by system pressure and pump drive speed.

In order to use the optional built-in pressure cut-off, port **P_S** must be used for the selected control module as source of the control pressure **X₁** and **X₂** generated on the customer side.

See page 86 for a functional description of the pressure cut-off.

Maximum permissible control pressure: 40 bar

Use of the DG control requires a review of the engine and vehicle parameters to ensure that the pump is set up correctly.

If the pump is also equipped with a DA control valve (see page 18), automotive operation is possible for travel drives.

▼ Circuit diagram, standard version¹⁾

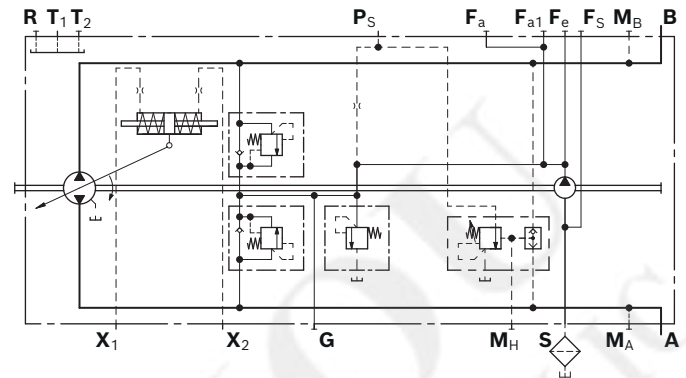

▼ Circuit diagram, version with DA control valve¹⁾

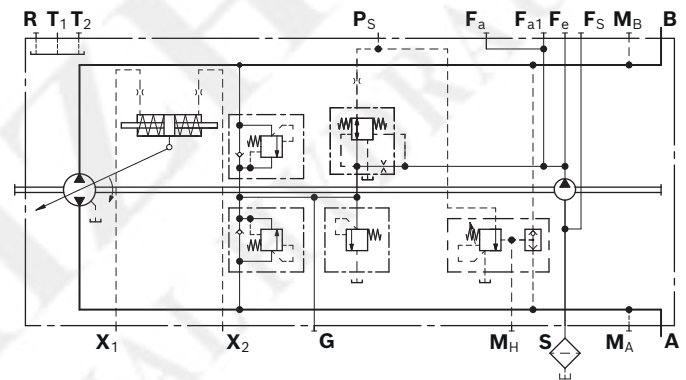

Correlation of direction of rotation, control and flow direction

Direction of rotation		Clockwise				Counter-clockwise			
Size		28 ... 56		71 ... 180		28 ... 56		71 ... 180	
Control pressure		X₁	X₂	X₁	X₂	X₁	X₂	X₁	X₂
Port plate 02 and 10	Flow direction	A to B	B to A	B to A	A to B	B to A	A to B	A to B	B to A
	Working pressure	M_B	M_A	M_A	M_B	M_A	M_B	M_B	M_A
Port plate 03 and 13	Flow direction	B to A	A to B	A to B	B to A	A to B	B to A	B to A	A to B
	Working pressure	M_A	M_B	M_B	M_A	M_B	M_A	M_A	M_B

1) Size 28 without port **F_{a1}** and **F_s**

EP – Proportional control, electric

The output flow of the pump is infinitely variable between 0 and 100%, proportional to the electrical current supplied to solenoid **a** or **b**.

The electrical energy is converted into a force acting on the control spool. This control spool then directs control oil into and out of the stroking cylinder to adjust pump displacement as required.

A feedback lever connected to the stroking piston maintains the pump flow for any given current within the control range.

If the pump is also equipped with a DA control valve (see page 18), automotive operation is possible for travel drives.

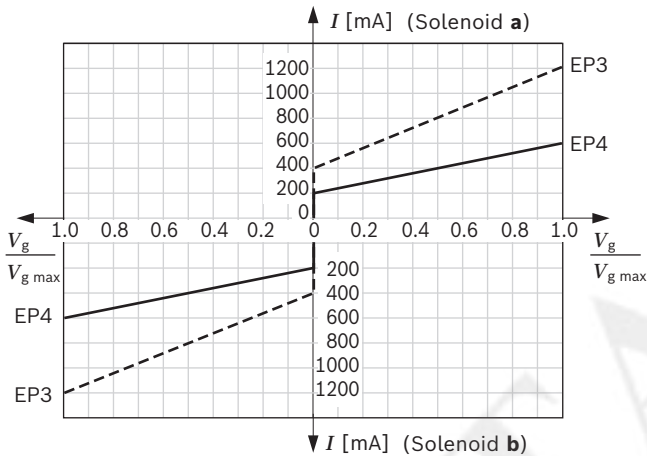

Notice

The proportional solenoids do not have manual override. Proportional solenoids with manual override and spring return are available on request.

Technical data, proportional solenoid	EP3	EP4
Voltage	12 V ($\pm 20\%$)	24 V ($\pm 20\%$)
Control current		
Start of control at $V_g = 0$	400 mA	200 mA
End of control at $V_{g \max}$	1200 mA	600 mA
Current limit	1.54 A	0.77 A
Nominal resistance (at 20 °C)	5.5 Ω	22.7 Ω
Dither		
Frequency	100 Hz	100 Hz
Minimum oscillation range ¹⁾	240 mA	120 mA
Duty cycle	100%	100%
Type of protection: see connector version page 95		

Various BODAS controllers with application software and amplifiers are available for controlling the proportional solenoids.

▼ Circuit diagram, standard version²⁾

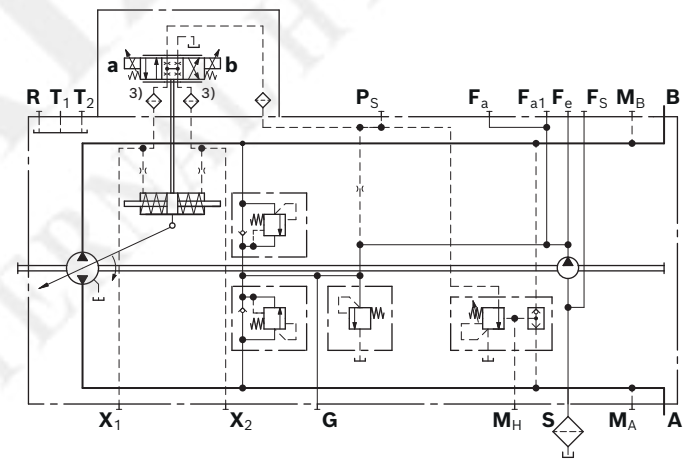

▼ Circuit diagram, version with DA control valve²⁾

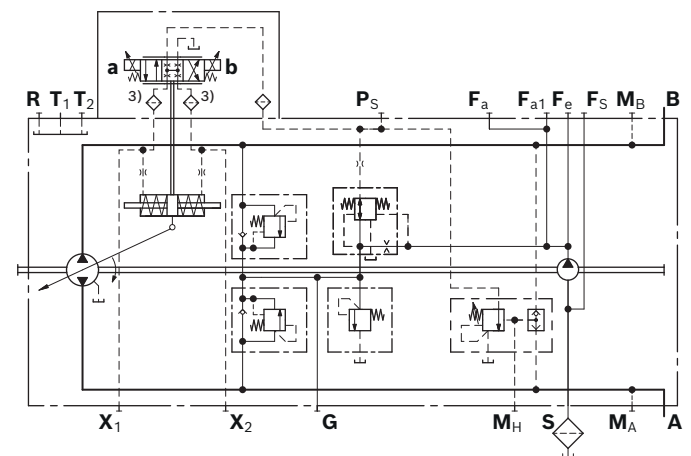

1) Minimum required oscillation range of the control current ΔI_{p-p} (peak to peak) within the respective control range (start of control to end of control)

2) Size 28 without port F_{a1} and F_S

3) Only sizes 28 to 71 are designed with inlet filtration in X_1/X_2

Correlation of direction of rotation, control and flow direction									
Direction of rotation		Clockwise				Counter-clockwise			
Size ¹⁾		28 ... 56		71 ... 180		28 ... 56		71 ... 180	
Actuation of proportional solenoid		a	b	a	b	a	b	a	b
Control pressure		X ₁	X ₂	X ₁	X ₂	X ₁	X ₂	X ₁	X ₂
Port plate 02 and 10	Flow direction	A to B	B to A	B to A	A to B	B to A	A to B	A to B	B to A
	Working pressure	M _B	M _A	M _A	M _B	M _A	M _B	M _B	M _A
Port plate 03 and 13	Flow direction	B to A	A to B	A to B	B to A	A to B	B to A	B to A	A to B
	Working pressure	M _A	M _B	M _B	M _A	M _B	M _A	M _A	M _B

▼ Position of ports (example)

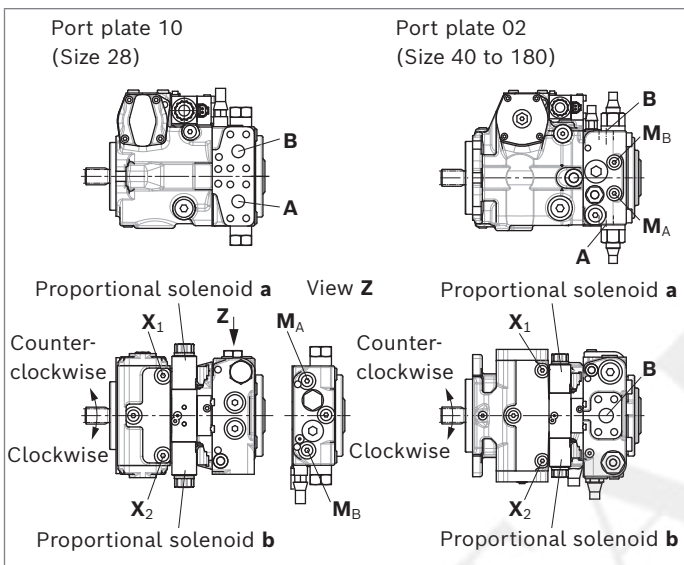

¹⁾ Available port plates per size, see type code position 15

EZ – Two-point control, electric

By actuating either switching solenoid **a** or **b**, internal control pressure is applied directly to the stroking piston and the pump swivels to maximum displacement. The EZ control enables pump flow to be switched between $V_g = 0$ and $V_g \max$. Flow direction is determined by which solenoid is energized.

Technical data, switching solenoid	EZ1	EZ2
Voltage	12 V ($\pm 20\%$)	24 V ($\pm 20\%$)
Neutral position $V_g = 0$	de-energized	de-energized
Position $V_g \max$	current switched on	current switched on
Nominal resistance (at 20 °C)	5.5 Ω	21.7 Ω
Nominal power	26.2 W	26.5 W
Minimum required active current	1.32 A	0.67 A
Duty cycle	100%	100%
Type of protection: see connector version page 95		

▼ Circuit diagram, standard version¹⁾

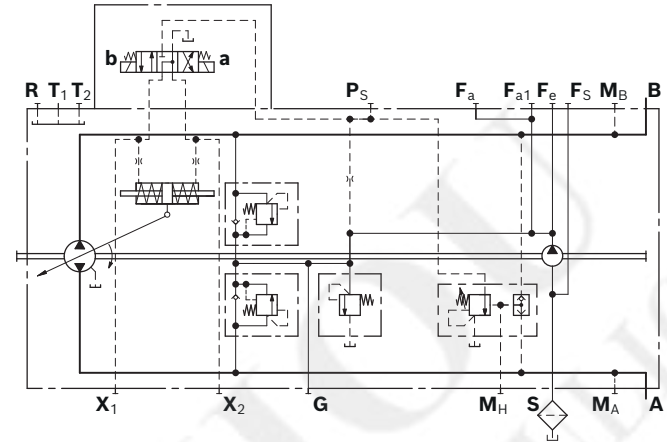

Correlation of direction of rotation, control and flow direction

Direction of rotation		Clockwise				Counter-clockwise			
		Size 28 ... 56		Size 71 ... 180		Size 28 ... 56		Size 71 ... 180	
Actuation of switching solenoid		a	b	a	b	a	b	a	b
Control pressure		X₂	X₁	X₂	X₁	X₂	X₁	X₂	X₁
Port plate 02 and 10	Flow direction	B to A	A to B	A to B	B to A	A to B	B to A	B to A	A to B
	Working pressure	M_A	M_B	M_B	M_A	M_B	M_A	M_A	M_B
Port plate 03 and 13	Flow direction	A to B	B to A	B to A	A to B	B to A	A to B	A to B	B to A
	Working pressure	M_B	M_A	M_A	M_B	M_A	M_B	M_B	M_A

▼ Position of ports (example)

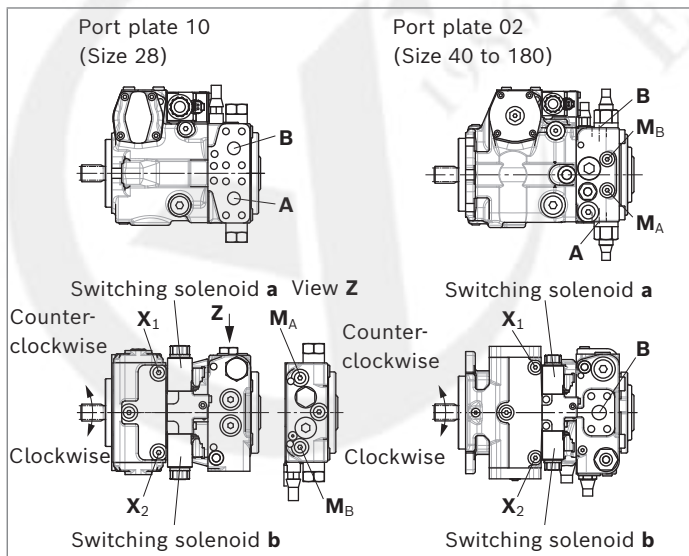

1) Size 28 without port F_{a1} and F_S

ET – Electric control, direct operated

The output flow of the pump is infinitely variable in the range between 0 and 100%. Depending on the preselected current I at solenoids **a** and **b** of the pressure reducing valves, the stroking cylinder of the pump is proportionally supplied with control pressure. The two control pressures X_1 and X_2 can be controlled independently. The pump displacement that arises at a certain control current is dependent on the rotational speed and working pressure of the pump. A different flow direction is associated with each pressure reducing valve.

Maximum permissible control pressure at port P_S : 40 bar.

Technical data, pressure reducing valve	ET3 ¹⁾	ET4 ¹⁾	ET7 ²⁾	ET8 ²⁾
On-board voltage in the vehicle	12 V	24 V	12 V	24 V
Permissible voltage U	9.6 ... 28.8 V		9.6 ... 28.8 V	
Current limit	1.8 A		1.45 A	
Nominal resistance (at 20 °C)	2.4 Ω		4.05 Ω	
Dither				
Frequency	100 Hz		100 Hz	
Minimum oscillation range ³⁾	360 mA		250 mA	
Duty cycle	100%		100%	
Type of protection: see connector version page 95				

▼ Circuit diagram ET3/4, standard version⁴⁾

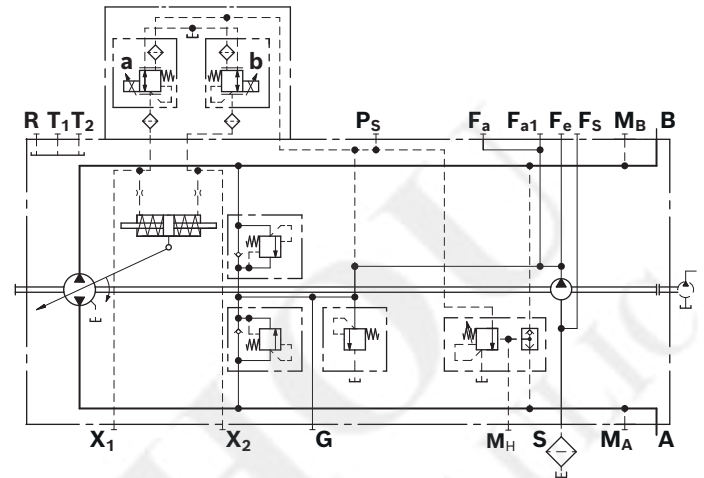

▼ Circuit diagram ET7/8, standard version

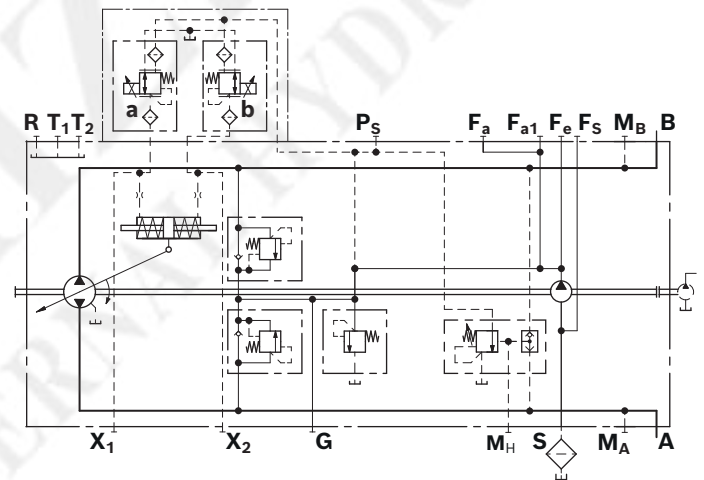

1) For further information on the pressure reducing valve, see data sheet 58032.

Notice: The leakage flow and the control flow differ from the parameter in data sheet 58032.

2) For further information on the pressure reducing valve, see data sheet 64659.

Notice: The leakage flow and the control flow differ from the parameter in data sheet 64659.

3) Minimum required oscillation range of the control current ΔI_{p-p} (peak to peak) within the respective control range (start of control to end of control)

4) Size 28 without port F_{a1} and F_S

Correlation of direction of rotation, control and flow direction

Direction of rotation		Clockwise				Counter-clockwise			
Size ¹⁾		28 ... 40		125		28 ... 40		125	
Actuation of pressure reducing valve		a	b	a	b	a	b	a	b
Control pressure		X₁	X₂	X₁	X₂	X₁	X₂	X₁	X₂
Port plate 02 and 10	Flow direction	A to B	B to A	B to A	A to B	B to A	A to B	A to B	B to A
	Working pressure	M_B	M_A	M_A	M_B	M_A	M_B	M_B	M_A
Port plate 03 and 13	Flow direction	B to A	A to B	A to B	B to A	A to B	B to A	B to A	A to B
	Working pressure	M_A	M_B	M_B	M_A	M_B	M_A	M_A	M_B

▼ **ET3/4 Position of ports (example)**

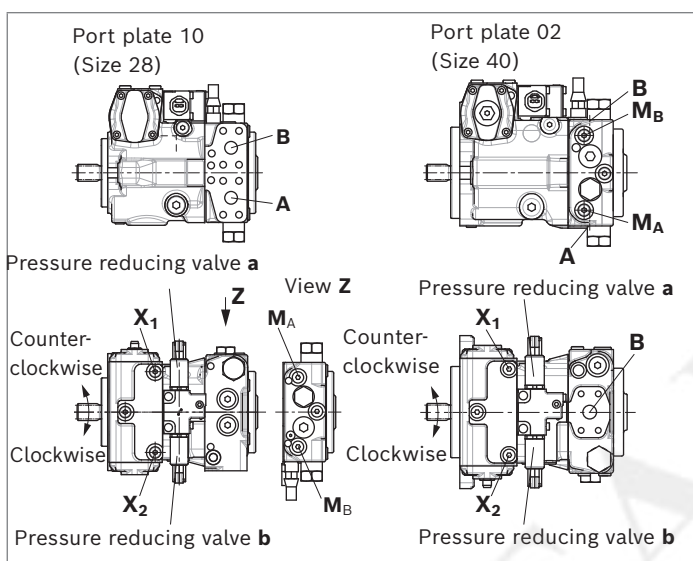

▼ **ET7/8 Position of ports**

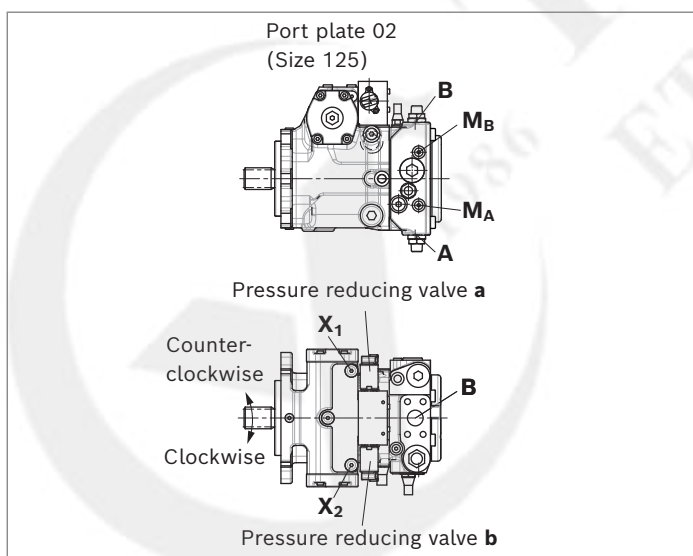

1) Depending on the size, different/not all port plates are available, see type code position 15

BT – BODAS electronic control

The BT control is intended to be used together with BODAS application software.

Here, all relevant configuration options have already been predefined. The pump function is largely determined by the software used.

Please check in the data sheet of the used BODAS application software whether it is compatible with the BT control.

Technical data, pressure reducing valve	BT1 ¹⁾	BT2 ¹⁾	BT1 ²⁾	BT2 ²⁾
	NG28, 40		NG125	
On-board voltage in the vehicle	12 V	24 V	12 V	24 V
Permissible voltage U	9.6 ... 28.8 V		9.6 ... 28.8 V	
Current limit	1.8 A		1.45 A	
Nominal resistance (at 20 °C)	2.4 Ω		4.05 Ω	
Dither				
Frequency	100 Hz		100 Hz	
Minimum oscillation range ³⁾	360 mA		250 mA	
Duty cycle	100%		100%	
Type of protection: see connector version page 95				

Notice

All control-relevant data are already stored in the software.

▼ Circuit diagram BT1/2, sizes 28 and 40⁴⁾

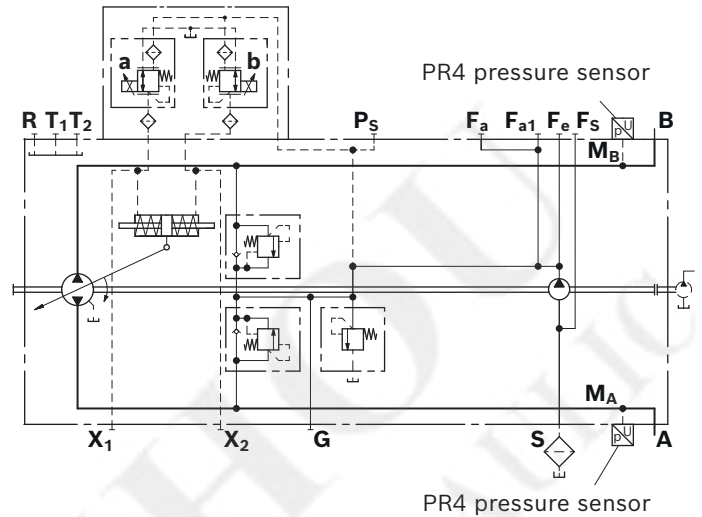

▼ Circuit diagram BT1/2, size 125

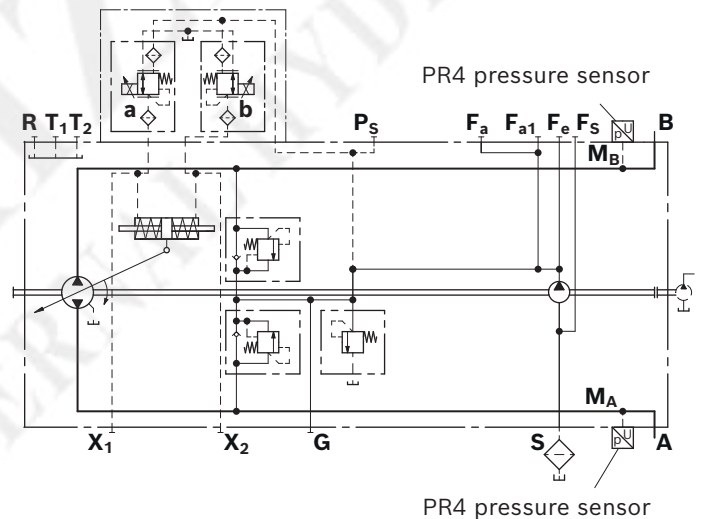

1) For further information on the pressure reducing valve, see data sheet 58032.

Notice: The leakage flow and the control flow differ from the parameter in data sheet 58032.

2) For further information on the pressure reducing valve, see data sheet 64659.

Notice: The leakage flow and the control flow differ from the parameter in data sheet 64659.

3) Minimum required oscillation range of the control current ΔI_{p-p} (peak to peak) within the respective control range (start of control to end of control)

4) Size 28 without port F_{a1} and F_s

Correlation of direction of rotation, control and flow direction

Direction of rotation	Clockwise				Counter-clockwise			
Size	28 ... 40		125		28 ... 40		125	
Actuation of solenoid	a	b	a	b	a	b	a	b
Control pressure	X₁	X₂	X₁	X₂	X₁	X₂	X₁	X₂
Flow direction	A to B	B to A	B to A	A to B	B to A	A to B	A to B	B to A
Working pressure	M_B	M_A	M_A	M_B	M_A	M_B	M_B	M_A

▼ **Position of ports**

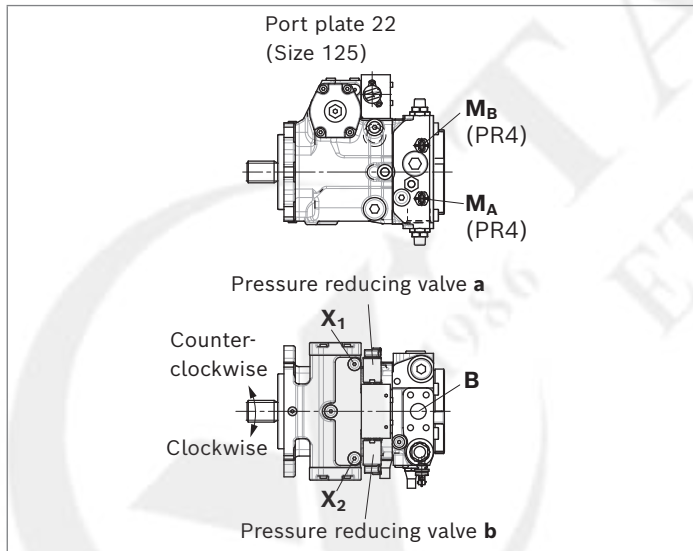
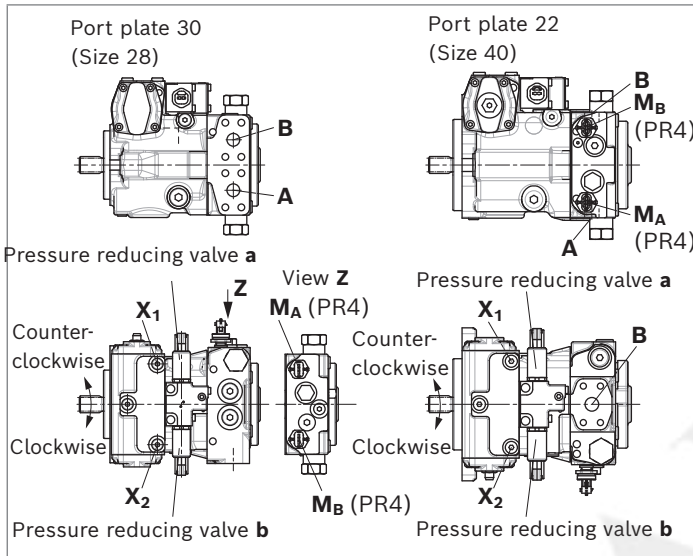

Dimensions, size 28

NV - Version without control module

Standard: SAE working port **A** and **B**, same side right, suction port **S** bottom (10)

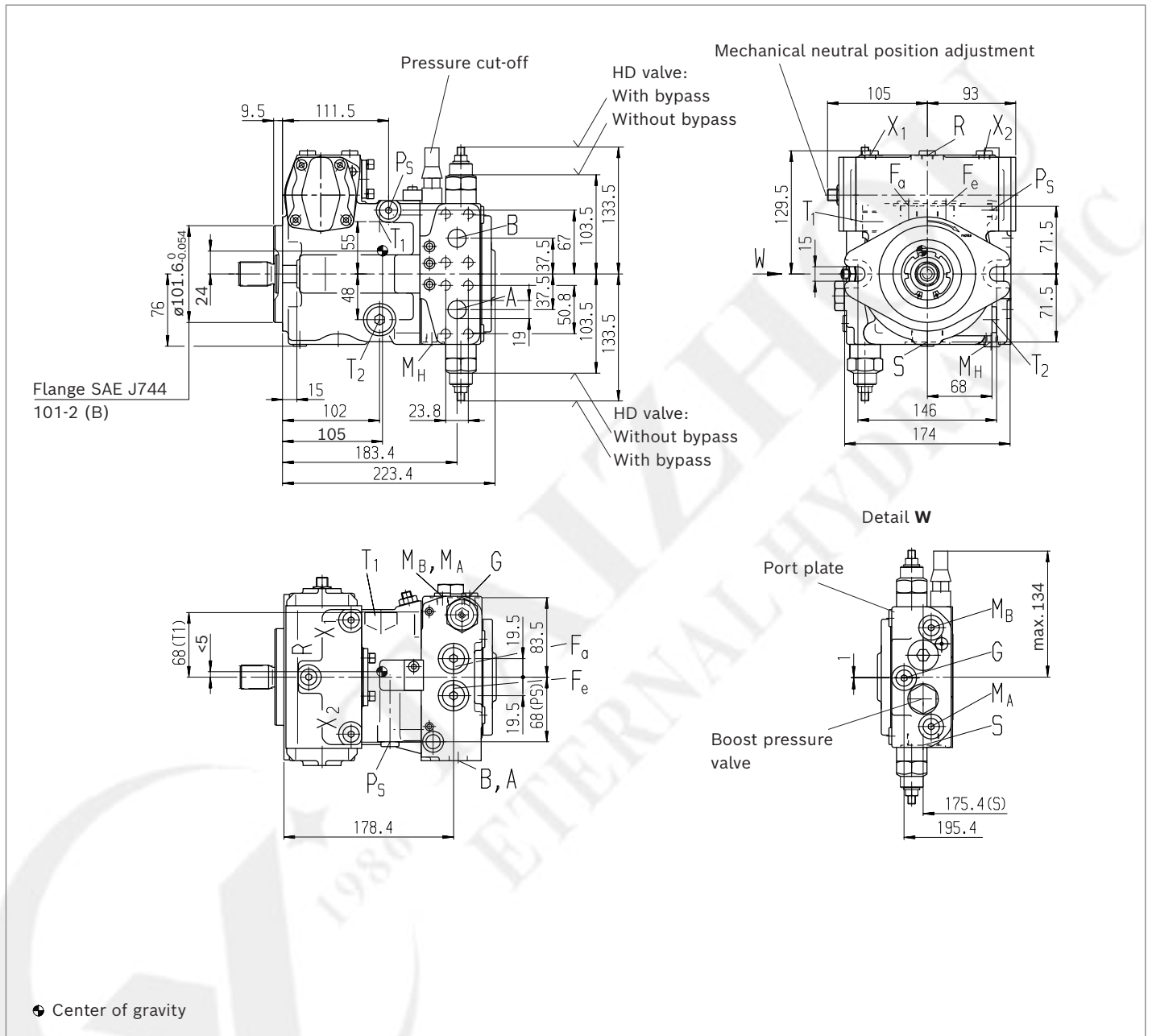

Notice

Option: SAE working port **A** and **B**, same side left, suction port **S** top (13): Port plate 10 rotated through 180°, installation drawing on request

▼ Splined shaft DIN 5480

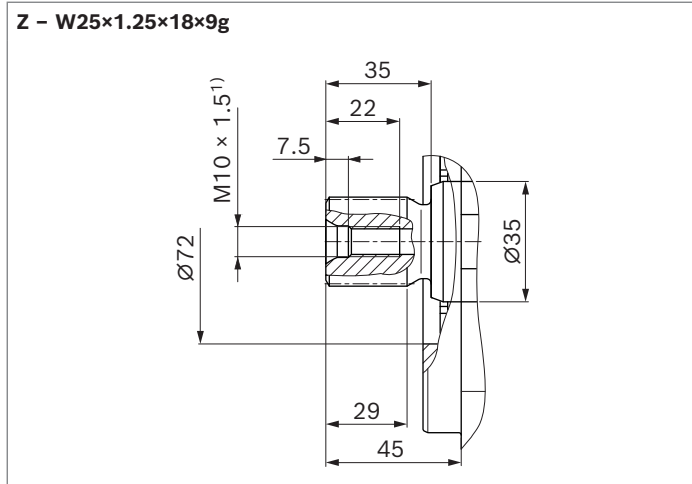

▼ Splined shaft ANSI B92.1a

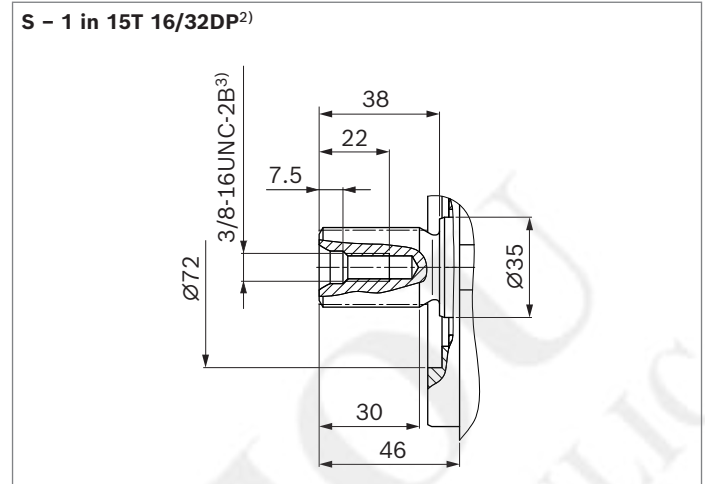

- 1) Center bore according to DIN 332 (thread according to DIN 13)
- 2) Involute spline according to ANSI B92.1a, 30° pressure angle, flat root, side fit, tolerance class 5
- 3) Thread according to ASME B1.1

▼ Connection table for port plate 10 and 13

Ports	Standard	Size	p_{max} [bar] ⁴⁾	State ¹¹⁾
A, B Working port Fastening thread	SAEJ518 ⁵⁾ DIN 13	3/4 in M10 × 1.5; 17 deep	450	O
S Suction port	DIN 3852 ⁸⁾	M33 × 2; 18 deep	5	O ⁶⁾
T₁ Drain port	DIN 3852 ⁸⁾	M22 × 1.5; 14 deep	3	O ⁷⁾
T₂ Drain port	DIN 3852 ⁸⁾	M22 × 1.5; 14 deep	3	X ⁷⁾
R Air bleed port	DIN 3852 ⁸⁾	M12 × 1.5; 12 deep	3	X
X₁, X₂ Control pressure port (upstream of orifice)	DIN 3852 ⁸⁾	M12 × 1.5; 12 deep	40	X
X₁, X₂ Control pressure port (upstream of orifice, DG only)	DIN 3852 ⁸⁾	M12 × 1.5; 12 deep	40	O
X₃, X₄ ⁹⁾ Stroking chamber pressure port	DIN 3852 ⁸⁾	M12 × 1.5; 12 deep	40	X
G Boost pressure port inlet	DIN 3852 ⁸⁾	M12 × 1.5; 12 deep	40	X
P_S Pilot pressure port	DIN 3852 ⁸⁾	M14 × 1.5; 12 deep	40	X
P_S Pilot pressure port (DA..7 only)	DIN 3852 ⁸⁾	M14 × 1.5; 12 deep	40	O
Y Pilot pressure port outlet (only DA..7)	DIN 3852 ⁸⁾	M14 × 1.5; 12 deep	40	O
M_A, M_B Measuring port pressure A, B	DIN 3852 ⁸⁾	M12 × 1.5; 12 deep	450	X
M_H Measuring port, high pressure	DIN 3852 ⁸⁾	M12 × 1.5; 12 deep	450	X
F_a Boost pressure port inlet	DIN 3852 ⁸⁾	M18 × 1.5; 12 deep	40	X
F_e Boost pressure port outlet	DIN 3852 ⁸⁾	M18 × 1.5; 12 deep	40	X
Y₁, Y₂ Pilot pressure port (pilot signal HD only)	DIN 3852 ⁸⁾	M14 × 1.5; 12 deep	40	O
Z Pilot pressure port (inch signal only DA..8)	DIN 3852 ⁸⁾	M10 × 1; 8 deep	80	X

▼ Connection table for port plate 30

Ports	Standard	Size	p_{max} [bar] ⁴⁾	State ¹¹⁾
A, B Working port Fastening thread	SAEJ518 ⁵⁾ DIN 13	3/4 in M10 × 1.5; 17 deep	450	O
S Suction port	ISO 6149 ¹⁰⁾	M33 × 2; 19 deep	5	O ⁶⁾
T₁ Drain port	ISO 6149 ¹⁰⁾	M22 × 1.5; 14 deep	3	O ⁷⁾
T₂ Drain port	ISO 6149 ¹⁰⁾	M22 × 1.5; 14 deep	3	X ⁷⁾
R Air bleed port	ISO 6149 ¹⁰⁾	M12 × 1.5; 12 deep	3	X
X₁, X₂ Control pressure port (upstream of orifice)	ISO 6149 ¹⁰⁾	M12 × 1.5; 12 deep	40	X
G Boost pressure port inlet	ISO 6149 ¹⁰⁾	M14 × 1.5; 11.5 deep	40	X
P_S Pilot pressure port	ISO 6149 ¹⁰⁾	M14 × 1.5; 12 deep	40	X
M_A, M_B Measuring port pressure A, B	ISO 6149 ¹⁰⁾	M14 × 1.5; 11.5 deep	450	X
F_a Boost pressure port inlet	ISO 6149 ¹⁰⁾	M18 × 1.5; 14.5 deep	40	X
F_e Boost pressure port outlet	ISO 6149 ¹⁰⁾	M18 × 1.5; 14.5 deep	40	X

4) Depending on the application, momentary pressure peaks can occur. Keep this in mind when selecting measuring devices and fittings.

5) Only dimensions according to SAE J518, metric fastening thread is a deviation from the standard.

6) Plugged for external boost pressure supply.

7) Depending on installation position, **T₁** or **T₂** must be connected (see also installation instructions on page 98).

8) The countersink may be deeper than specified in the standard. Ports designed for straight stud ends according to EN ISO 9974-2 type E

9) Optional, see page 88

10) The countersink may be deeper than specified in the standard. Ports designed for straight stud ends according to EN ISO 6149-2

11) O = Must be connected (plugged on delivery)

X = Plugged (observe installation instructions)

▼ **HD** – Proportional control, hydraulic, pilot-pressure related

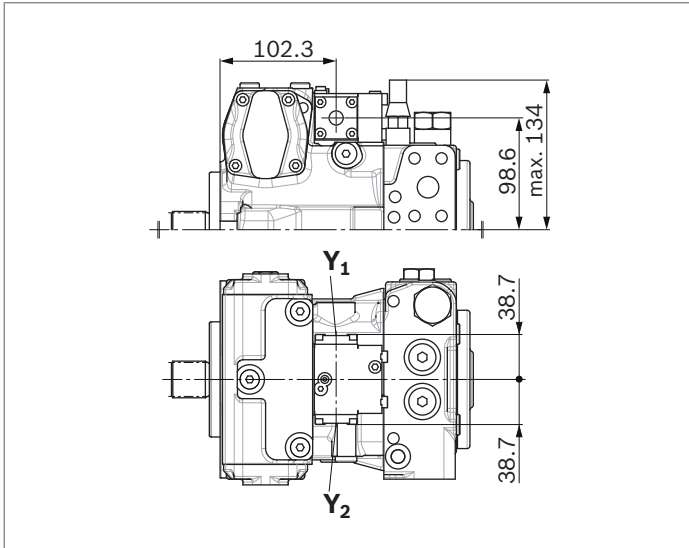

▼ **HW** – Proportional control, hydraulic, mechanical servo

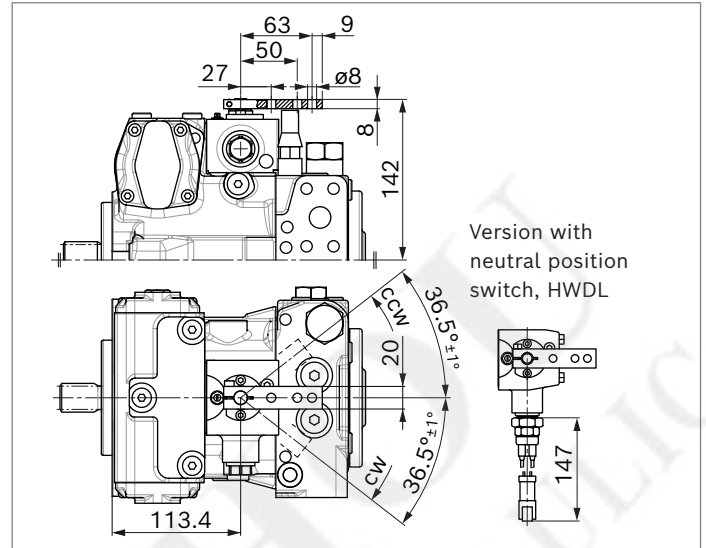

▼ **EP** – Proportional control, electric

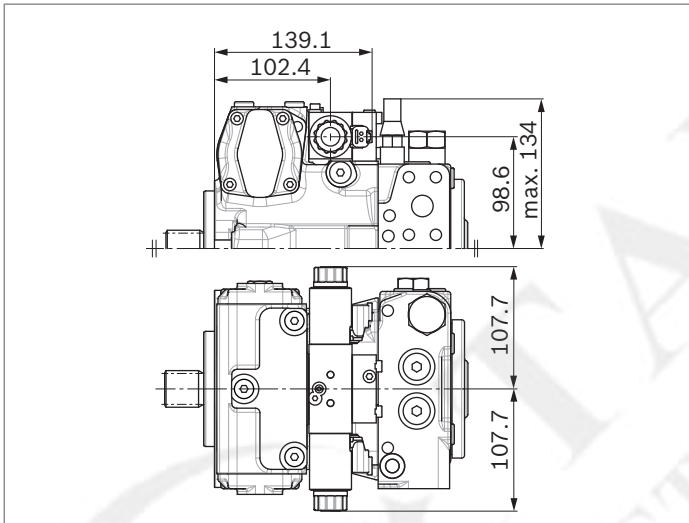

▼ **EZ** – Two-point control, electric



▼ **DG** – Hydraulic control, direct operated

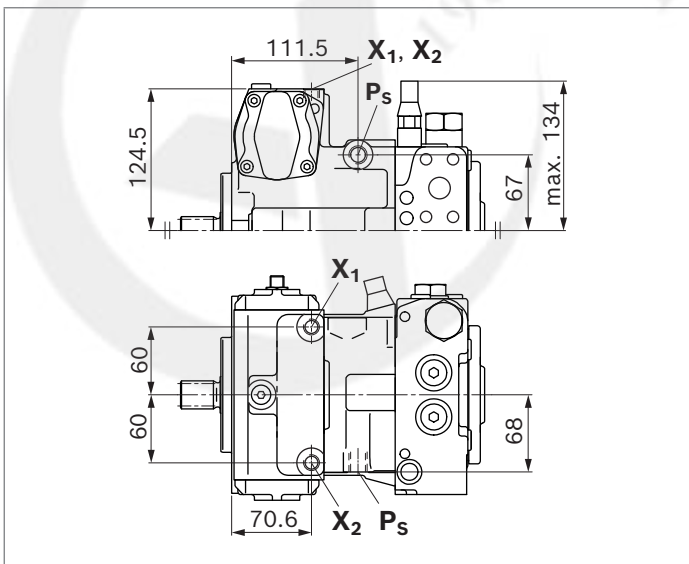

▼ **ET** – Electric control, direct operated, two FTDRE

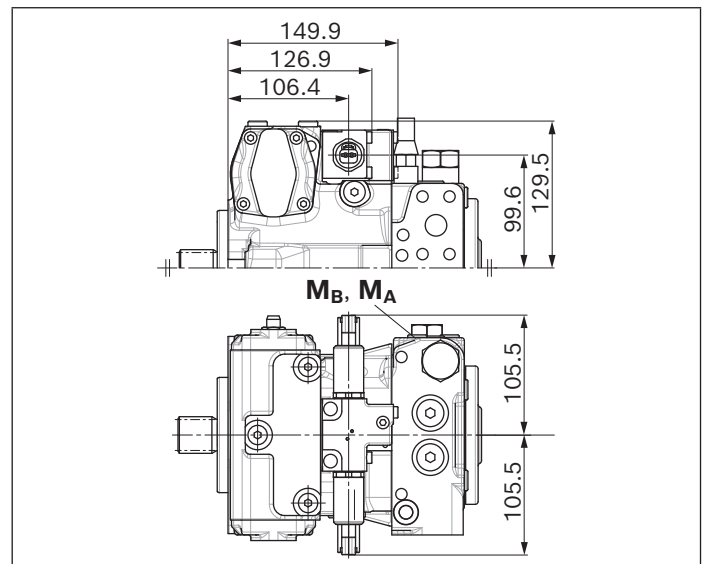

▼ **BT** – BODAS electronic control

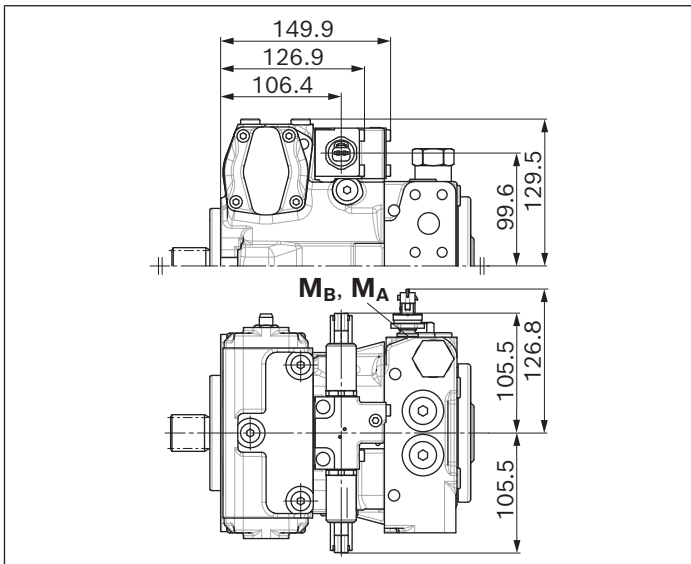

DA control valve

▼ **DA..2** – Fixed setting

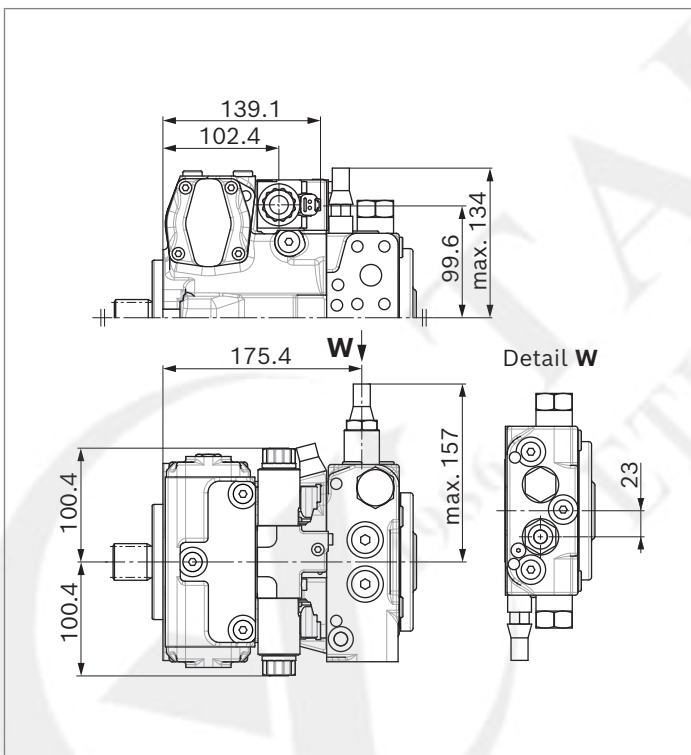

▼ **DA..3** – Mechanically adjustable with position lever

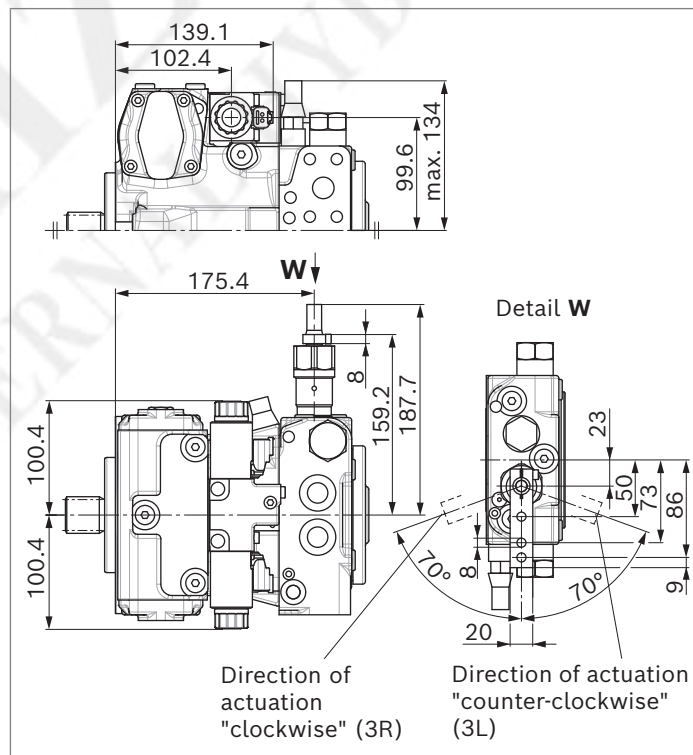

▼ DA..7 – Fixed setting and ports for pilot control device

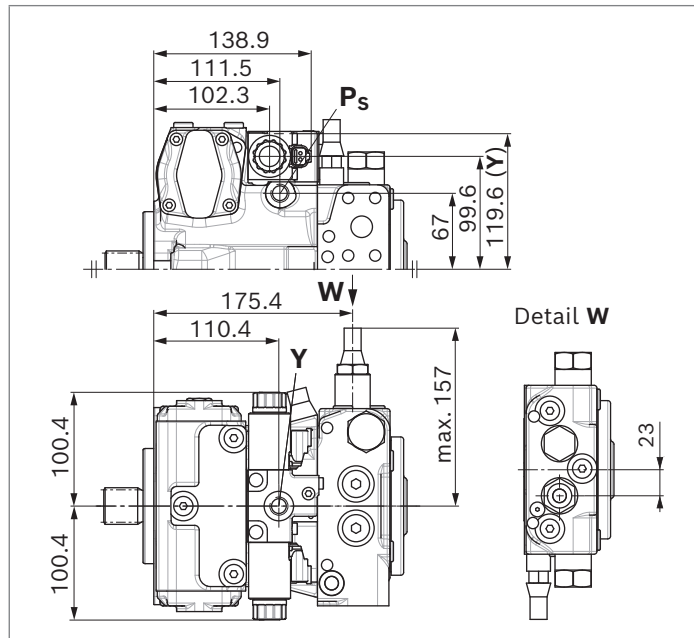

▼ DA..8 – Fixed setting and inch valve mounted

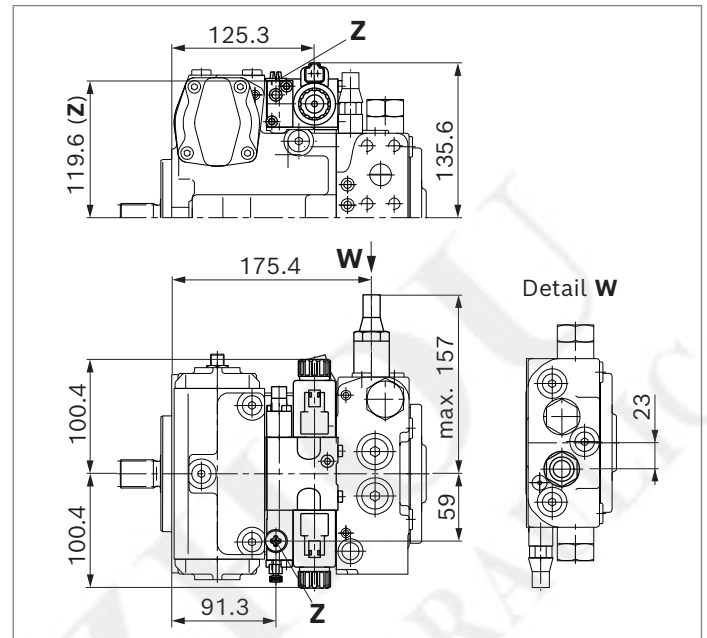

Dimensions, size 40

NV - Version without control module

Standard: SAE working port **A** and **B** top and bottom, suction port **S** bottom (02)

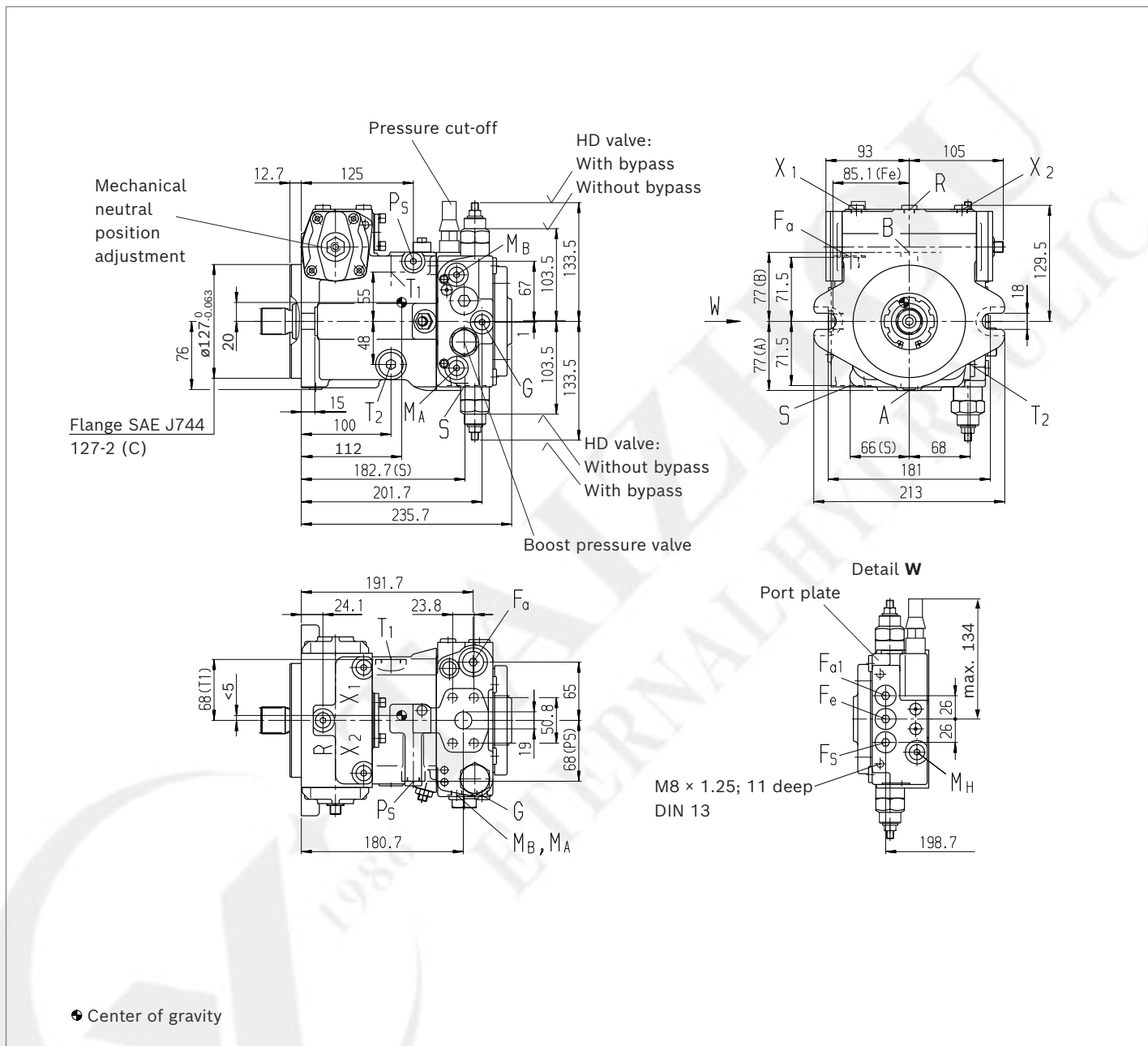

Notice

Option: SAE working port **A** and **B** top and bottom, suction port **S** top (03), port plate (02) rotated through 180°, installation drawing on request

▼ Splined shaft DIN 5480

Z - W30×2×14×9g

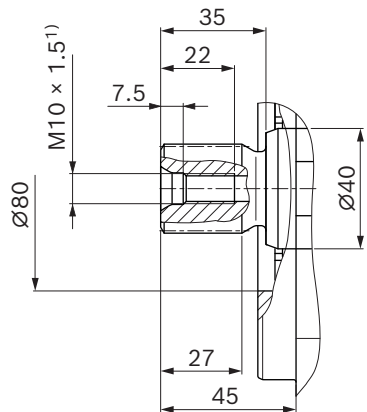

▼ Splined shaft DIN 5480

A - W35×2×16×9g

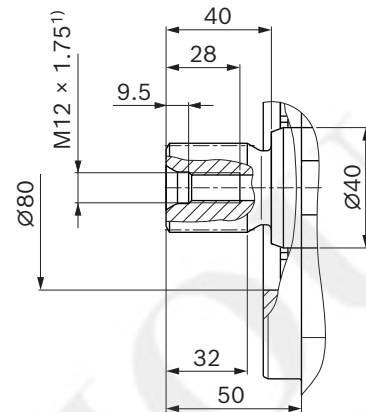

▼ Splined shaft ANSI B92.1a

S - 1 1/4 in 14T 12/24DP²⁾

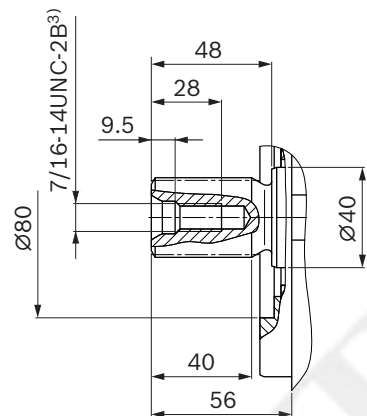

▼ Splined shaft ANSI B92.1a

U - 1 in 15T 16/32DP²⁾

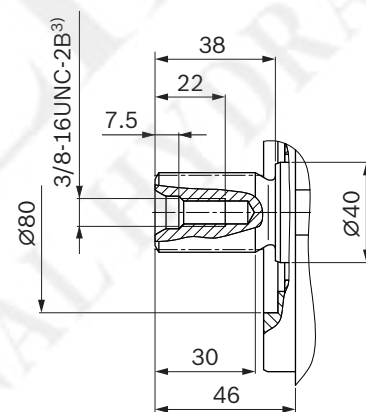

1) Center bore according to DIN 332 (thread according to DIN 13)
2) Involute spline according to ANSI B92.1a, 30° pressure angle, flat root, side fit, tolerance class 5
3) Thread according to ASME B1.1

▼ Connection table for port plate 02 and 03

Ports	Standard	Size	p_{max} [bar] ⁴⁾	State ¹²⁾
A, B Working port Fastening thread	SAEJ518 ⁵⁾ DIN 13	3/4 in M10 × 1.5; 17 deep	450	O
S Suction port	DIN 3852 ⁸⁾	M33 × 2; 18 deep	5	O ⁶⁾
T₁ Drain port	DIN 3852 ⁸⁾	M22 × 1.5; 14 deep	3	O ⁷⁾
T₂ Drain port	DIN 3852 ⁸⁾	M22 × 1.5; 14 deep	3	X ⁷⁾
R Air bleed port	DIN 3852 ⁸⁾	M12 × 1.5; 12 deep	3	X
X₁, X₂ Control pressure port (upstream of orifice)	DIN 3852 ⁸⁾	M12 × 1.5; 12 deep	40	X
X₁, X₂ Control pressure port (upstream of orifice, DG only)	DIN 3852 ⁸⁾	M12 × 1.5; 12 deep	40	O
X₃, X₄ ⁹⁾ Stroking chamber pressure port	DIN 3852 ⁸⁾	M12 × 1.5; 12 deep	40	X
G Boost pressure port inlet	DIN 3852 ⁸⁾	M12 × 1.5; 12 deep	40	X
P_S Pilot pressure port	DIN 3852 ⁸⁾	M14 × 1.5; 12 deep	40	X
P_S Pilot pressure port (DA..7 only)	DIN 3852 ⁸⁾	M14 × 1.5; 12 deep	40	O
Y Pilot pressure port outlet (only DA..7)	DIN 3852 ⁸⁾	M14 × 1.5; 12 deep	40	O
M_A, M_B Measuring port pressure A, B	DIN 3852 ⁸⁾	M12 × 1.5; 12 deep	450	X
M_H Measuring port, high pressure	DIN 3852 ⁸⁾	M12 × 1.5; 12 deep	450	X
F_a Boost pressure port inlet	DIN 3852 ⁸⁾	M18 × 1.5; 12 deep	40	X
F_{a1} ¹⁰⁾ Boost pressure port inlet (attachment filter)	DIN 3852 ⁸⁾	M18 × 1.5; 12 deep	40	X
F_e ¹⁰⁾ Boost pressure port outlet	DIN 3852 ⁸⁾	M18 × 1.5; 12 deep	40	X
F_S ¹⁰⁾ Line from filter to suction port (cold start)	DIN 3852 ⁸⁾	M18 × 1.5; 12 deep	40	X
Y₁, Y₂ Pilot pressure port (pilot signal HD only)	DIN 3852 ⁸⁾	M14 × 1.5; 12 deep	40	O
Z Pilot pressure port (inch signal only DA..8)	DIN 3852 ⁸⁾	M10 × 1; 8 deep	80	X

▼ Connection table for port plate 22

Ports	Standard	Size	p_{max} [bar] ⁴⁾	State ¹²⁾
A, B Working port Fastening thread	SAEJ518 ⁵⁾ DIN 13	3/4 in M10 × 1.5; 17 deep	450	O
S Suction port	ISO 6149 ¹¹⁾	M33 × 2; 19 deep	5	O ⁶⁾
T₁ Drain port	ISO 6149 ¹¹⁾	M22 × 1.5; 14 deep	3	O ⁷⁾
T₂ Drain port	ISO 6149 ¹¹⁾	M22 × 1.5; 14 deep	3	X ⁷⁾
R Air bleed port	ISO 6149 ¹¹⁾	M12 × 1.5; 12 deep	3	X
X₁, X₂ Control pressure port (upstream of orifice)	ISO 6149 ¹¹⁾	M12 × 1.5; 12 deep	40	X
G Boost pressure port inlet	ISO 6149 ¹¹⁾	M14 × 1.5; 11.5 deep	40	X
P_S Pilot pressure port	ISO 6149 ¹¹⁾	M14 × 1.5; 12 deep	40	X
M_A, M_B Measuring port pressure A, B	ISO 6149 ¹¹⁾	M14 × 1.5; 11.5 deep	450	X
F_a Boost pressure port inlet	ISO 6149 ¹¹⁾	M18 × 1.5; 14.5 deep	40	X
F_{a1} ¹⁰⁾ Boost pressure port inlet (attachment filter)	DIN 3852 ⁸⁾	M18 × 1.5; 12 deep	40	X
F_e ¹⁰⁾ Boost pressure port outlet	DIN 3852 ⁸⁾	M18 × 1.5; 12 deep	40	X
F_S ¹⁰⁾ Line from filter to suction port (cold start)	DIN 3852 ⁸⁾	M18 × 1.5; 12 deep	40	X

4) Depending on the application, momentary pressure peaks can occur.

Keep this in mind when selecting measuring devices and fittings.

5) Only dimensions according to SAE J518, metric fastening thread is a deviation from the standard.

6) Plugged for external boost pressure supply.

7) Depending on installation position, **T₁** or **T₂** must be connected (see also installation instructions on page 98).

8) The countersink may be deeper than specified in the standard. Ports designed for straight stud ends according to EN ISO 9974-2 type E

9) Optional, see page 88

10) The diameter of the countersink deviates from the standard. (For details, see page 91, dimensions of the countersinks)

11) The countersink may be deeper than specified in the standard. Ports designed for straight stud ends according to EN ISO 6149-2

12) O = Must be connected (plugged on delivery)
X = Plugged (in normal operation)

▼ **HD** – Proportional control, hydraulic, pilot-pressure related

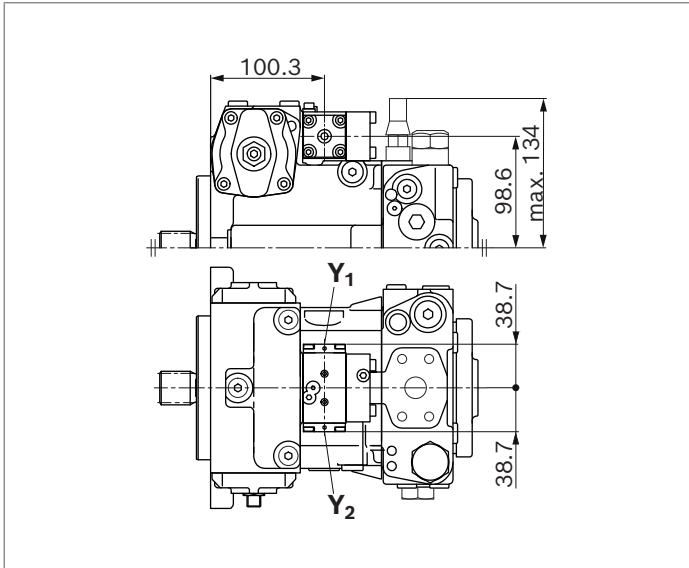

▼ **HW** – Proportional control, hydraulic, mechanical servo

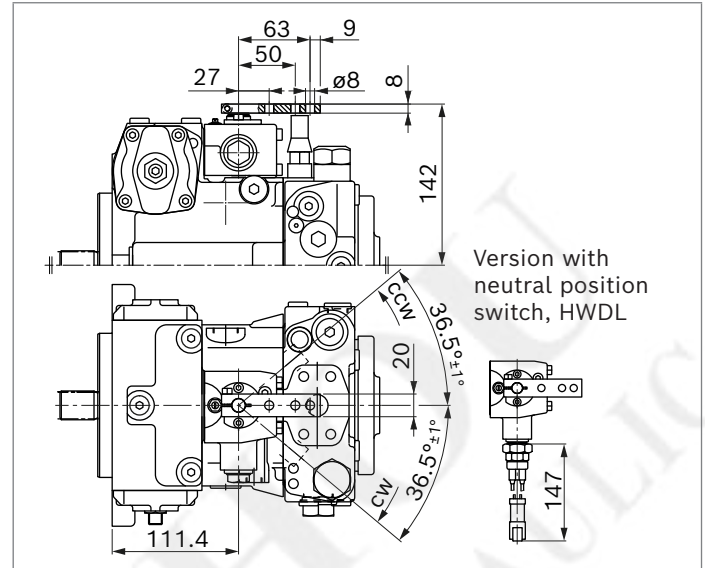

▼ **EP** – Proportional control, electric

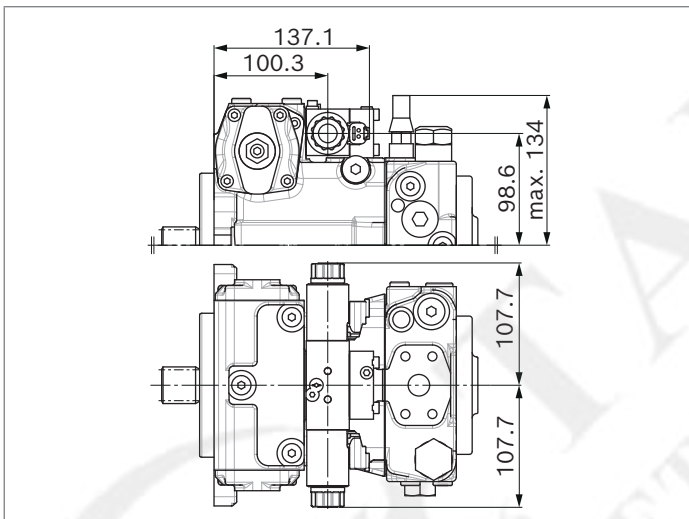

▼ **EZ** – Two-point control, electric

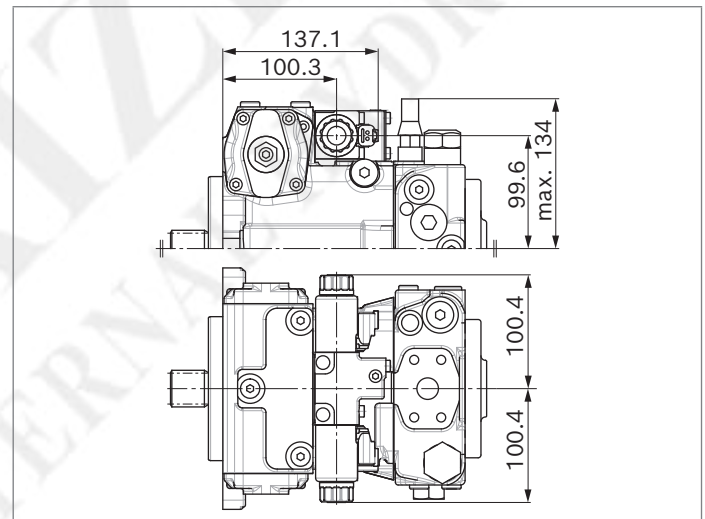

▼ **DG** – Hydraulic control, direct operated

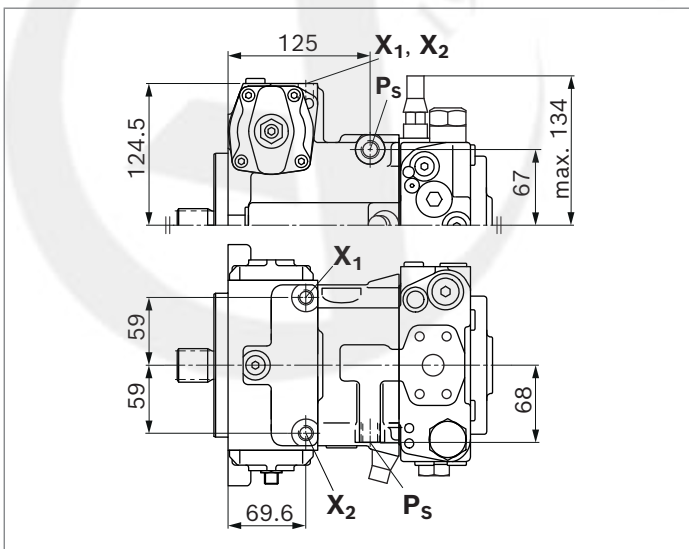

▼ **ET** – Electric control, direct operated, two FTDRE

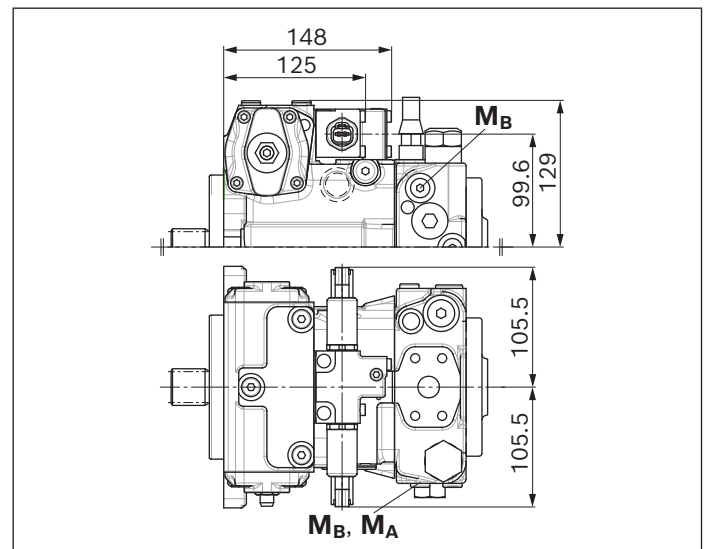

▼ **BT** – BODAS electronic control

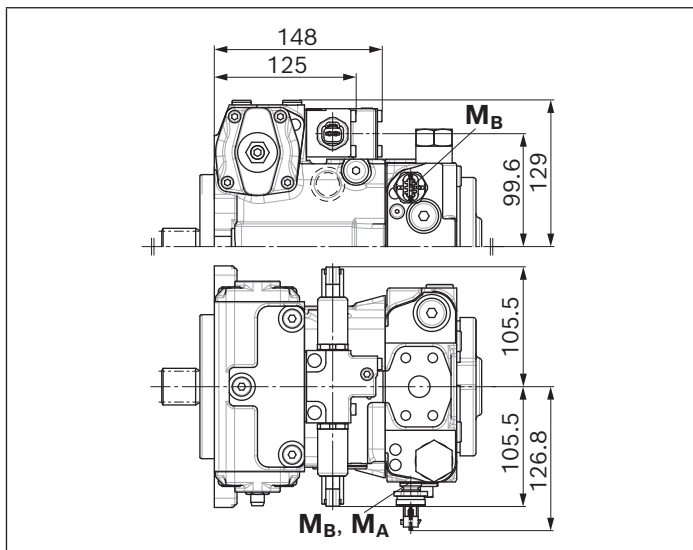

DA control valve

▼ **DA..2** – Fixed setting

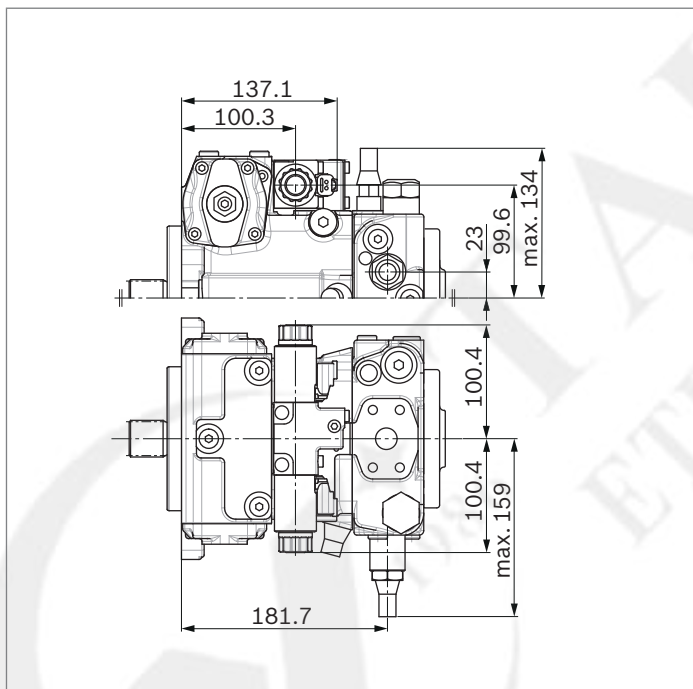

▼ **DA..3** – Mechanically adjustable with position lever

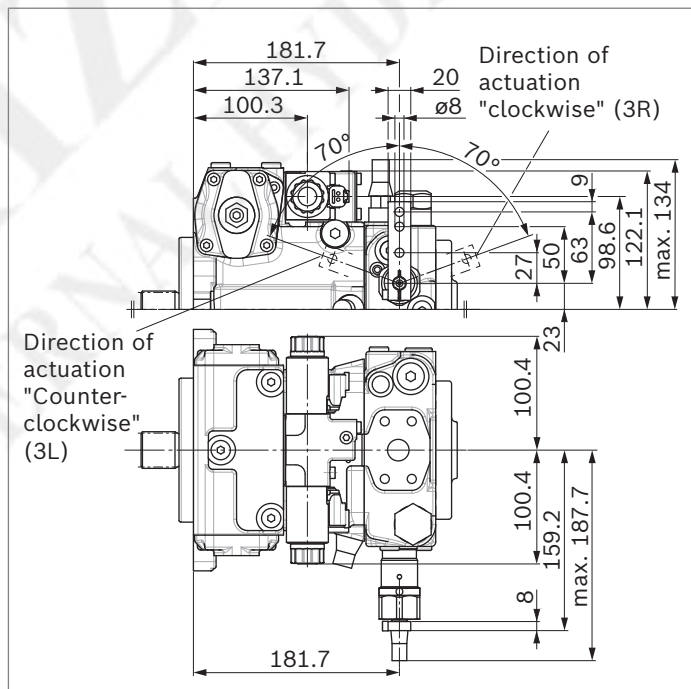

▼ DA..7 – Fixed setting and ports for pilot control device

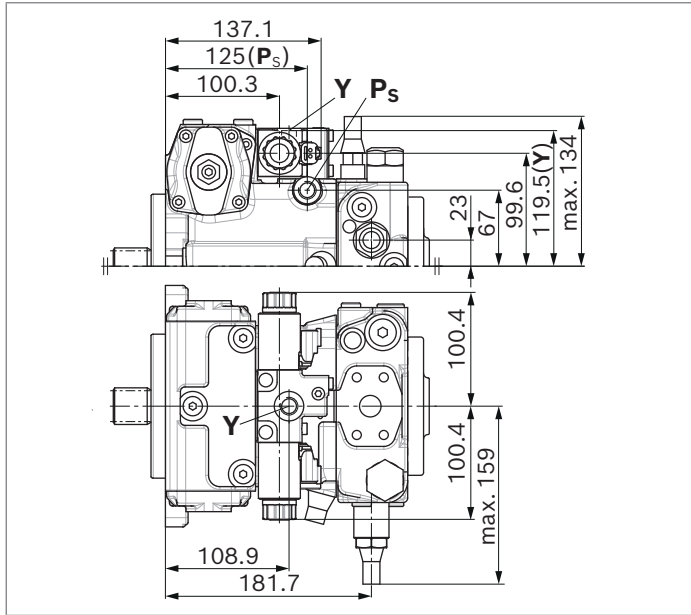

▼ DA..8 – Fixed setting and inch valve mounted

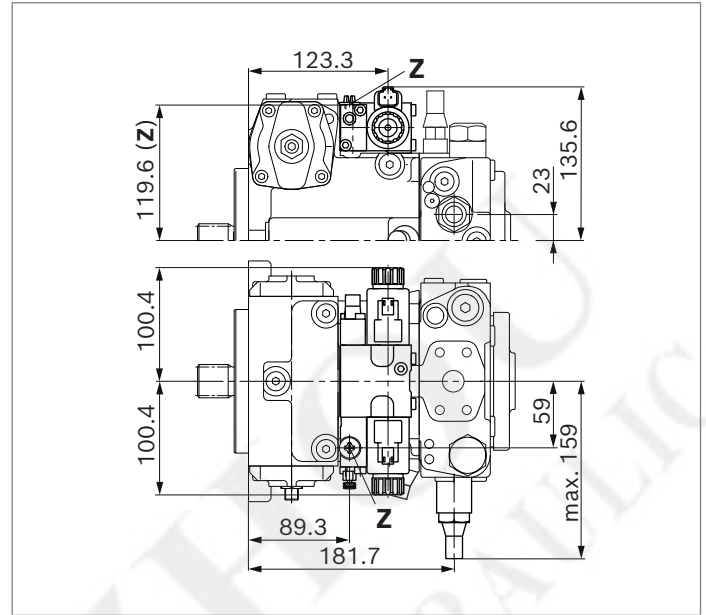

Dimensions, size 56

NV - Version without control module

Standard: SAE working port **A** and **B** top and bottom, suction port **S** bottom (02)

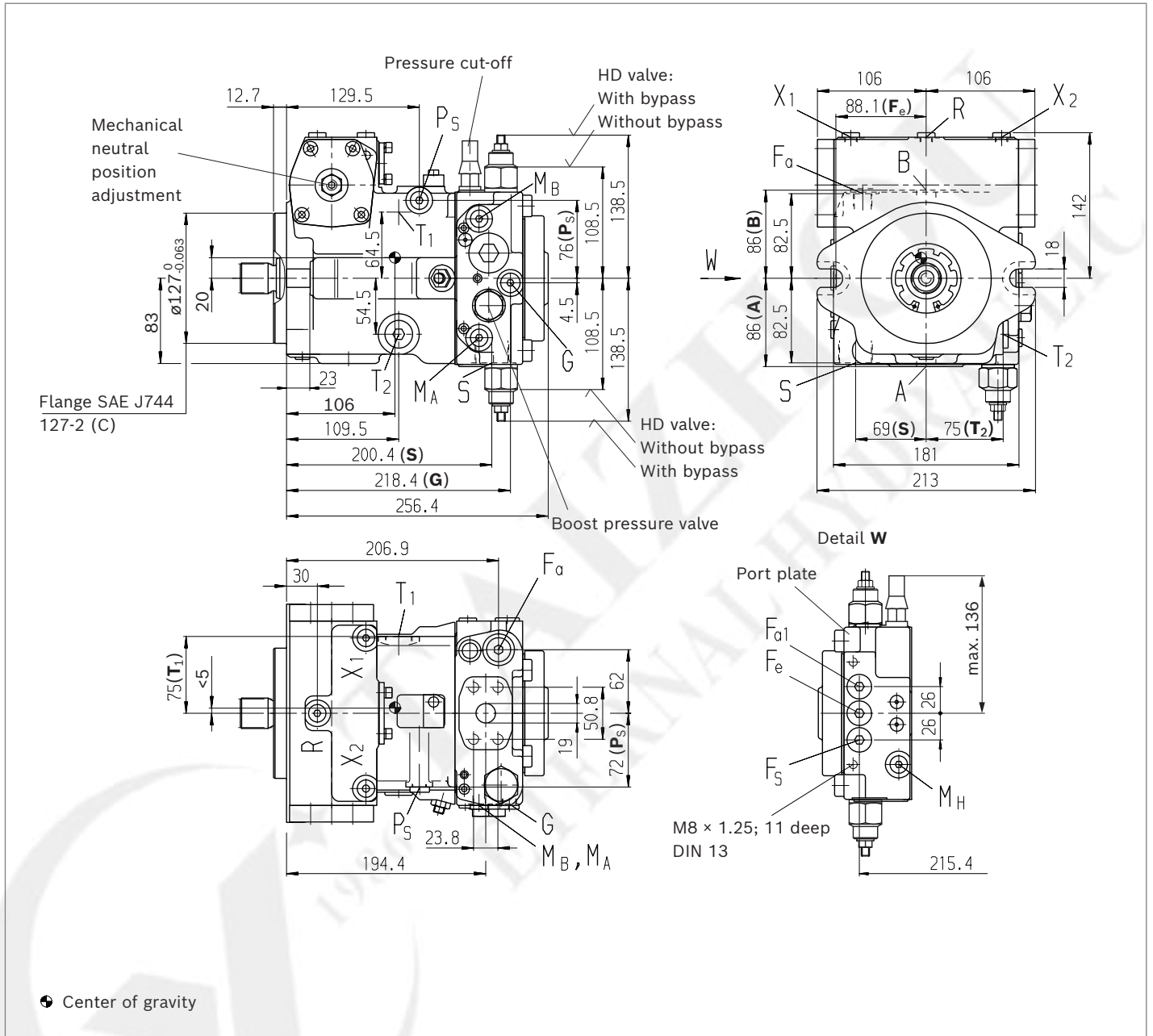

Notice

Option: SAE working port **A** and **B** top and bottom, suction port **S** top (03), port plate (02) rotated through 180°, installation drawing on request

NV - Version without control module

Option: SAE working port **A** and **B**, same side left, suction port **S** top (13)

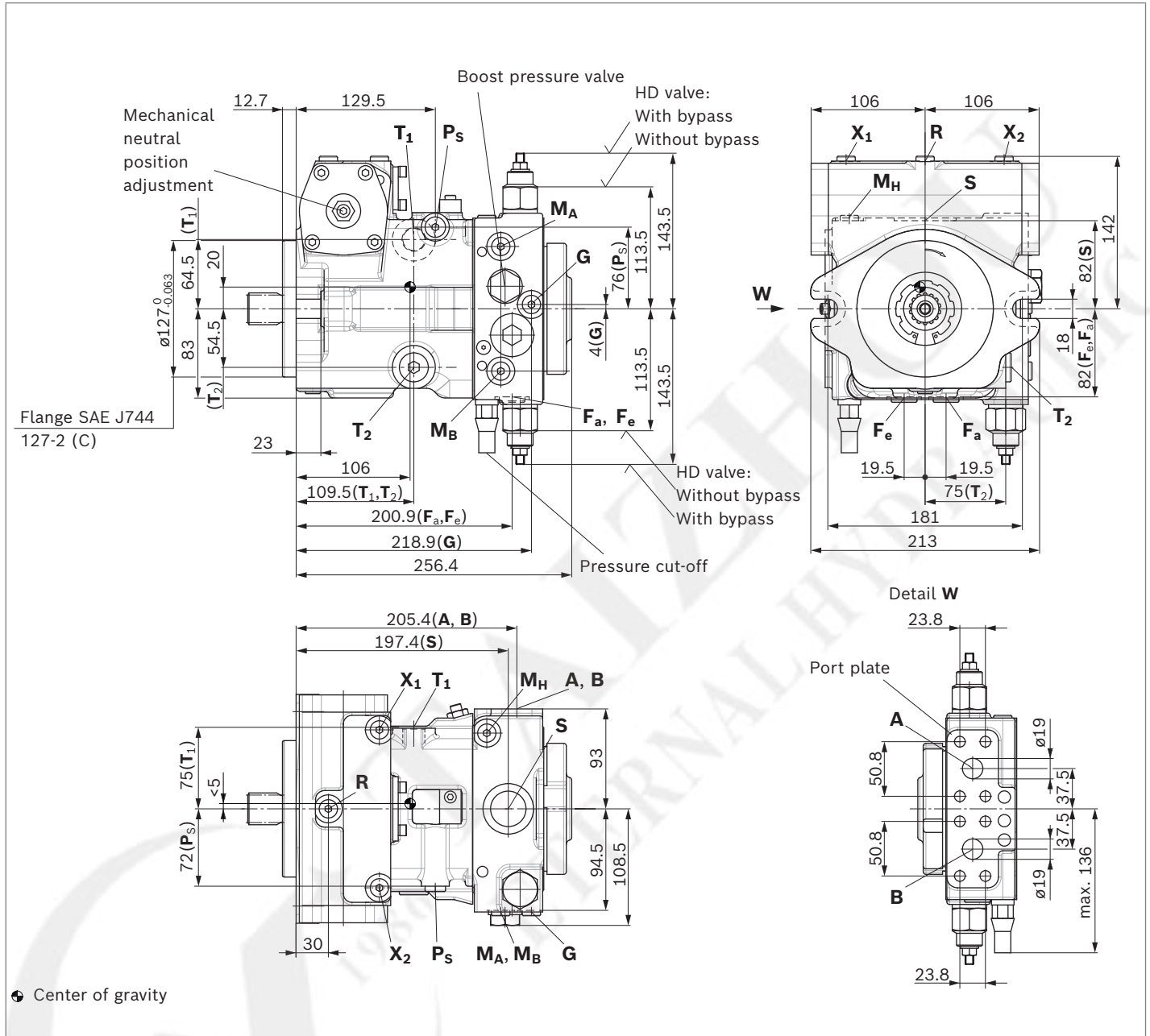

▼ Splined shaft DIN 5480

Z - W30x2x14x9g

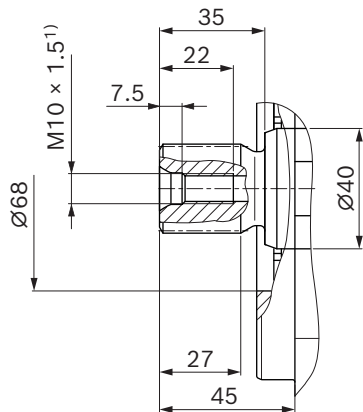

▼ Splined shaft DIN 5480

A - W35x2x16x9g

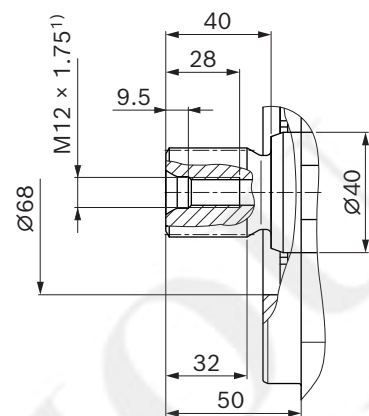

▼ Splined shaft ANSI B92.1a

S - 1 1/4 in 14T 12/24DP²⁾

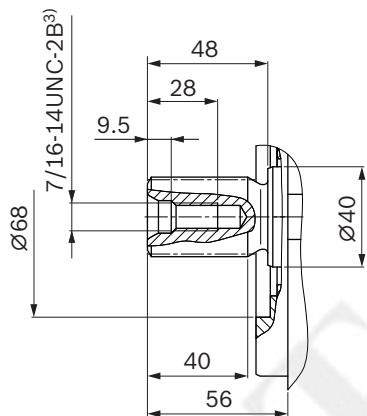

▼ Splined shaft ANSI B92.1a

T - 1 3/8 in 21T 16/32DP²⁾

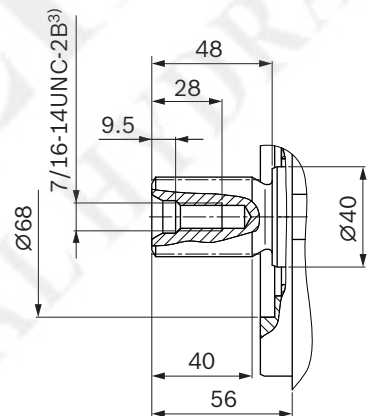

1) Center bore according to DIN 332 (thread according to DIN 13)
 2) Involute spline according to ANSI B92.1a, 30° pressure angle, flat root, side fit, tolerance class 5
 3) Thread according to ASME B1.1

Ports		Standard	Size	p_{\max} [bar] ⁴⁾	State ¹⁰⁾
A, B	Working port	SAEJ518 ⁵⁾	3/4 in	450	O
	Fastening thread	DIN 13	M10 × 1.5; 17 deep		
S	Suction port	DIN 3852 ⁸⁾	M33 × 2; 18 deep	5	O ⁶⁾
T₁	Drain port	DIN 3852 ⁸⁾	M22 × 1.5; 14 deep	3	O ⁷⁾
T₂	Drain port	DIN 3852 ⁸⁾	M22 × 1.5; 14 deep	3	X ⁷⁾
R	Air bleed port	DIN 3852 ⁸⁾	M12 × 1.5; 12 deep	3	X
X₁, X₂	Control pressure port (upstream of orifice)	DIN 3852 ⁸⁾	M12 × 1.5; 12 deep	40	X
X₁, X₂	Control pressure port (upstream of orifice, DG only)	DIN 3852 ⁸⁾	M12 × 1.5; 12 deep	40	O
X₃, X₄ ⁹⁾	Stroking chamber pressure port	DIN 3852 ⁸⁾	M12 × 1.5; 12 deep	40	X
G	Boost pressure port inlet	Working port A/B top and bottom	DIN 3852 ⁸⁾	M14 × 1.5; 12 deep	X
		Working port A/B lateral	DIN 3852 ⁸⁾	M12 × 1.5; 12 deep	X
P_S	Pilot pressure port	DIN 3852 ⁸⁾	M14 × 1.5; 12 deep	40	X
P_S	Pilot pressure port (DA..7 only)	DIN 3852 ⁸⁾	M14 × 1.5; 12 deep	40	O
Y	Pilot pressure port outlet (only DA..7)	DIN 3852 ⁸⁾	M14 × 1.5; 12 deep	40	O
M_A, M_B	Measuring port pressure A, B	DIN 3852 ⁸⁾	M12 × 1.5; 12 deep	450	X
M_H	Measuring port, high pressure	DIN 3852 ⁸⁾	M12 × 1.5; 12 deep	450	X
F_a	Boost pressure port inlet	DIN 3852 ⁸⁾	M18 × 1.5; 12 deep	40	X
F_{a1} ¹⁰⁾	Boost pressure port inlet (attachment filter)	DIN 3852 ⁸⁾	M18 × 1.5; 12 deep	40	X
F_e ¹⁰⁾	Boost pressure port outlet	DIN 3852 ⁸⁾	M18 × 1.5; 12 deep	40	X
F_S ¹⁰⁾	Line from filter to suction port (cold start)	DIN 3852 ⁸⁾	M18 × 1.5; 12 deep	40	X
Y₁, Y₂	Pilot pressure port (pilot signal HD only)	DIN 3852 ⁸⁾	M14 × 1.5; 12 deep	40	O
Z	Pilot pressure port (inch signal only DA..8)	DIN 3852 ⁸⁾	M10 × 1; 8 deep	80	X

4) Depending on the application, momentary pressure peaks can occur. Keep this in mind when selecting measuring devices and fittings.

5) Only dimensions according to SAE J518, metric fastening thread is a deviation from the standard.

6) Plugged for external boost pressure supply.

7) Depending on installation position, **T₁** or **T₂** must be connected (see also installation instructions on page 98).

8) The countersink can be deeper than specified in the standard. Ports designed for straight stud ends according to EN ISO 9974-2 type E

9) Optional, see page 88

10) The diameter of the countersink deviates from the standard. (For details, see page 91, dimensions of the countersinks)

11) O = Must be connected (plugged on delivery)

X = Plugged (in normal operation)

▼ **HD** – Proportional control, hydraulic, pilot-pressure related

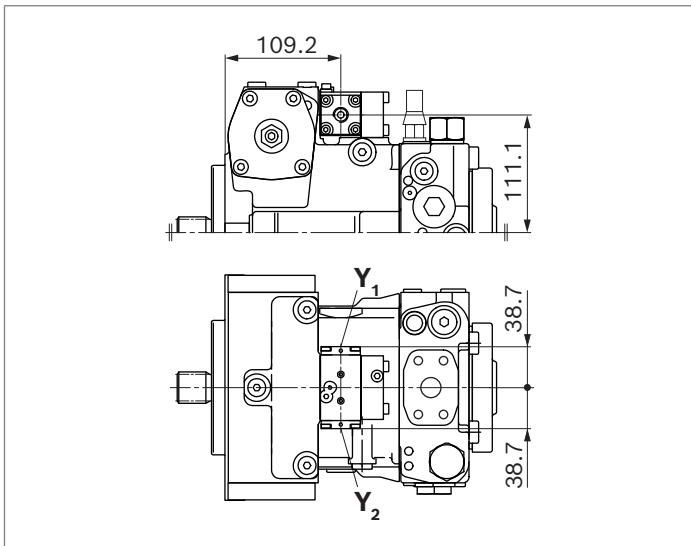

▼ **HW** – Proportional control, hydraulic, mechanical servo

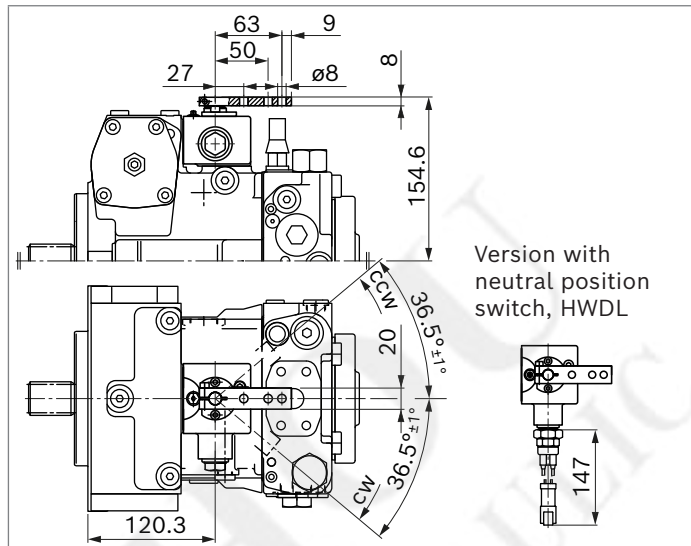

▼ **EP** – Proportional control, electric

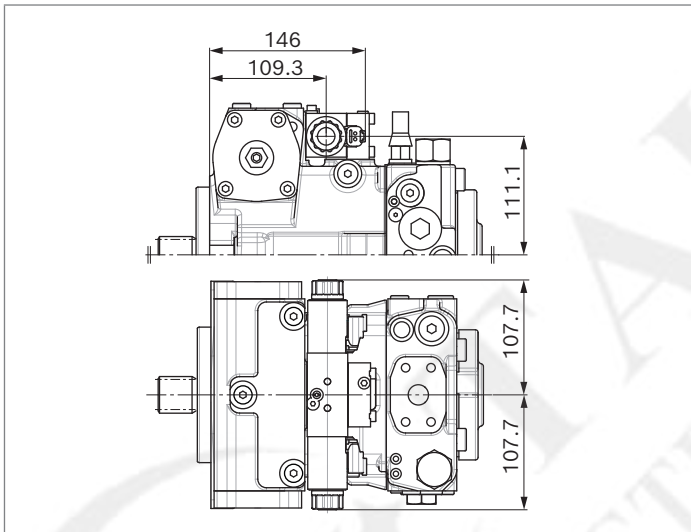

▼ **EZ** – Two-point control, electric

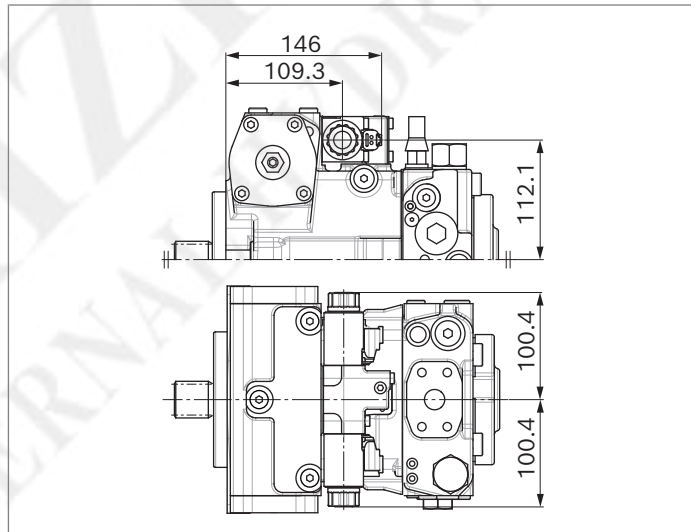

▼ **DG** – Hydraulic control, direct operated

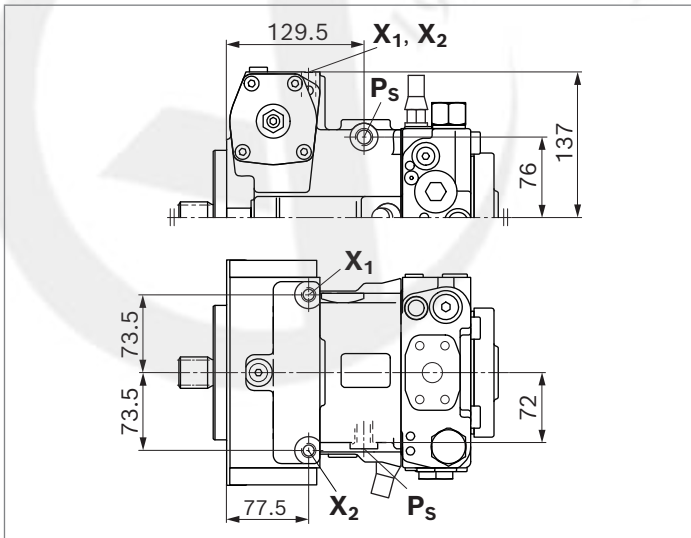

DA control valve

▼ **DA..2** – Fixed setting

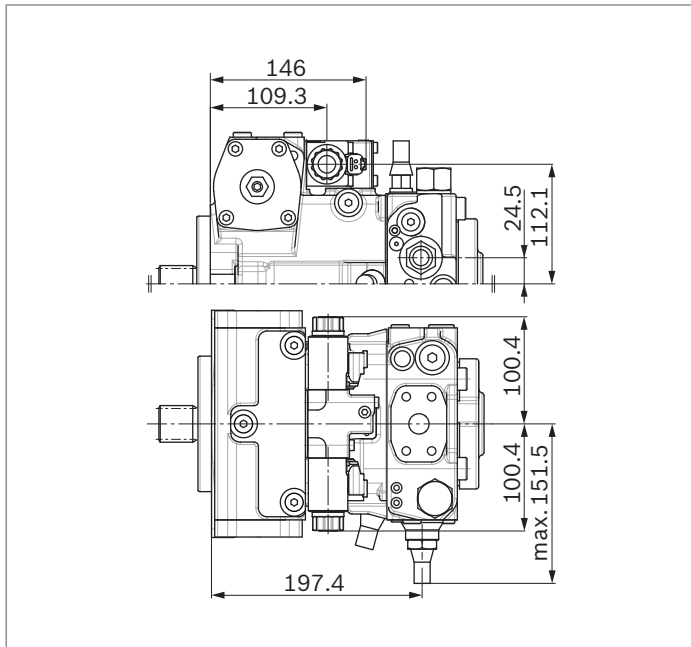

▼ **DA..3** – Mechanically adjustable with position lever

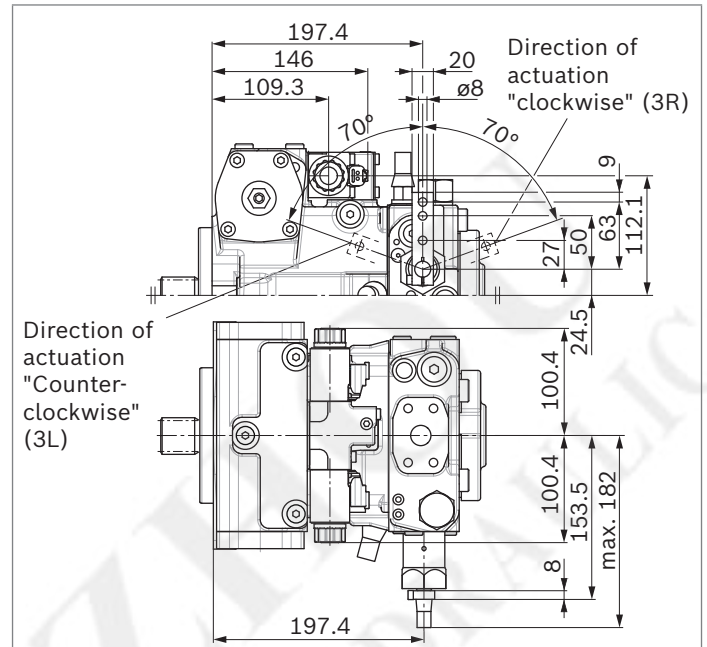

▼ **DA..7** – Fixed setting and ports for pilot control device

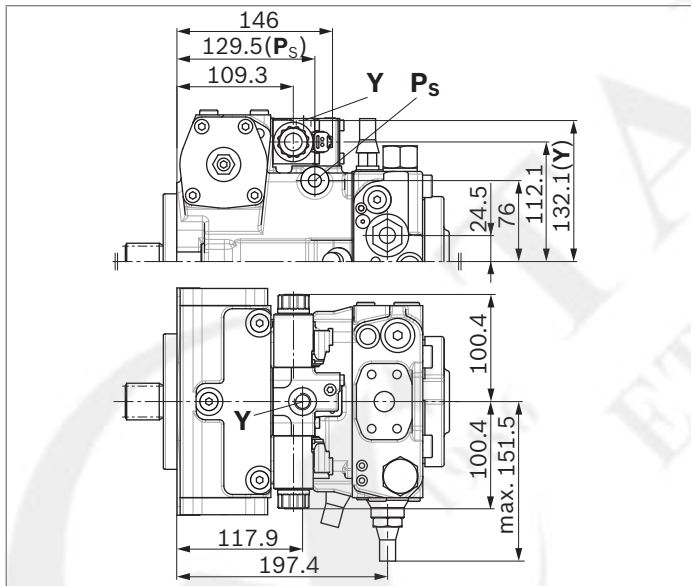

▼ **DA..8** – Fixed setting and inch valve mounted

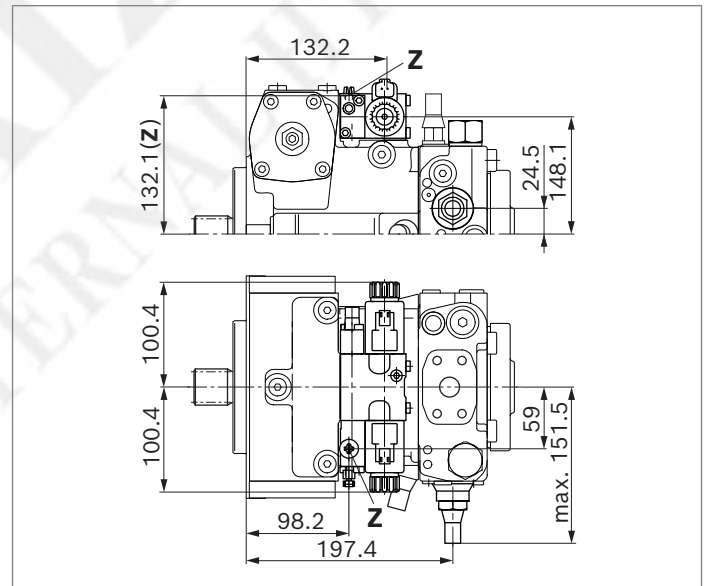

Dimensions, size 71

NV - Version without control module

Standard: SAE working port **A** and **B** top and bottom, suction port **S** bottom (02)

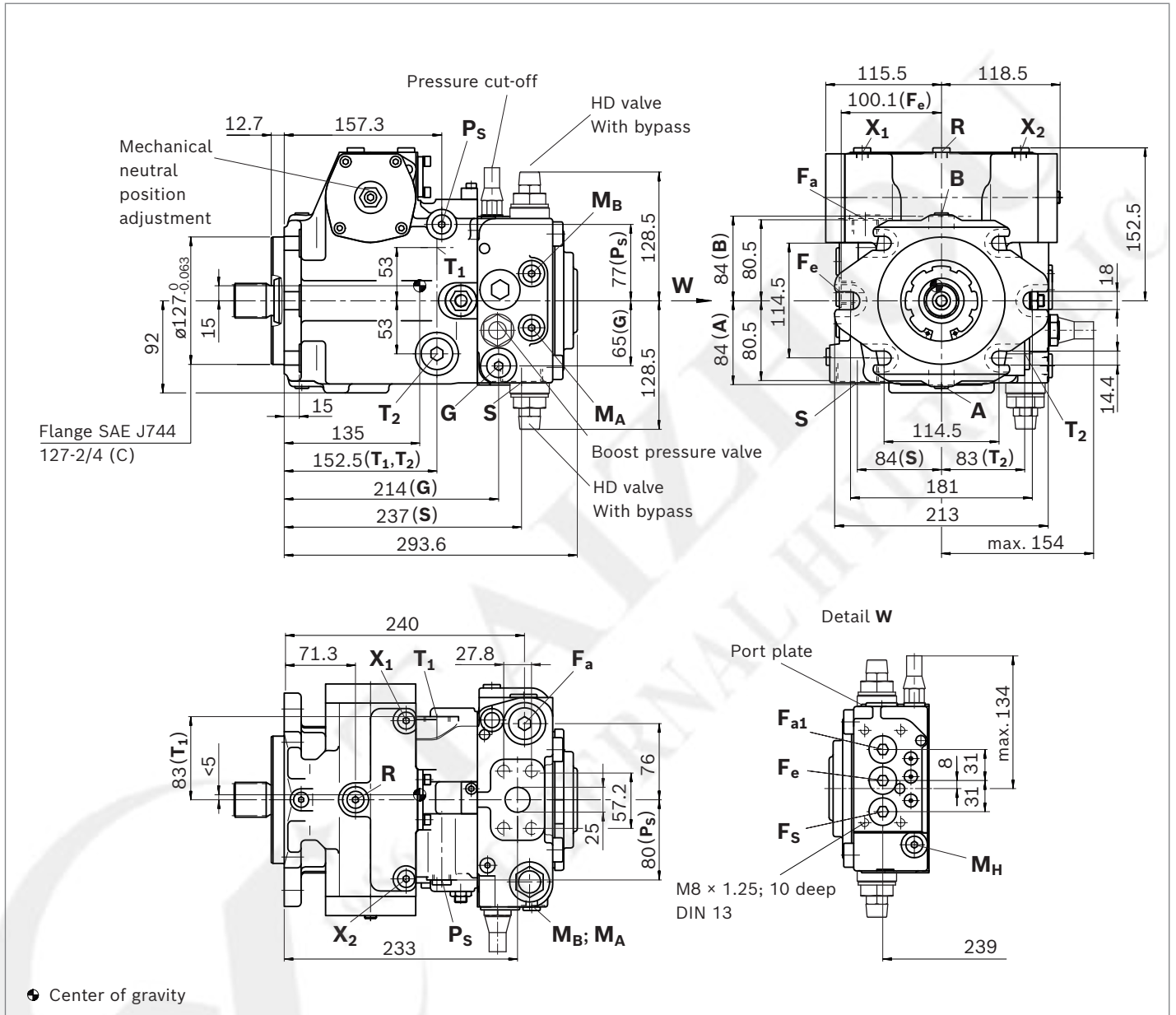

Notice

Option: SAE working port **A** and **B** top and bottom, suction port **S** top (03). Port plate (02) rotated through 180°, installation drawing on request

NV - Version without control module

Standard: SAE working port **A** and **B**, same side left, suction port **S** bottom (10)

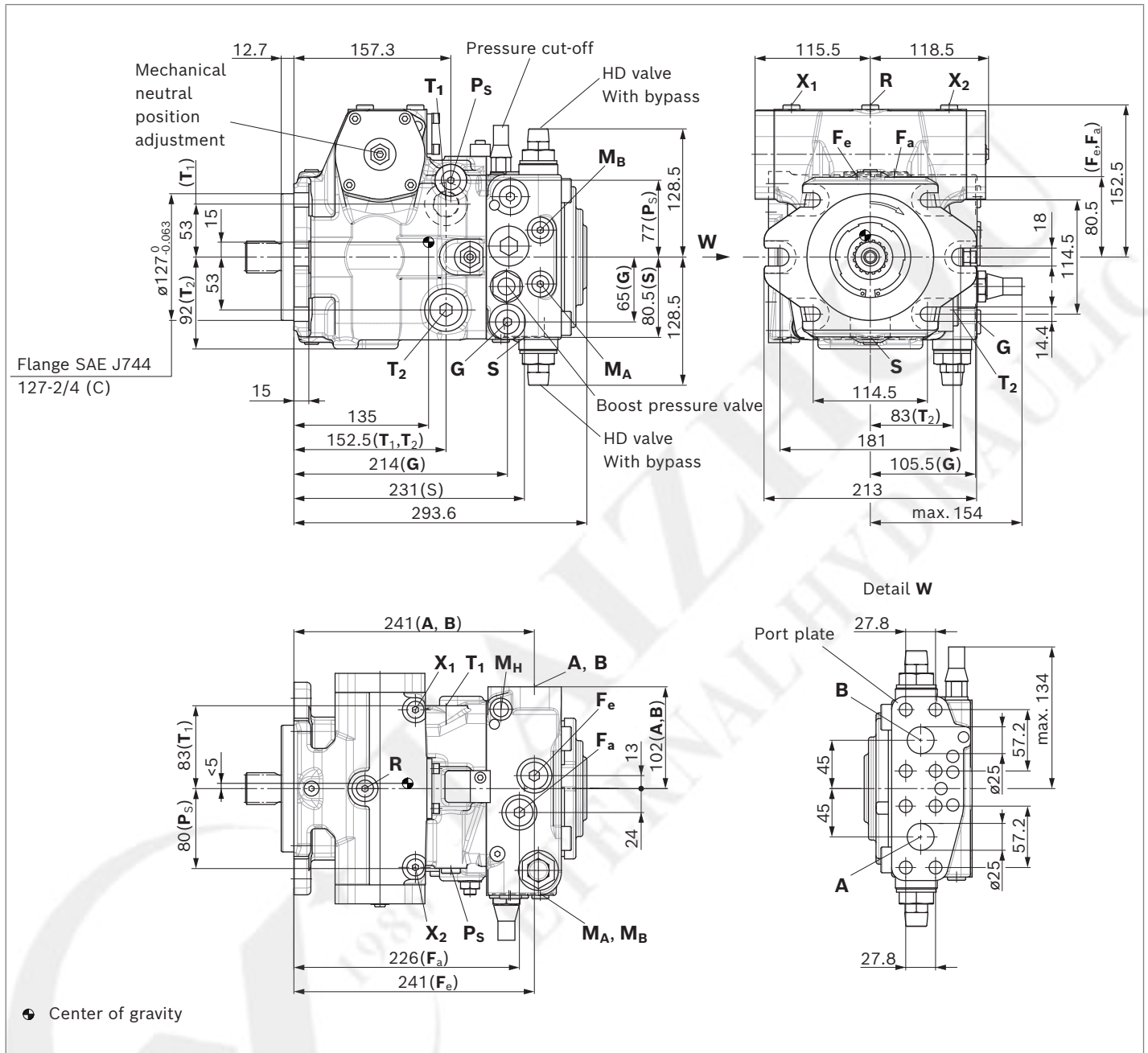

Notice

Option: SAE working port **A** and **B**, same side right, suction port **S** top (13), installation drawing on request

▼ Splined shaft DIN 5480

Z - W35×2×16×9g

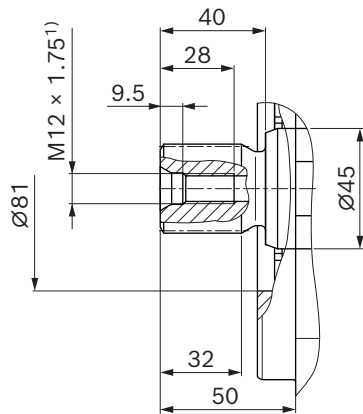

▼ Splined shaft DIN 5480

A - W40×2×18×9g

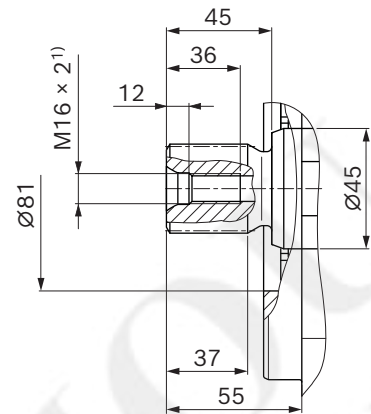

▼ Splined shaft ANSI B92.1a

S - 1 1/4 in 14T 12/24DP²

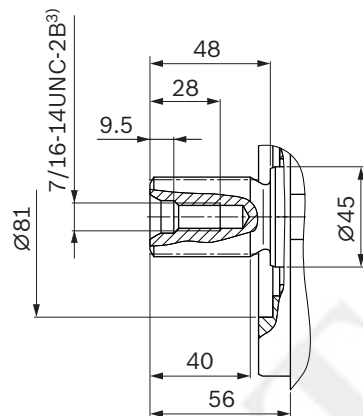

▼ Splined shaft ANSI B92.1a

T - 1 3/8 in 21T 16/32DP²

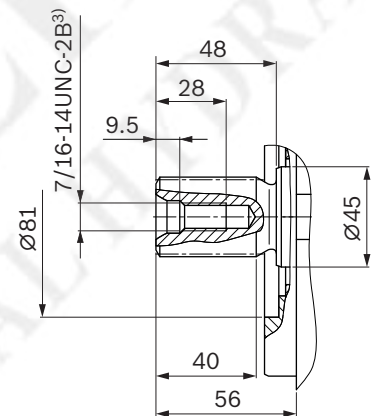

1) Center bore according to DIN 332 (thread according to DIN 13)
2) Involute spline according to ANSI B92.1a, 30° pressure angle, flat root, side fit, tolerance class 5
3) Thread according to ASME B1.1

Ports		Standard	Size	p_{\max} [bar] ⁴⁾	State ¹⁰⁾
A, B	Working port	SAEJ518 ⁵⁾	1 in	450	O
	Fastening thread	DIN 13	M12 × 1.75; 17 deep		
S	Suction port	DIN 3852 ⁸⁾	M42 × 2; 20 deep	5	O ⁶⁾
T₁	Drain port	DIN 3852 ⁸⁾	M26 × 1.5; 16 deep	3	O ⁷⁾
T₂	Drain port	DIN 3852 ⁸⁾	M26 × 1.5; 16 deep	3	X ⁷⁾
R	Air bleed port	DIN 3852 ⁸⁾	M12 × 1.5; 12 deep	3	X
X₁, X₂	Control pressure port (upstream of orifice)	DIN 3852 ⁸⁾	M12 × 1.5; 12 deep	40	X
X₁, X₂	Control pressure port (upstream of orifice, DG only)	DIN 3852 ⁸⁾	M12 × 1.5; 12 deep	40	O
X₃, X₄ ⁹⁾	Stroking chamber pressure port	DIN 3852 ⁸⁾	M12 × 1.5; 12 deep	40	X
G	Boost pressure port inlet	DIN 3852 ⁸⁾	M18 × 1.5; 12 deep	40	X
P_s	Pilot pressure port	DIN 3852 ⁸⁾	M14 × 1.5; 12 deep	40	X
P_s	Pilot pressure port (DA..7 only)	DIN 3852 ⁸⁾	M14 × 1.5; 12 deep	40	O
Y	Pilot pressure port outlet (only DA..7)	DIN 3852 ⁸⁾	M14 × 1.5; 12 deep	40	O
M_A, M_B	Measuring port pressure A, B	DIN 3852 ⁸⁾	M12 × 1.5; 12 deep	450	X
M_H	Measuring port, high pressure	DIN 3852 ⁸⁾	M12 × 1.5; 12 deep	450	X
F_a	Boost pressure port inlet	DIN 3852 ⁸⁾	M26 × 1.5; 16 deep	40	X
F_{a1} ¹⁰⁾	Boost pressure port inlet (attachment filter)	DIN 3852 ⁸⁾	M22 × 1.5; 14 deep	40	X
F_e ¹⁰⁾	Boost pressure port outlet	DIN 3852 ⁸⁾	M22 × 1.5; 14 deep	40	X
F_s ¹⁰⁾	Line from filter to suction port (cold start)	DIN 3852 ⁸⁾	M22 × 1.5; 14 deep	40	X
Y₁, Y₂	Pilot pressure port (pilot signal HD only)	DIN 3852 ⁸⁾	M14 × 1.5; 8 deep	40	O
Z	Pilot pressure port (inch signal only DA..8)	DIN 3852 ⁸⁾	M10 × 1; 12 deep	80	X

4) Depending on the application, momentary pressure peaks can occur. Keep this in mind when selecting measuring devices and fittings.

5) Only dimensions according to SAE J518, metric fastening thread is a deviation from the standard.

6) Plugged for external boost pressure supply.

7) Depending on installation position, **T₁** or **T₂** must be connected (see also installation instructions on page 98).

8) The countersink can be deeper than specified in the standard. Ports designed for straight stud ends according to EN ISO 9974-2 type E

9) Optional, see page 88

10) The diameter of the countersink deviates from the standard. (For details, see page 91, dimensions of the countersinks)

11) O = Must be connected (plugged on delivery)
X = Plugged (in normal operation)

▼ **HD** – Proportional control, hydraulic, pilot-pressure related

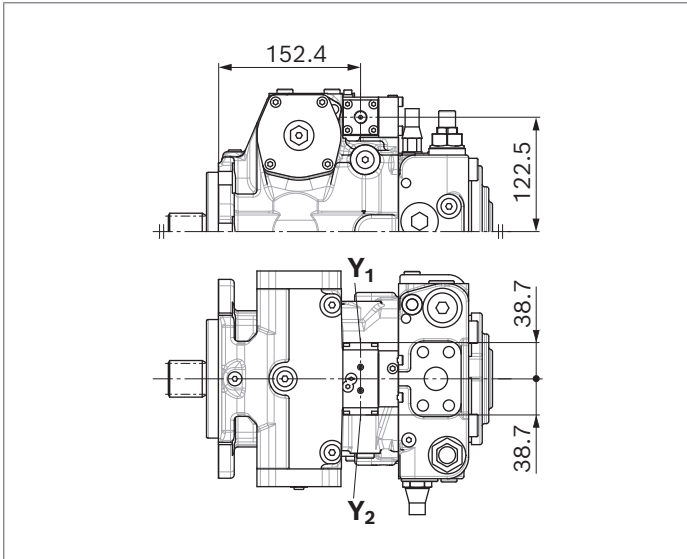

▼ **HW** – Proportional control, hydraulic, mechanical servo

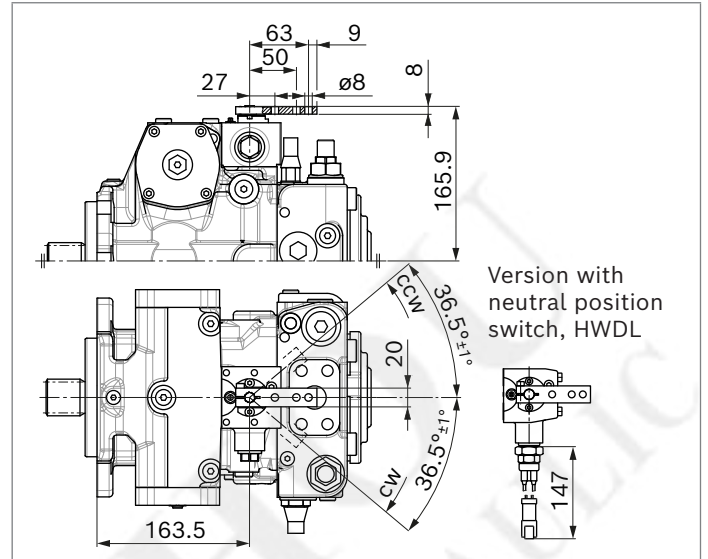

▼ **EP** – Proportional control, electric

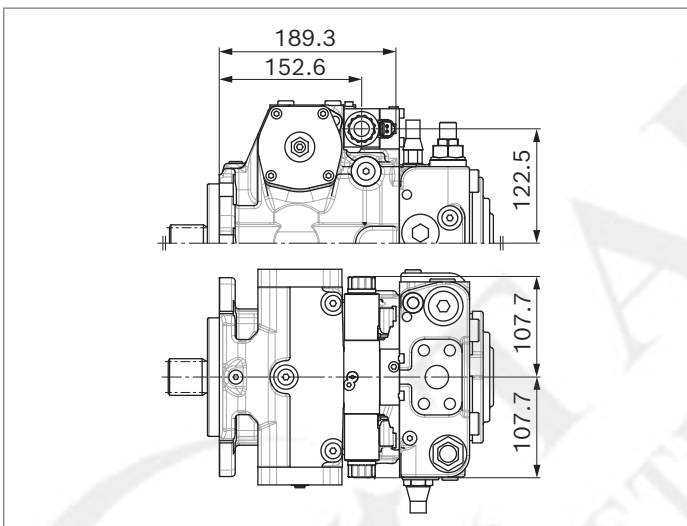

▼ **EZ** – Two-point control, electric

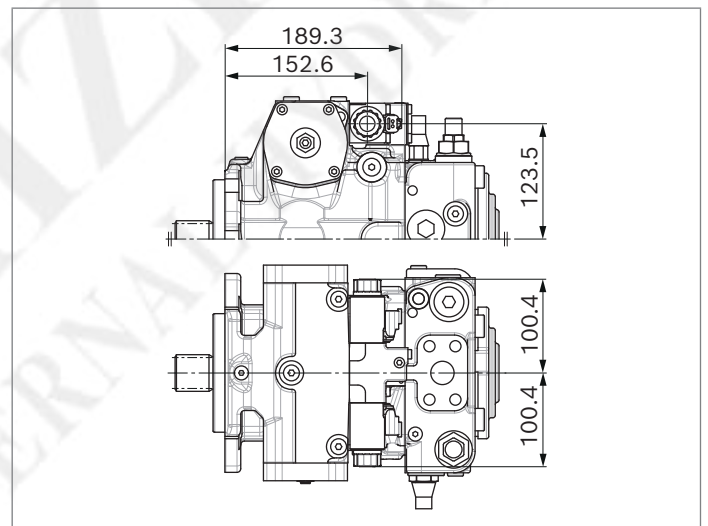

▼ **DG** – Hydraulic control, direct operated

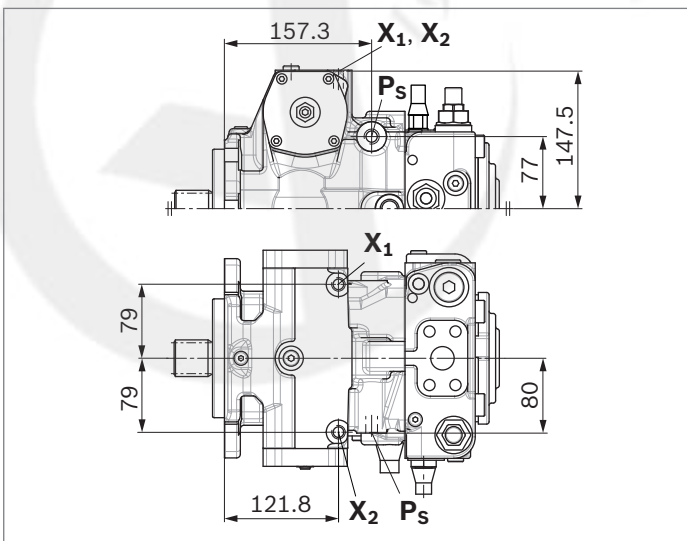

DA control valve

▼ **DA..2** – Fixed setting

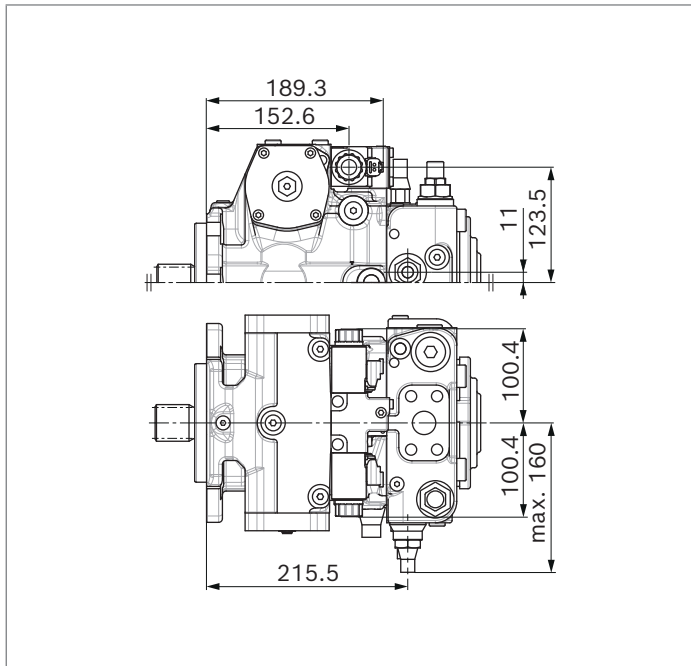

▼ **DA..3** – Mechanically adjustable with position lever

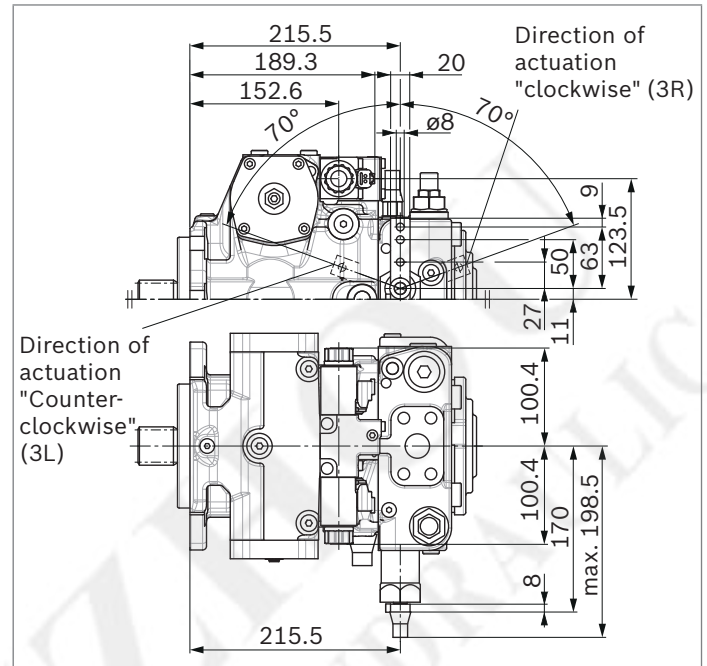

▼ **DA..7** – Fixed setting and ports for pilot control device

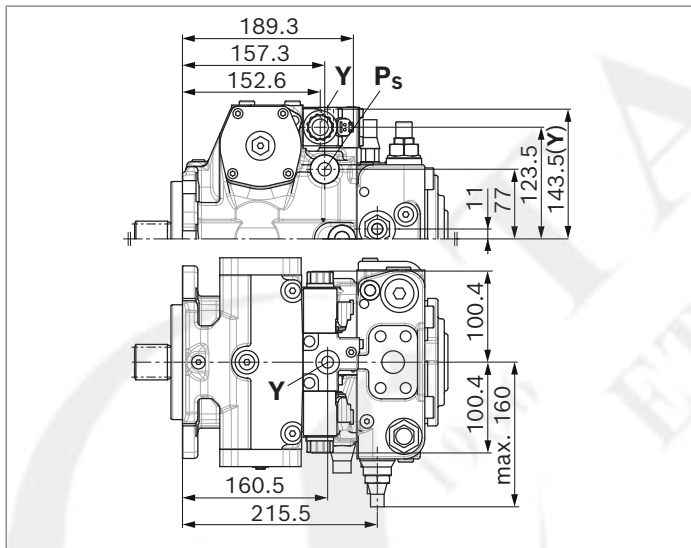

▼ **DA..8** – Fixed setting and inch valve mounted

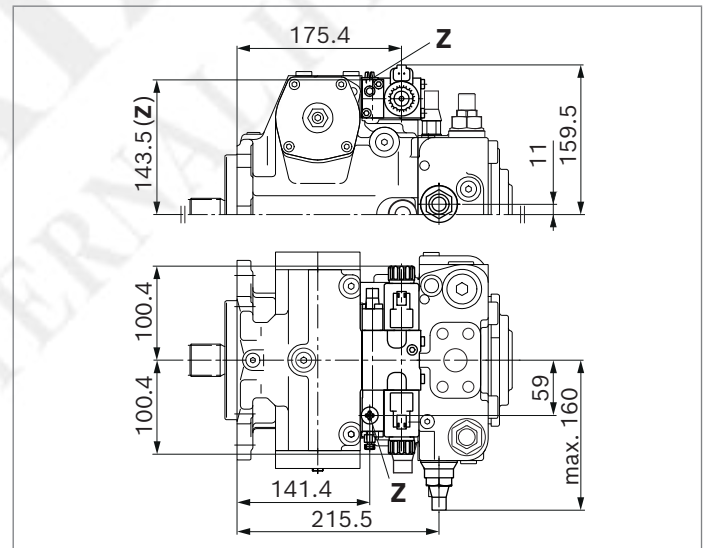

Dimensions, size 90

NV - Version without control module

Standard: SAE working port **A** and **B** top and bottom, suction port **S** bottom (02)

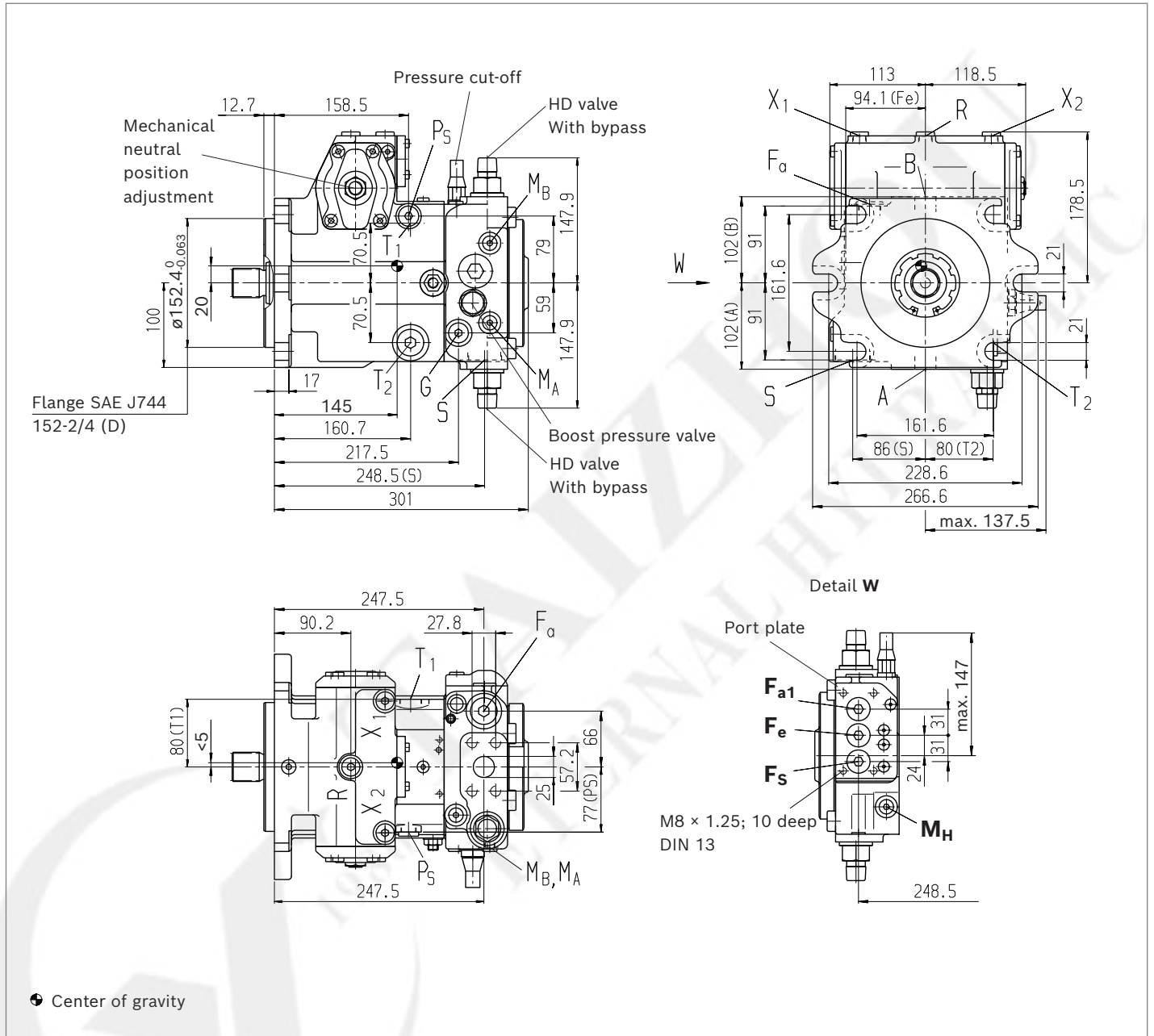

Notice

Option: SAE working port **A** and **B** top and bottom, suction port **S** top (03). Port plate (02) rotated through 180°, installation drawing on request

▼ Splined shaft DIN 5480

Z - W35×2×16×9g

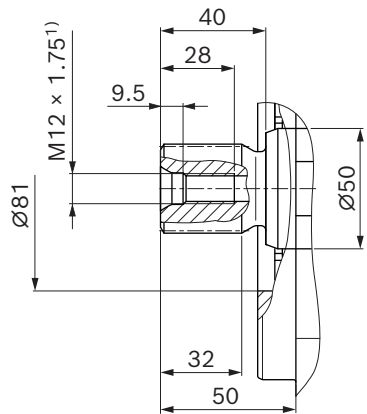

▼ Splined shaft DIN 5480

A - W45×2×21×9g

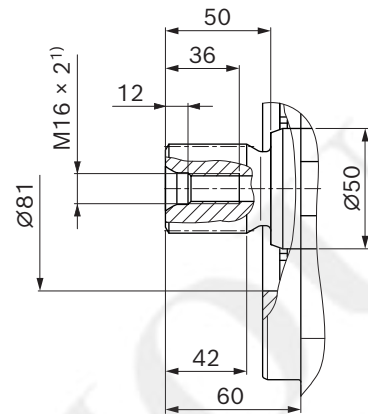

▼ Splined shaft ANSI B92.1a

S - 1 3/4 in 13T 8/16DP²⁾

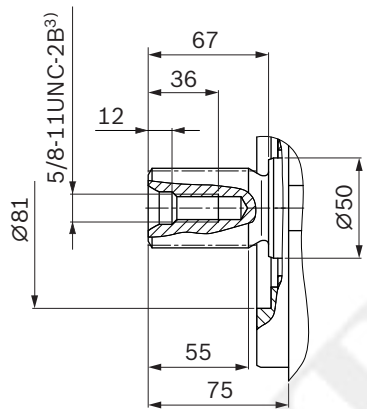

▼ Splined shaft ANSI B92.1a

U - 1 1/4 in 14T 12/24DP²⁾

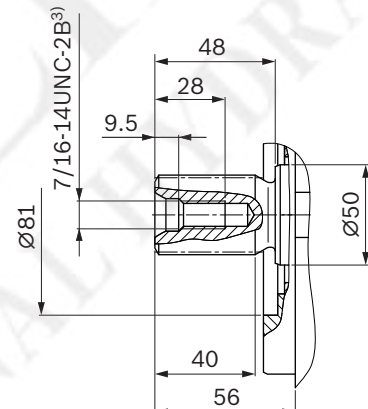

- 1) Center bore according to DIN 332 (thread according to DIN 13)
- 2) Involute spline according to ANSI B92.1a, 30° pressure angle, flat root, side fit, tolerance class 5
- 3) Thread according to ASME B1.1

Ports		Standard	Size	p_{max} [bar] ⁴⁾	State ¹⁰⁾
A, B	Working port	SAEJ518 ⁵⁾	1 in	450	O
	Fastening thread	DIN 13	M12 × 1.75; 17 deep		
S	Suction port	DIN 3852 ⁸⁾	M42 × 2; 20 deep	5	O ⁶⁾
T₁	Drain port	DIN 3852 ⁸⁾	M26 × 1.5; 16 deep	3	O ⁷⁾
T₂	Drain port	DIN 3852 ⁸⁾	M26 × 1.5; 16 deep	3	X ⁷⁾
R	Air bleed port	DIN 3852 ⁸⁾	M16 × 1.5; 12 deep	3	X
X₁, X₂	Control pressure port (upstream of orifice)	DIN 3852 ⁸⁾	M16 × 1.5; 12 deep	40	X
X₁, X₂	Control pressure port (upstream of orifice, DG only)	DIN 3852 ⁸⁾	M16 × 1.5; 12 deep	40	O
X₃, X₄ ⁹⁾	Stroking chamber pressure port	DIN 3852 ⁸⁾	M12 × 1.5; 12 deep	40	X
G	Boost pressure port inlet	DIN 3852 ⁸⁾	M18 × 1.5; 12 deep	40	X
P_s	Pilot pressure port	DIN 3852 ⁸⁾	M18 × 1.5; 12 deep	40	X
P_s	Pilot pressure port (DA..7 only)	DIN 3852 ⁸⁾	M18 × 1.5; 12 deep	40	O
Y	Pilot pressure port outlet (only DA..7)	DIN 3852 ⁸⁾	M18 × 1.5; 12 deep	40	O
M_A, M_B	Measuring port pressure A, B	DIN 3852 ⁸⁾	M12 × 1.5; 12 deep	450	X
M_H	Measuring port, high pressure	DIN 3852 ⁸⁾	M12 × 1.5; 12 deep	450	X
F_a	Boost pressure port inlet	DIN 3852 ⁸⁾	M26 × 1.5; 16 deep	40	X
F_{a1} ¹⁰⁾	Boost pressure port inlet (attachment filter)	DIN 3852 ⁸⁾	M22 × 1.5; 14 deep	40	X
F_e ¹⁰⁾	Boost pressure port outlet	DIN 3852 ⁸⁾	M22 × 1.5; 14 deep	40	X
F_s ¹⁰⁾	Line from filter to suction port (cold start)	DIN 3852 ⁸⁾	M22 × 1.5; 14 deep	40	X
Y₁, Y₂	Pilot pressure port (pilot signal HD only)	DIN 3852 ⁸⁾	M14 × 1.5; 12 deep	40	O
Z	Pilot pressure port (inch signal only DA..8)	DIN 3852 ⁸⁾	M10 × 1; 8 deep	80	X

4) Depending on the application, momentary pressure peaks can occur. Keep this in mind when selecting measuring devices and fittings.

5) Only dimensions according to SAE J518, metric fastening thread is a deviation from the standard.

6) Plugged for external boost pressure supply.

7) Depending on installation position, **T₁** or **T₂** must be connected (see also installation instructions on page 98).

8) The countersink can be deeper than specified in the standard. Ports designed for straight stud ends according to EN ISO 9974-2 type E

9) Optional, see page 88

10) The diameter of the countersink deviates from the standard. (For details, see page 91, dimensions of the countersinks)

11) O = Must be connected (plugged on delivery)
X = Plugged (in normal operation)

▼ **HD** – Proportional control, hydraulic, pilot-pressure related

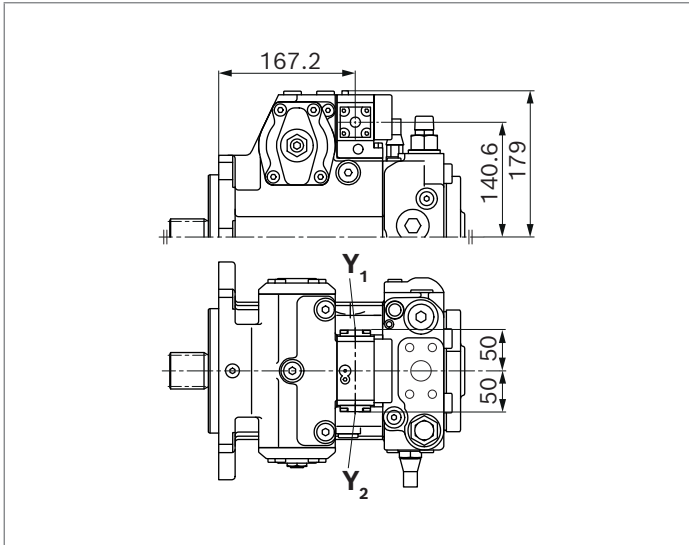

▼ **HW** – Proportional control, hydraulic, mechanical servo

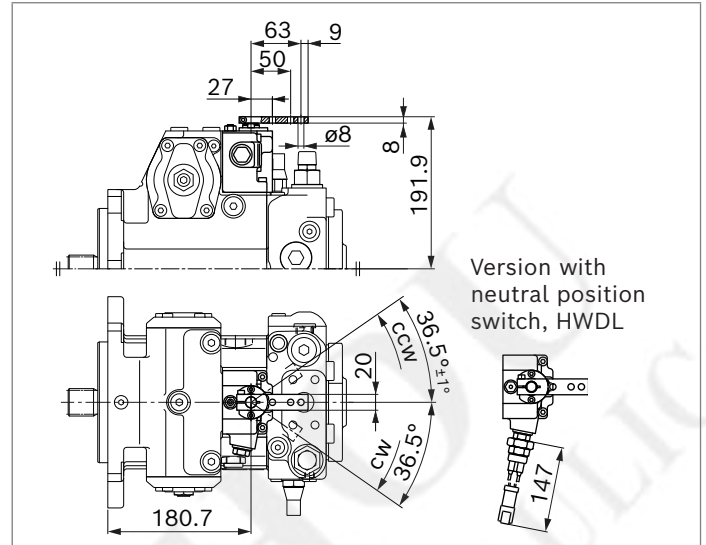

▼ **EP** – Proportional control, electric

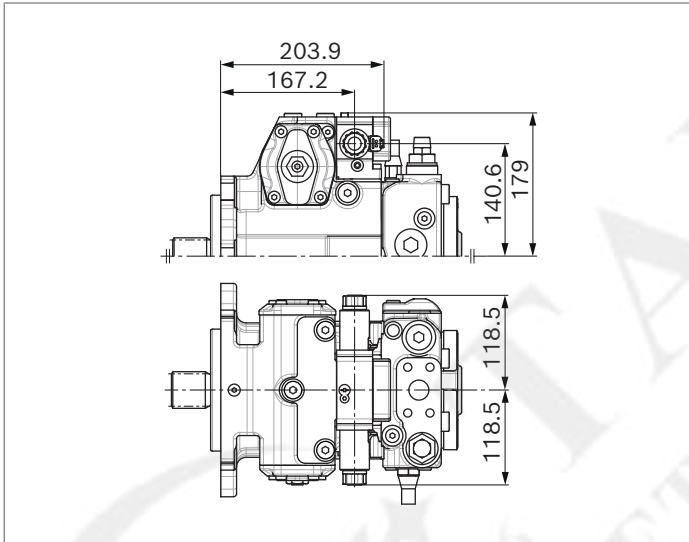

▼ **EZ** – Two-point control, electric

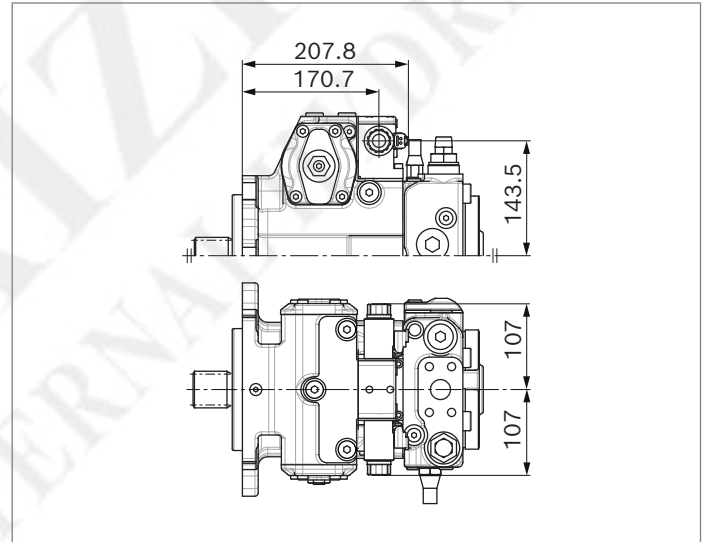

▼ **DG** – Hydraulic control, direct operated

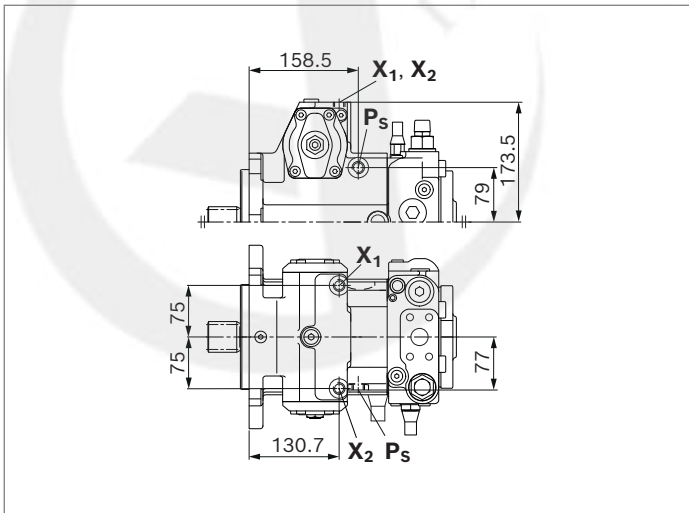

DA control valve

▼ **DA..2** – Fixed setting

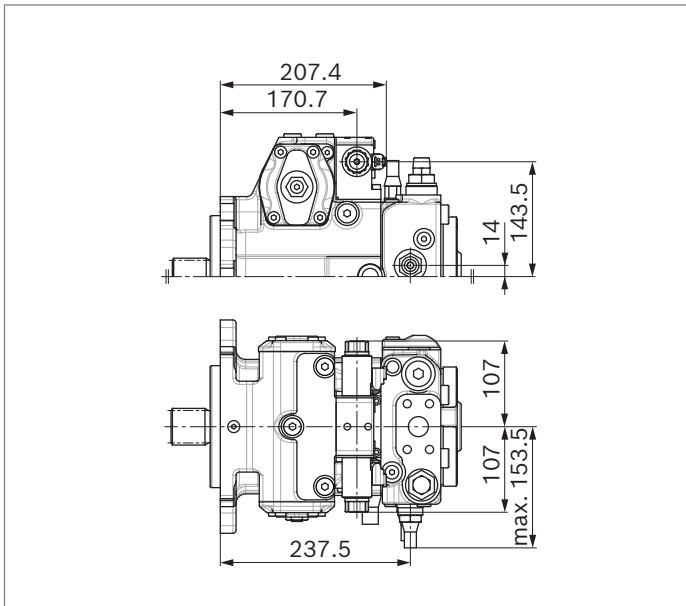

▼ **DA..3** – Mechanically adjustable with position lever

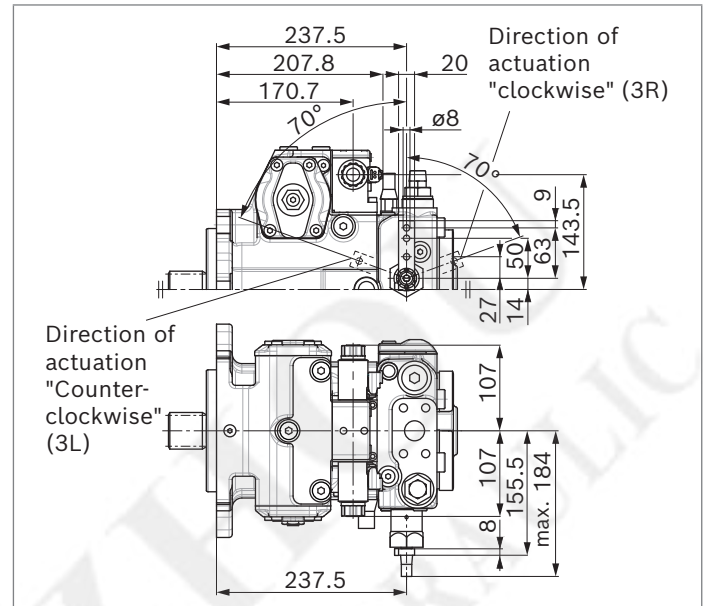

▼ **DA..7** – Fixed setting and ports for pilot control device

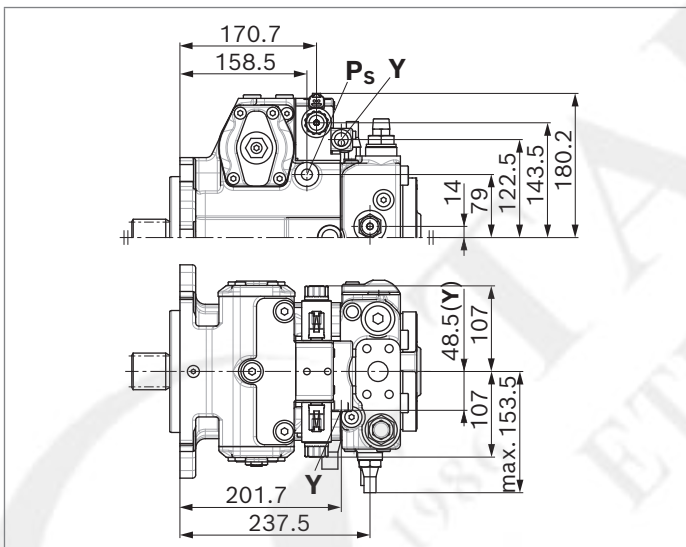

▼ **DA..8** – Fixed setting and inch valve mounted

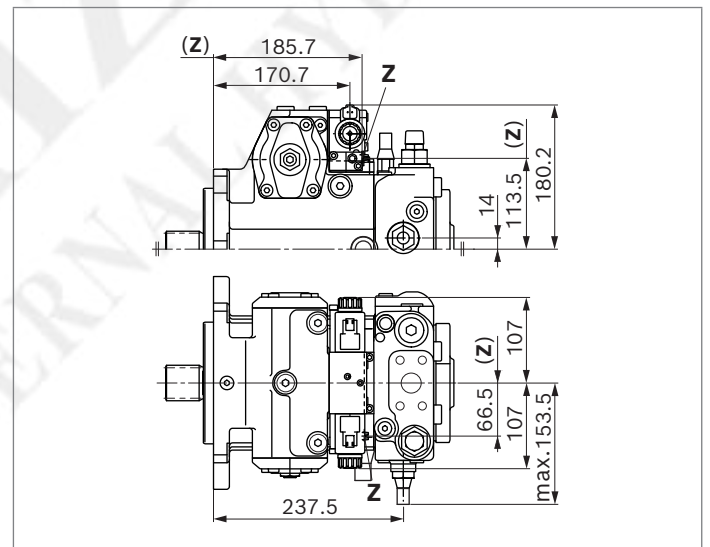

Dimensions, size 125

NV - Version without control module

Standard: SAE working port **A** and **B** top and bottom, suction port **S** bottom (02)

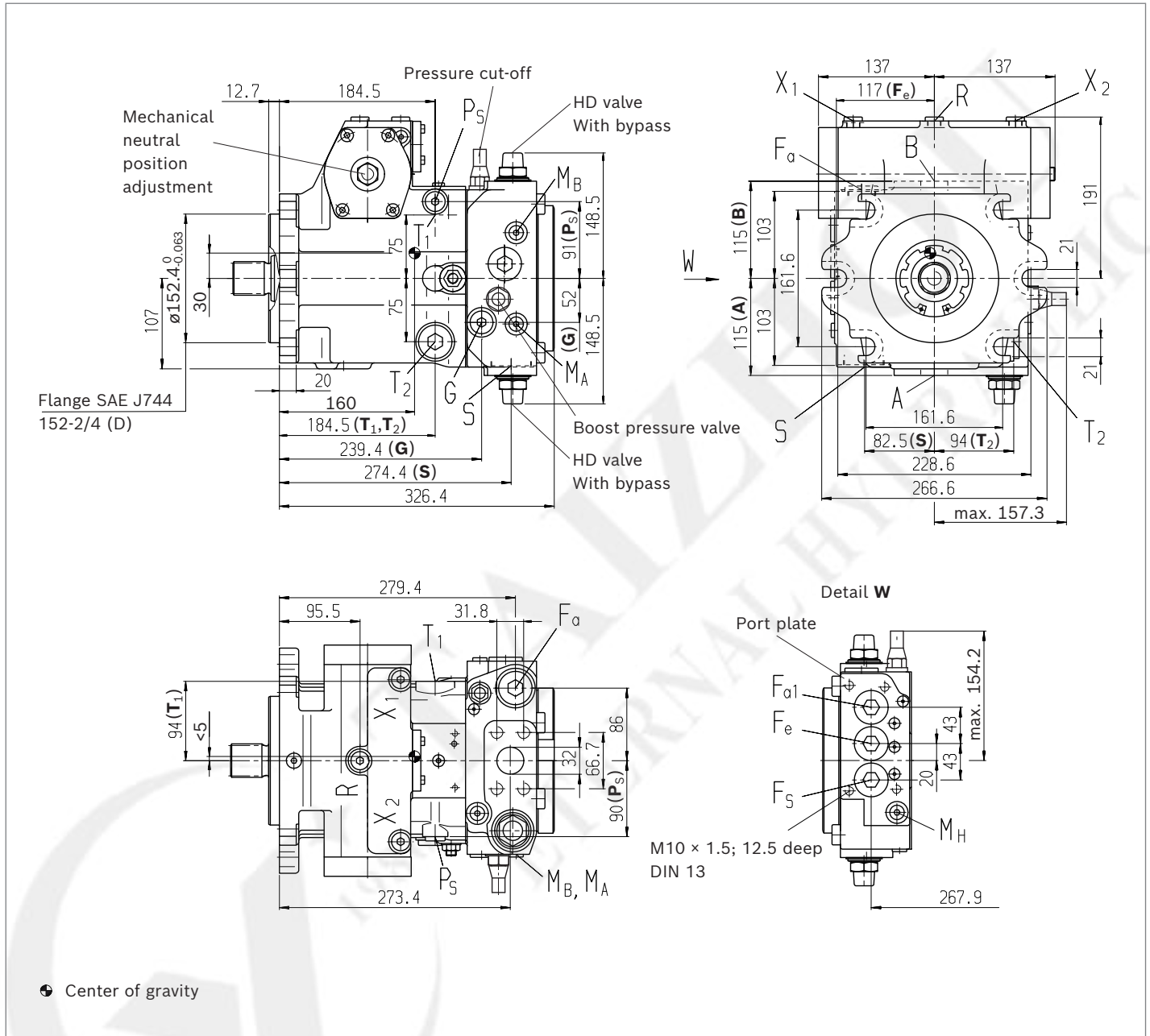

Notice

Option: SAE working port **A** and **B** top and bottom, suction port **S** top (03). Port plate (02) rotated through 180°, installation drawing on request

NV - Version without control module

Standard: SAE working port **A** and **B**, same side left, suction port **S** bottom (10)

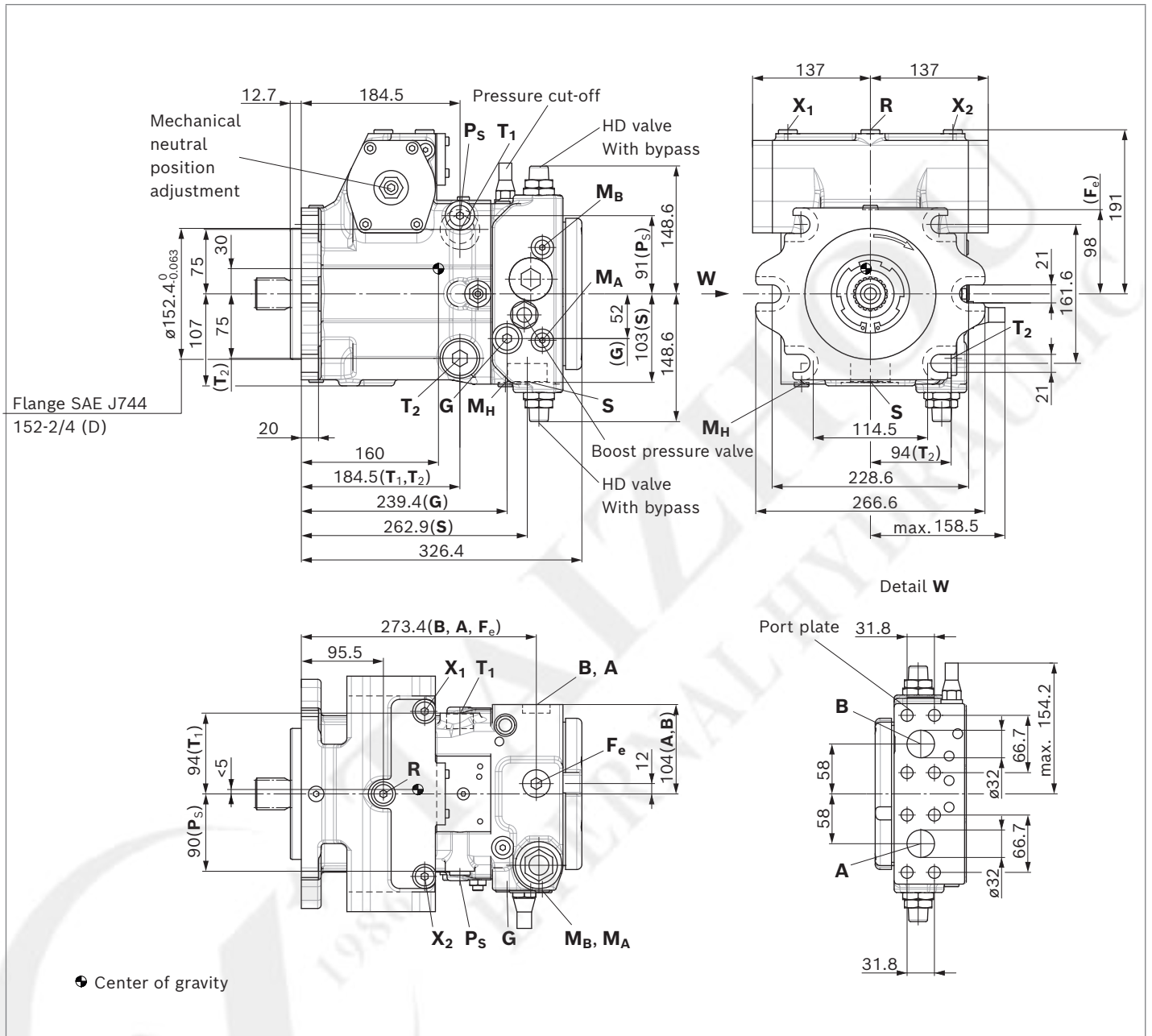

Notice

Option: SAE working port **A** and **B**, same side right, suction port **S** top (13), installation drawing on request

▼ Splined shaft DIN 5480

Z - W40×2×18×9g

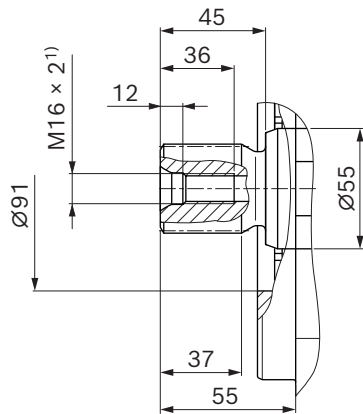

▼ Splined shaft DIN 5480

A - W45×2×21×9g

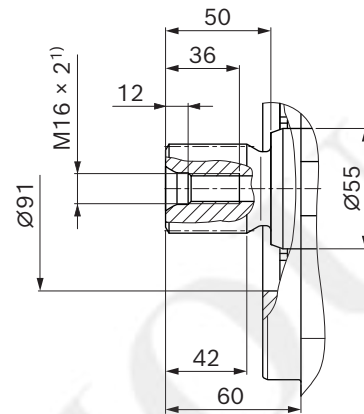

▼ Splined shaft ANSI B92.1a

S - 1 3/4 in 13T 8/16DP²⁾

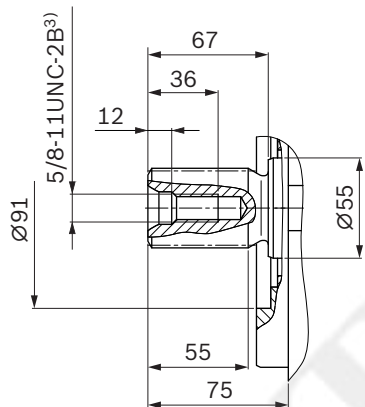

▼ Splined shaft ANSI B92.1a

T - 2 in 15T 8/16DP²⁾

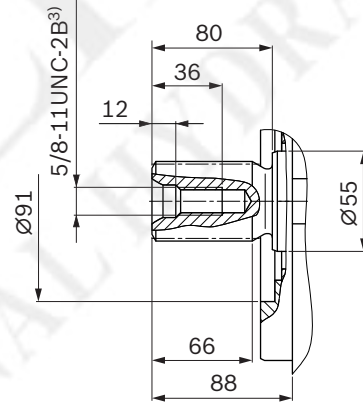

1) Center bore according to DIN 332 (thread according to DIN 13)
2) Involute spline according to ANSI B92.1a, 30° pressure angle, flat root, side fit, tolerance class 5
3) Thread according to ASME B1.1

▼ Connection table for port plate 02, 03, 10 and 13

Ports	Standard	Size	p_{max} [bar] ⁴⁾	State ¹²⁾
A, B Working port Fastening thread	SAEJ518 ⁵⁾ DIN 13	1 1/4 in M14 × 2; 19 deep	450	O
S Suction port	DIN 3852 ⁸⁾	M48 × 2; 22 deep	5	O ⁶⁾
T₁ Drain port	DIN 3852 ⁸⁾	M33 × 2; 18 deep	3	O ⁷⁾
T₂ Drain port	DIN 3852 ⁸⁾	M33 × 2; 18 deep	3	X ⁷⁾
R Air bleed port	DIN 3852 ⁸⁾	M16 × 1.5; 12 deep	3	X
X₁, X₂ Control pressure port (upstream of orifice)	DIN 3852 ⁸⁾	M16 × 1.5; 12 deep	40	X
X₁, X₂ Control pressure port (upstream of orifice, DG only)	DIN 3852 ⁸⁾	M16 × 1.5; 12 deep	40	O
X₃, X₄ ⁹⁾ Stroking chamber pressure port	DIN 3852 ⁸⁾	M12 × 1.5; 12 deep	40	X
G Boost pressure port inlet	DIN 3852 ⁸⁾	M22 × 1.5; 14 deep	40	X
P_S Pilot pressure port	DIN 3852 ⁸⁾	M18 × 1.5; 12 deep	40	X
P_S Pilot pressure port (DA..7 only)	DIN 3852 ⁸⁾	M18 × 1.5; 12 deep	40	O
Y Pilot pressure port outlet (only DA..7)	DIN 3852 ⁸⁾	M18 × 1.5; 12 deep	40	O
M_A, M_B Measuring port pressure A, B	DIN 3852 ⁸⁾	M12 × 1.5; 12 deep	450	X
M_H Measuring port, high pressure	DIN 3852 ⁸⁾	M12 × 1.5; 12 deep	450	X
F_a Boost pressure port inlet	DIN 3852 ⁸⁾	M33 × 2; 18 deep	40	X
F_{a1} ¹⁰⁾ Boost pressure port inlet (attachment filter)	DIN 3852 ⁸⁾	M33 × 2; 18 deep	40	X
F_e ¹⁰⁾ Boost pressure port outlet	DIN 3852 ⁸⁾	M33 × 2; 18 deep	40	X
F_S ¹⁰⁾ Line from filter to suction port (cold start)	DIN 3852 ⁸⁾	M33 × 2; 18 deep	40	X
Y₁, Y₂ Pilot pressure port (pilot signal HD only)	DIN 3852 ⁸⁾	M14 × 1.5; 12 deep	40	O
Z Pilot pressure port (inch signal only DA..8)	DIN 3852 ⁸⁾	M10 × 1; 8 deep	80	X

▼ Connection table for port plate 22

Ports	Standard	Size	p_{max} [bar] ⁴⁾	State ¹²⁾
A, B Working port Fastening thread	SAEJ518 ⁵⁾ DIN 13	1 1/4 in M14 × 2; 19 deep	450	O
S Suction port	ISO 6149 ¹¹⁾	M48 × 2; 22 deep	5	O ⁶⁾
T₁ Drain port	ISO 6149 ¹¹⁾	M33 × 2; 19 deep	3	O ⁷⁾
T₂ Drain port	ISO 6149 ¹¹⁾	M33 × 2; 19 deep	3	X ⁷⁾
R Air bleed port	ISO 6149 ¹¹⁾	M14 × 1.5; 11.5 deep	3	X
X₁, X₂ Control pressure port (upstream of orifice)	ISO 6149 ¹¹⁾	M14 × 1.5; 11.5 deep	40	X
G Boost pressure port inlet	ISO 6149 ¹¹⁾	M22 × 1.5; 15.5 deep	40	X
P_S Pilot pressure port	ISO 6149 ¹¹⁾	M18 × 1.5; 14.5 deep	40	X
M_A, M_B Measuring port pressure A, B	ISO 6149 ¹¹⁾	M14 × 1.5; 12 deep	450	X
F_a Boost pressure port inlet	ISO 6149 ¹¹⁾	M33 × 2; 19 deep	40	X
F_{a1} ¹⁰⁾ Boost pressure port inlet (attachment filter)	DIN 3852 ⁸⁾	M33 × 2; 18 deep	40	X
F_e ¹⁰⁾ Boost pressure port outlet	DIN 3852 ⁸⁾	M33 × 2; 18 deep	40	X
F_S ¹⁰⁾ Line from filter to suction port (cold start)	DIN 3852 ⁸⁾	M33 × 2; 18 deep	40	X

4) Depending on the application, momentary pressure peaks can occur. Keep this in mind when selecting measuring devices and fittings.

5) Only dimensions according to SAE J518, metric fastening thread is a deviation from the standard.

6) Plugged for external boost pressure supply.

7) Depending on installation position, **T₁** or **T₂** must be connected (see also installation instructions on page 98).

8) The countersink can be deeper than specified in the standard. Ports designed for straight stud ends according to EN ISO 9974-2 type E

9) Optional, see page 88

10) The diameter of the countersink deviates from the standard. (For details, see page 91, dimensions of the countersinks)

11) The countersink may be deeper than specified in the standard. Ports designed for straight stud ends according to EN ISO 6149-2

12) O = Must be connected (plugged on delivery)

X = Plugged (in normal operation)

▼ **HD** – Proportional control, hydraulic, pilot-pressure related

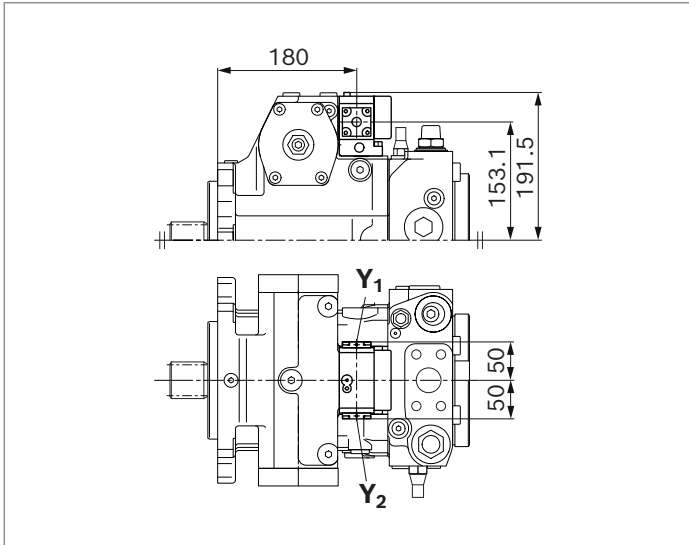

▼ **HW** – Proportional control, hydraulic, mechanical servo

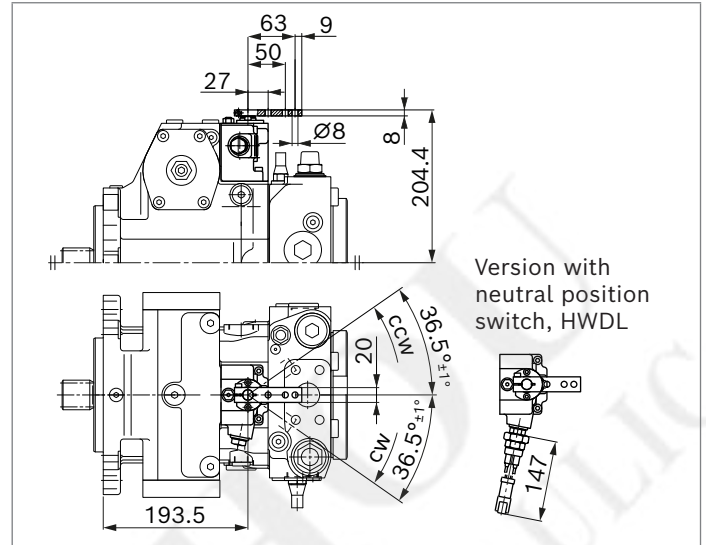

▼ **EP** – Proportional control, electric

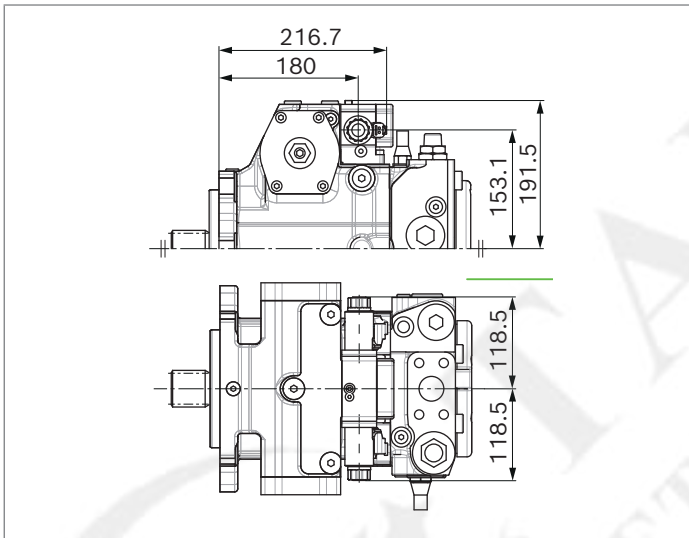

▼ **EZ** – Two-point control, electric

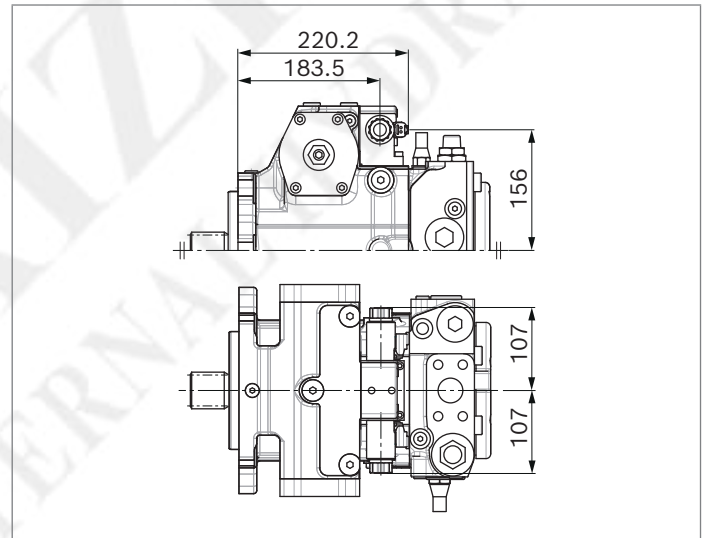

▼ **DG** – Hydraulic control, direct operated

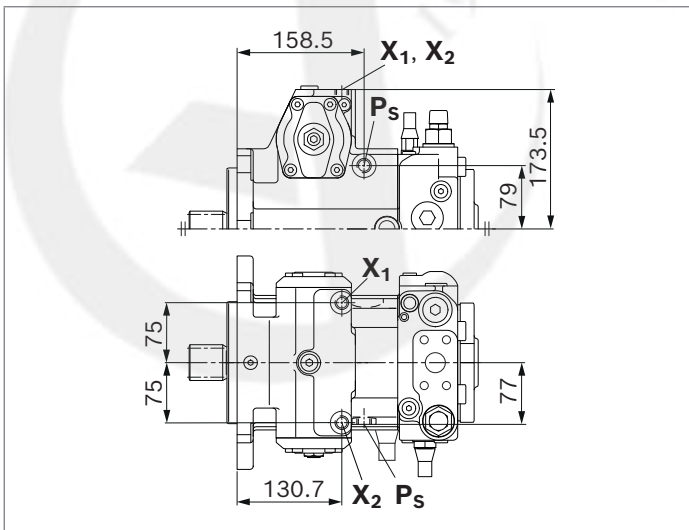

▼ **ET** – Electric control, direct operated, two DRE5

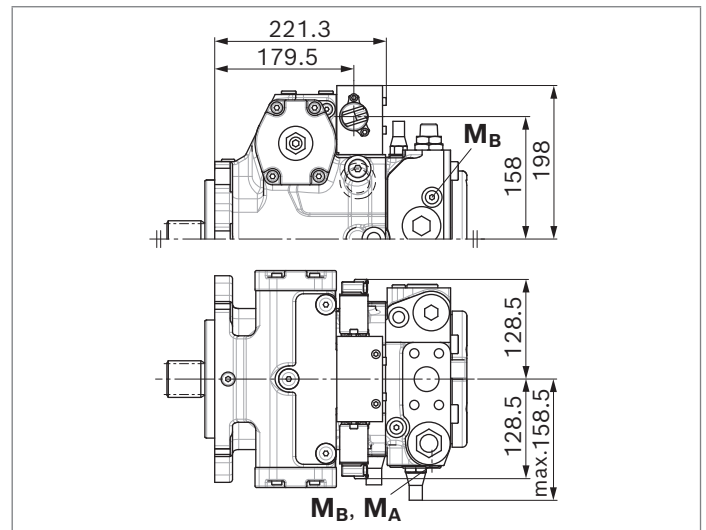

▼ **BT** – BODAS electronic control

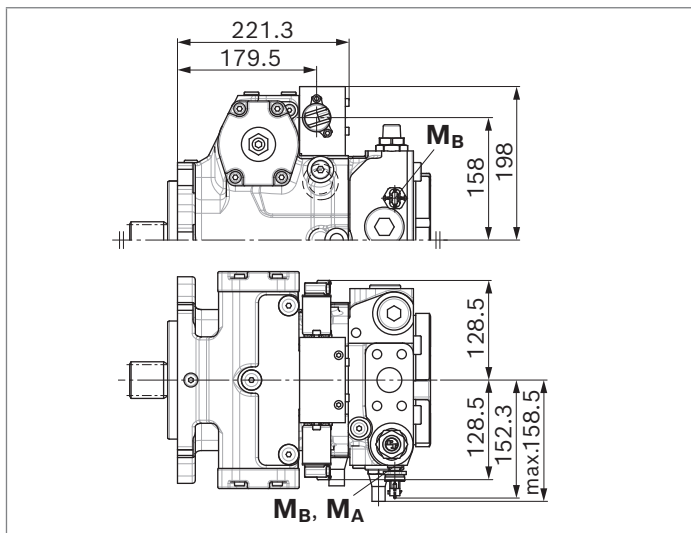

DA control valve

▼ **DA..2** – Fixed setting

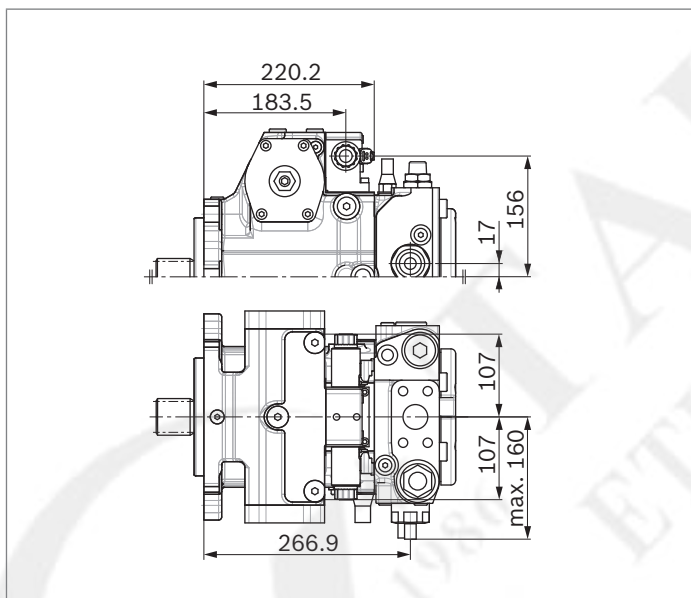

▼ **DA..3** – Mechanically adjustable with position lever

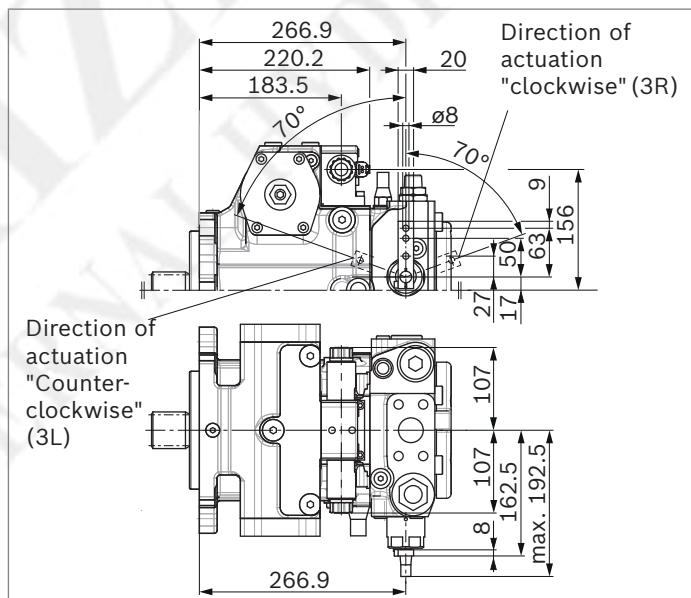

▼ DA..7 – Fixed setting and ports for pilot control device

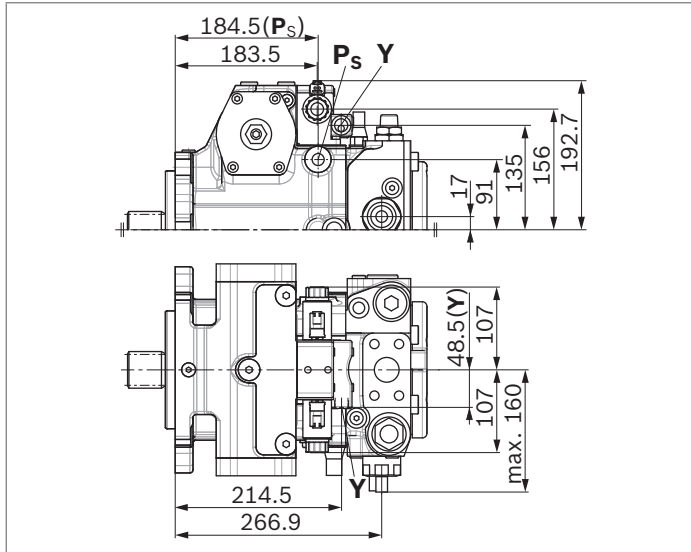

▼ DA..8 – Fixed setting and inch valve mounted

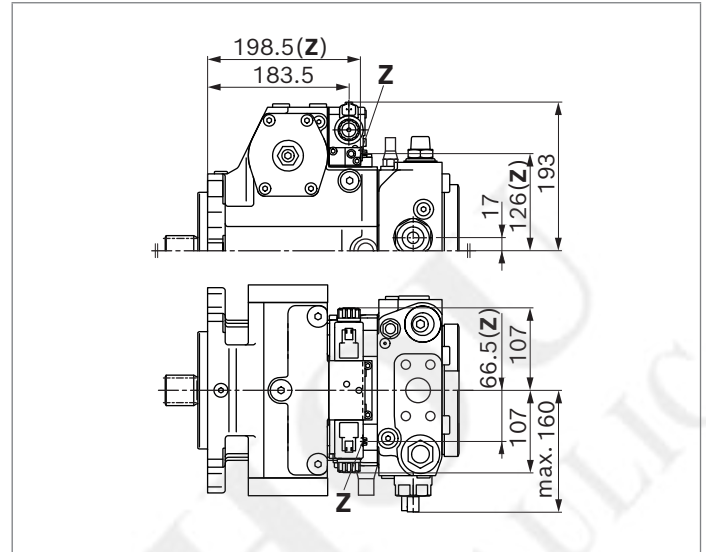

Dimensions, size 180

NV - Version without control module

Standard: SAE working port **A** and **B** top and bottom, suction port **S** bottom (02)

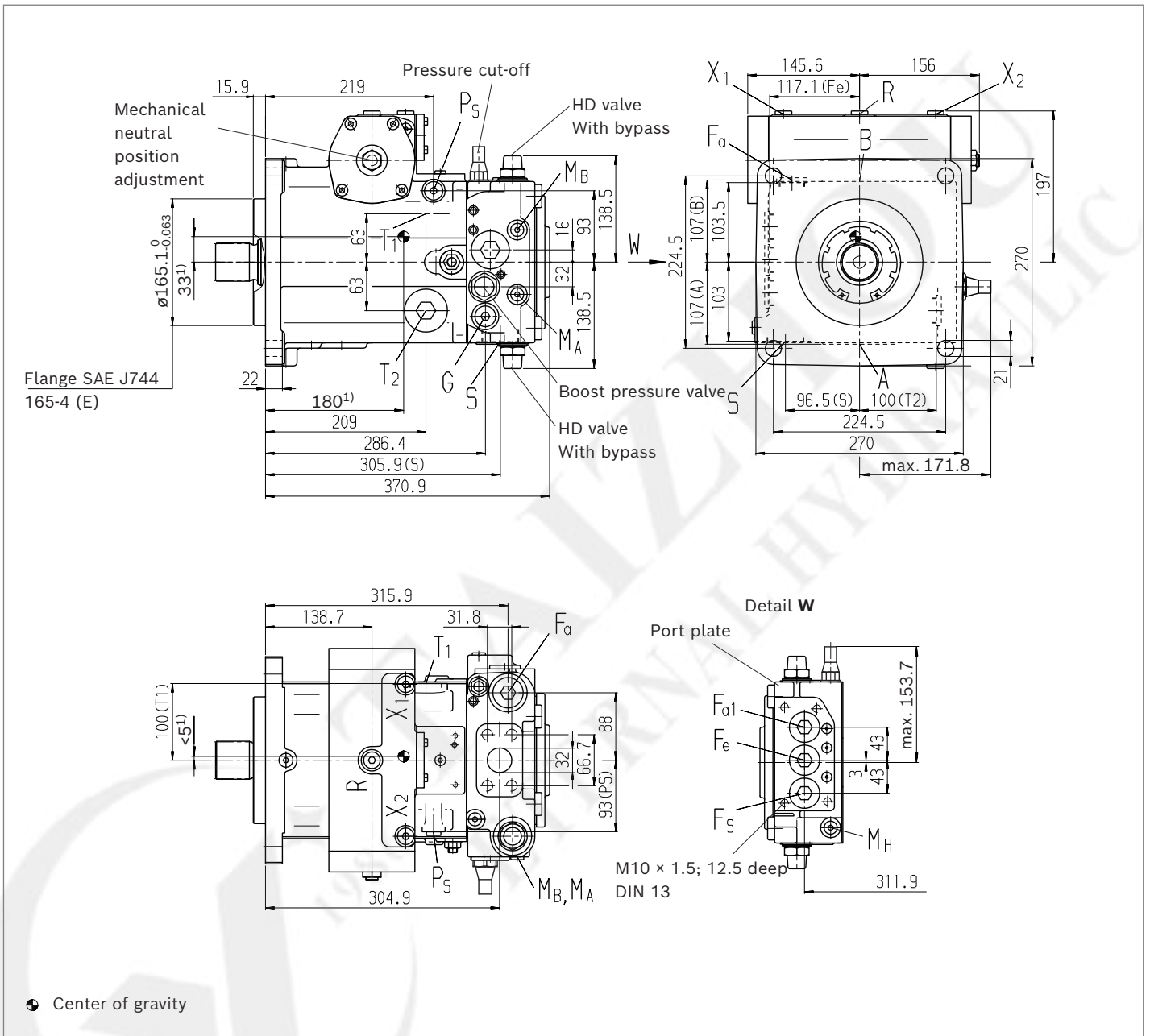

Notice

Option: SAE working port **A** and **B** top and bottom, suction port **S** top (03). Port plate (02) rotated through 180°, installation drawing on request

1) Center of gravity

▼ Splined shaft DIN 5480

Z - W50×2×24×9g

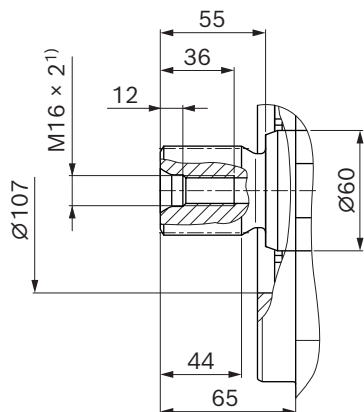

▼ Splined shaft ANSI B92.1a

S - 1 3/4 in 13T 8/16DP²⁾

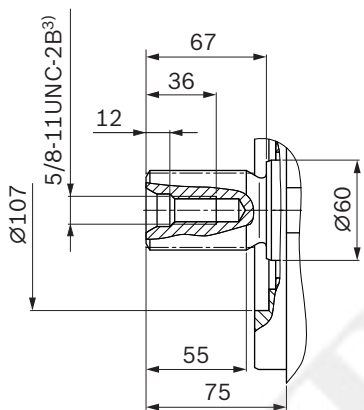

▼ Splined shaft ANSI B92.1a

T - 2 1/4 in 17T 8/16DP²⁾

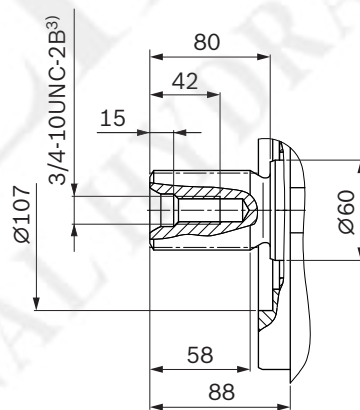

1) Involute spline according to ANSI B92.1a, 30° pressure angle, flat root, side fit, tolerance class 5
2) Center bore according to DIN 332 (thread according to DIN 13)
3) Thread according to ASME B1.1

Ports		Standard	Size	p_{max} [bar] ⁴⁾	State ¹⁰⁾
A, B	Working port	SAEJ518 ⁵⁾	1 1/4 in	450	O
	Fastening thread	DIN 13	M14 × 2; 19 deep		
S	Suction port	DIN 3852 ⁸⁾	M48 × 2; 22 deep	5	O ⁶⁾
T₁	Drain port	DIN 3852 ⁸⁾	M42 × 2; 20 deep	3	O ⁷⁾
T₂	Drain port	DIN 3852 ⁸⁾	M42 × 2; 20 deep	3	X ⁷⁾
R	Air bleed port	DIN 3852 ⁸⁾	M16 × 1.5; 12 deep	3	X
X₁, X₂	Control pressure port (upstream of orifice)	DIN 3852 ⁸⁾	M16 × 1.5; 12 deep	40	X
X₁, X₂	Control pressure port (upstream of orifice, DG only)	DIN 3852 ⁸⁾	M16 × 1.5; 12 deep	40	O
X₃, X₄ ⁹⁾	Stroking chamber pressure port	DIN 3852 ⁸⁾	M12 × 1.5; 12 deep	40	X
G	Boost pressure port inlet	DIN 3852 ⁸⁾	M22 × 1.5; 14 deep	40	X
P_S	Pilot pressure port	DIN 3852 ⁸⁾	M18 × 1.5; 12 deep	40	X
P_S	Pilot pressure port (DA..7 only)	DIN 3852 ⁸⁾	M18 × 1.5; 12 deep	40	O
Y	Pilot pressure port outlet (only DA..7)	DIN 3852 ⁸⁾	M18 × 1.5; 12 deep	40	O
M_A, M_B	Measuring port pressure A, B	DIN 3852 ⁸⁾	M12 × 1.5; 12 deep	450	X
M_H	Measuring port, high pressure	DIN 3852 ⁸⁾	M12 × 1.5; 12 deep	450	X
F_a	Boost pressure port inlet	DIN 3852 ⁸⁾	M33 × 2; 18 deep	40	X
F_{a1} ¹⁰⁾	Boost pressure port inlet (attachment filter)	DIN 3852 ⁸⁾	M33 × 2; 18 deep	40	X
F_e ¹⁰⁾	Boost pressure port outlet	DIN 3852 ⁸⁾	M33 × 2; 18 deep	40	X
F_S ¹⁰⁾	Line from filter to suction port (cold start)	DIN 3852 ⁸⁾	M33 × 2; 18 deep	40	X
Y₁, Y₂	Pilot pressure port (pilot signal HD only)	DIN 3852 ⁸⁾	M14 × 1.5; 12 deep	40	O
Z	Pilot pressure port (inch signal only DA..8)	DIN 3852 ⁸⁾	M10 × 1; 8 deep	80	X

4) Depending on the application, momentary pressure peaks can occur. Keep this in mind when selecting measuring devices and fittings.

5) Only dimensions according to SAE J518, metric fastening thread is a deviation from the standard.

6) Plugged for external boost pressure supply.

7) Depending on installation position, **T₁** or **T₂** must be connected (see also installation instructions on page 98).

8) The countersink can be deeper than specified in the standard. Ports designed for straight stud ends according to EN ISO 9974-2 type E

9) Optional, see page 88

10) The diameter of the countersink deviates from the standard. (For details, see page 91, dimensions of the countersinks)

11) O = Must be connected (plugged on delivery)

X = Plugged (in normal operation)

▼ **HD** – Proportional control, hydraulic, pilot-pressure related

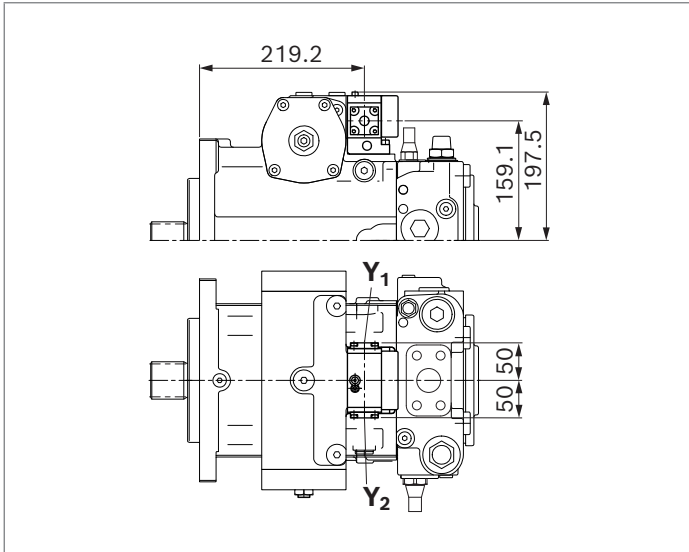

▼ **HW** – Proportional control, hydraulic, mechanical servo

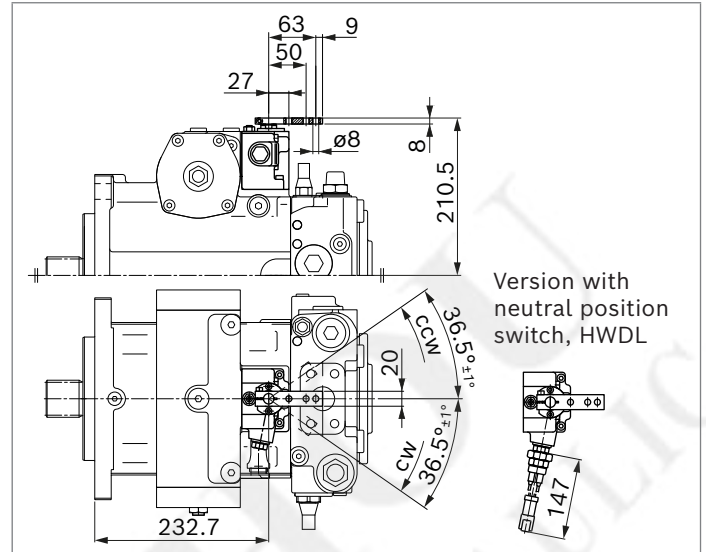

▼ **EP** – Proportional control, electric

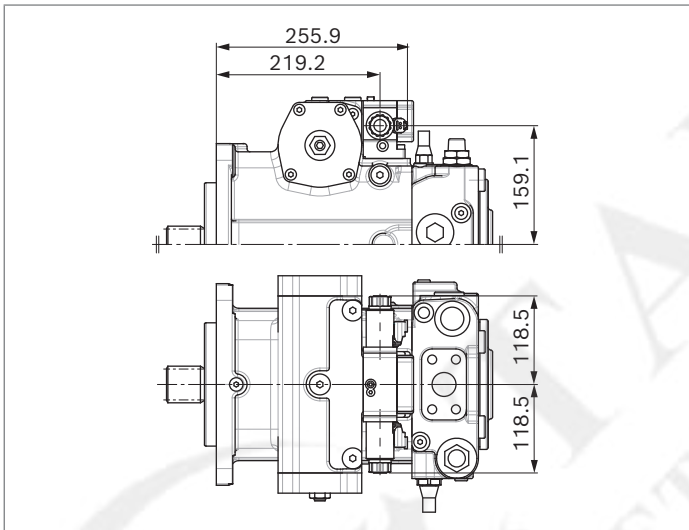

▼ **EZ** – Two-point control, electric

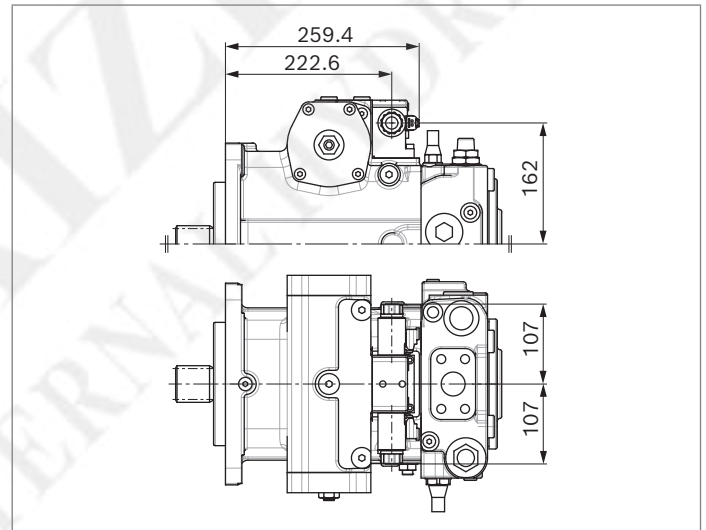

▼ **DG** – Hydraulic control, direct operated

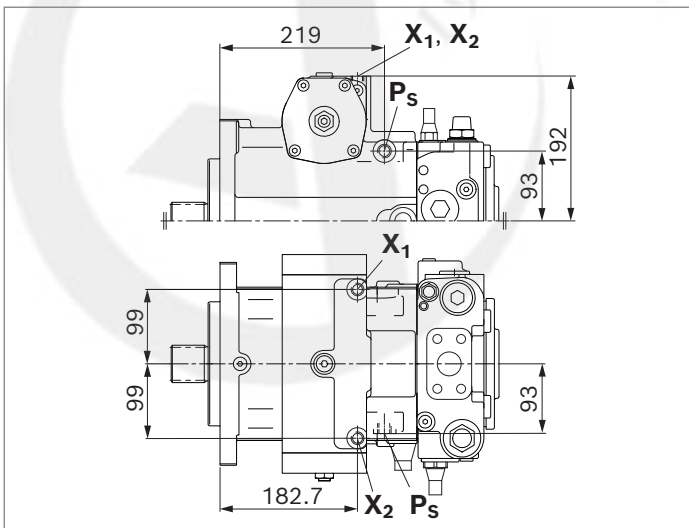

DA control valve

▼ **DA..2** – Fixed setting

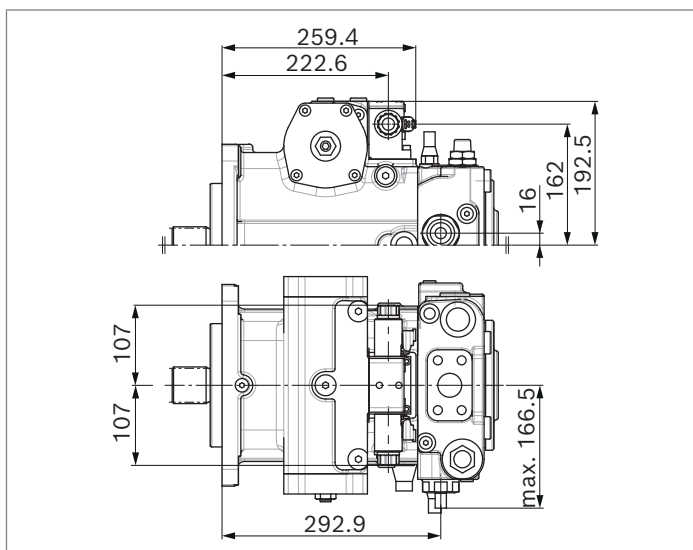

▼ **DA..7** – Fixed setting and ports for pilot control device

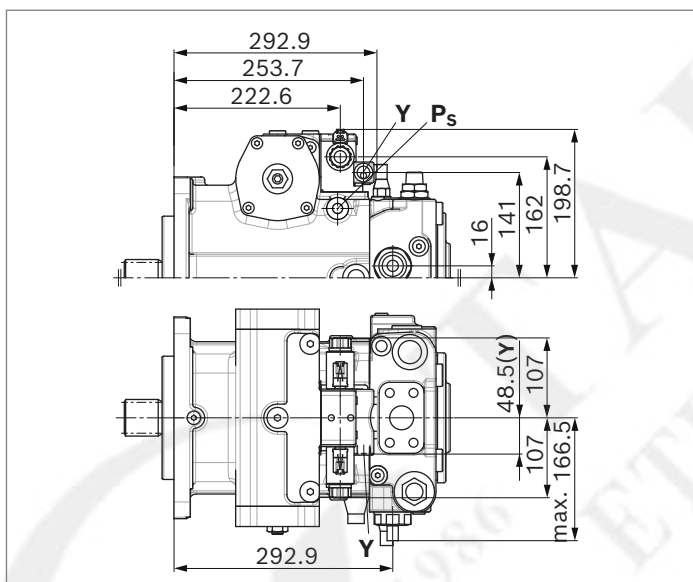

▼ **DA..8** – Fixed setting and inch valve mounted

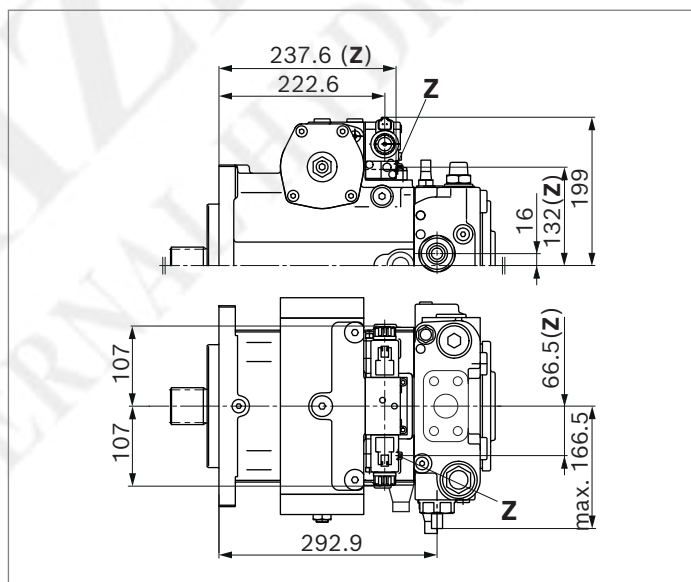

Dimensions, through drive

Flange SAE J744	Hub for splined shaft ¹⁾	28	40	56	71	90	125	180	Code
Without through drive		●	●	●	●	●	●	●	00
82-2 (A)	5/8 in 9T 16/32DP	●	●	●	●	●	●	●	01

▼ N00 (without boost pump, without through drive) / F00 (with boost pump, without through drive)

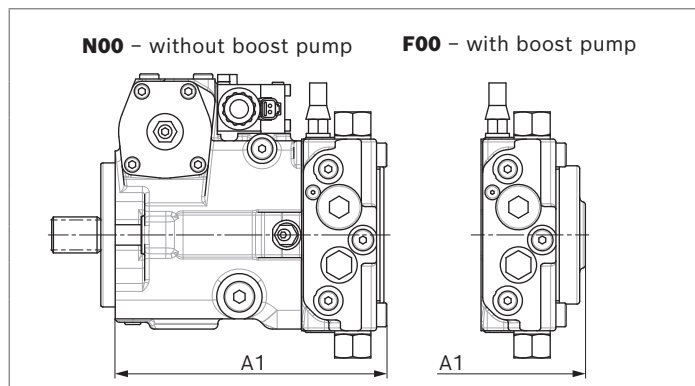

NG	A1 (N00)	A1 (F00)
28	213.9	223.4
40	220.2	235.7
56	239.4	256.4
71	279.1	293.6
90	287	301
125	320.9	326.4
180	370.9	370.9

▼ F01⁴⁾, sizes 28 to 71 (with boost pump)

Flange SAE J744: 82-2 (A)

Hub for splined shaft: 5/8 in 9T 16/32DP¹⁾

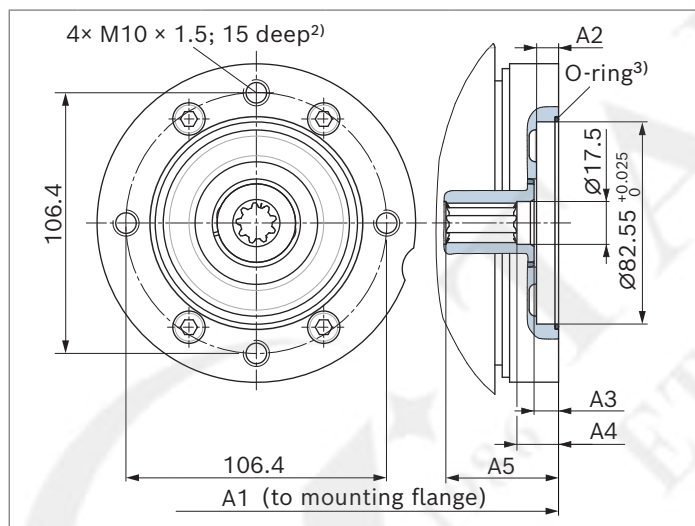

NG	A1	A2	A3	A4	A5
28	227.9	7.5	8.2	15.2	33.9
40	239.7	9	10	17	46
56	261.4	10	11	18	38.3
71	297.6	9	10	17	47.8

▼ K01⁴⁾, sizes 28 to 71 (without boost pump)

Flange SAE J744: 82-2 (A)

Hub for splined shaft: 5/8 in 9T 16/32DP¹⁾

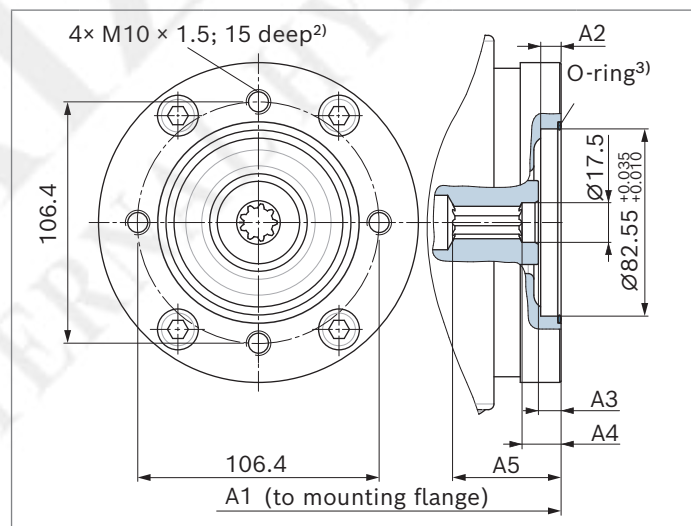

NG	A1	A2	A3	A4	A5
28	227.9	7.5	7.5	-	33.2
40	234.2	7.5	8.5	-	34.5
56	254.9	7.5	9	-	30.3
71	297.6	9	10	17.2	47.8

1) Involute spline according to ANSI B92.1a, 30° pressure angle, flat root, side fit, tolerance class 5

2) Thread according to DIN 13

3) O-ring included in the scope of delivery

4) Please state in plain text whether the 2-hole horizontal or the 2-hole vertical version is used.

Flange SAE J744	Hub for splined shaft ¹⁾	28	40	56	71	90	125	180	Code
82-2 (A)	5/8 in 9T 16/32DP ¹⁾	•	•	•	•	•	•	•	01

▼ **F01⁴⁾, size 90 (with boost pump)**

Flange SAE J744: 82-2 (A)

Hub for splined shaft: 5/8 in 9T 16/32DP¹⁾

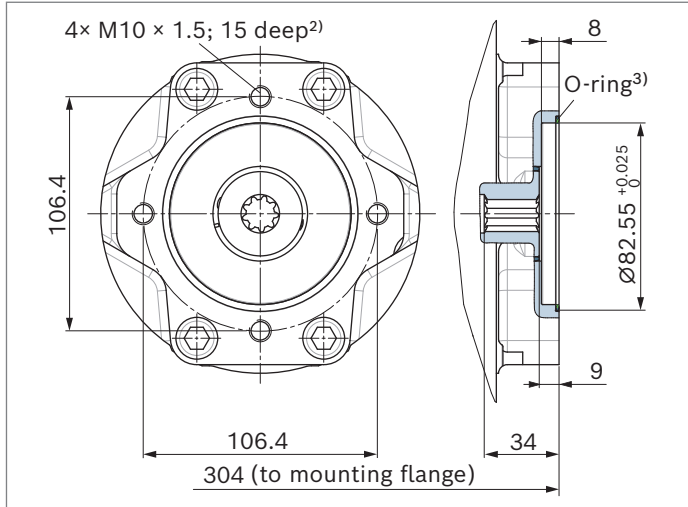

▼ **K01⁴⁾, size 90 (without boost pump)**

Flange SAE J744: 82-2 (A)

Hub for splined shaft: 5/8 in 9T 16/32DP¹⁾

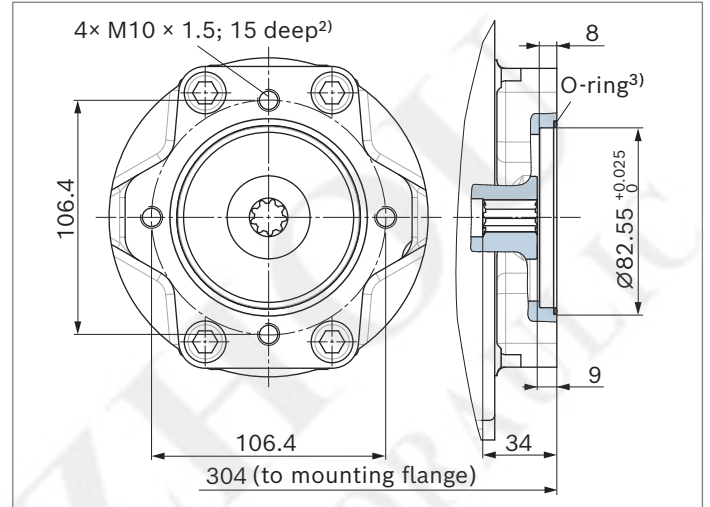

▼ **F01⁴⁾, size 125 (with boost pump)**

Flange SAE J744: 82-2 (A)

Hub for splined shaft: 5/8 in 9T 16/32DP¹⁾

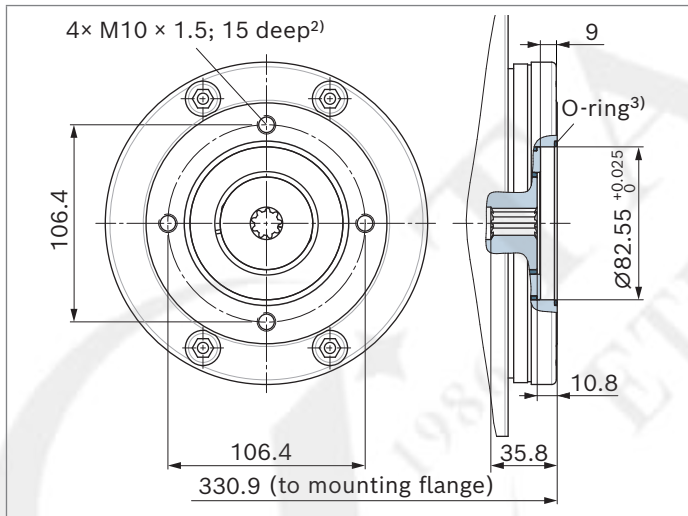

▼ **K01⁴⁾, size 125 (without boost pump)**

Flange SAE J744: 82-2 (A)

Hub for splined shaft: 5/8 in 9T 16/32DP¹⁾

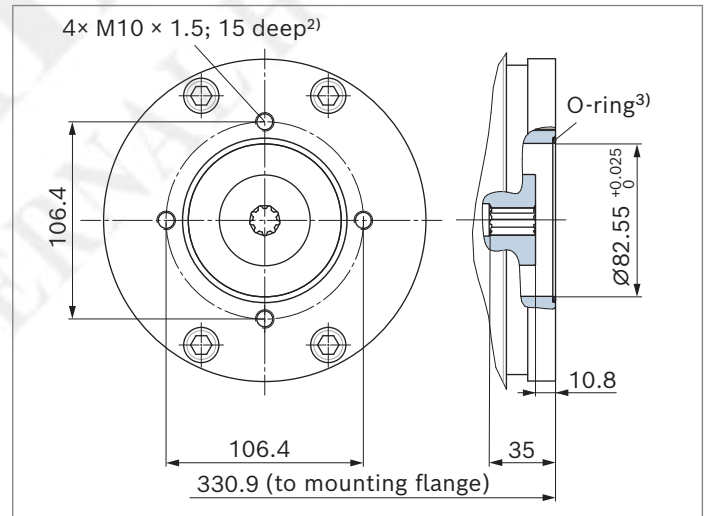

1) Involute spline according to ANSI B92.1a, 30° pressure angle, flat root, side fit, tolerance class 5

2) Thread according to DIN 13

3) O-ring included in the scope of delivery

4) Please state in plain text whether the 2-hole horizontal or the 2-hole vertical version is used.

Flange SAE J744	Hub for splined shaft ¹⁾	28	40	56	71	90	125	180	Code
82-2 (A)	5/8 in 9T 16/32DP	●	●	●	●	●	●	●	01
	3/4 in 11T 16/32DP	-	●	●	●	-	-	●	52

▼ **F01⁴⁾, size 180 (with boost pump)**

Flange SAE J744: 82-2 (A)

Hub for splined shaft: 5/8 in 9T 16/32DP¹⁾

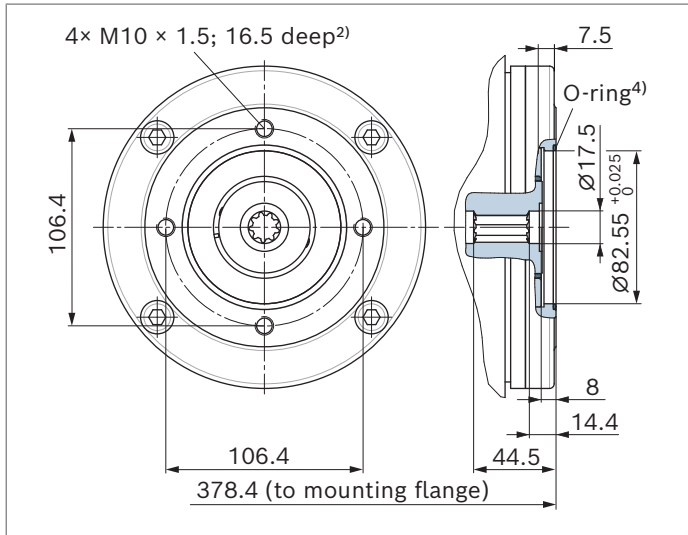

▼ **K01⁴⁾, size 180 (without boost pump)**

Flange SAE J744: 82-2 (A)

Hub for splined shaft: 5/8 in 9T 16/32DP¹⁾

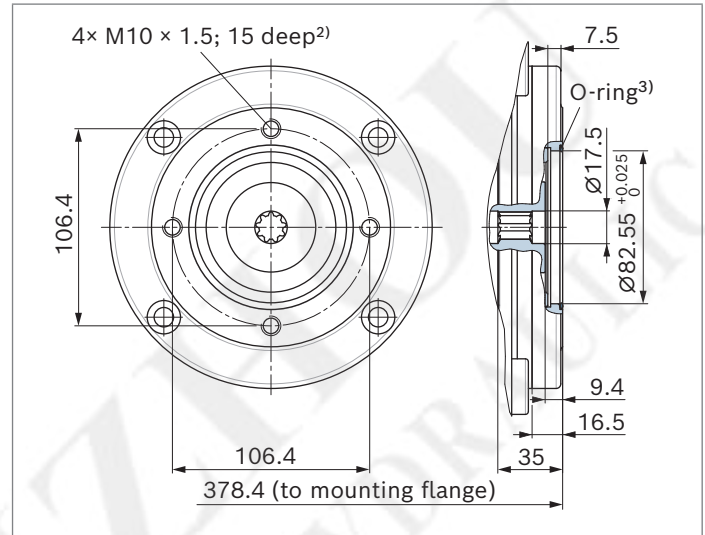

▼ **F52⁴⁾, sizes 40 to 71 (with boost pump)**

Flange SAE J744: 82-2 (A)

Hub for splined shaft: 3/4 in 11T 16/32DP¹⁾

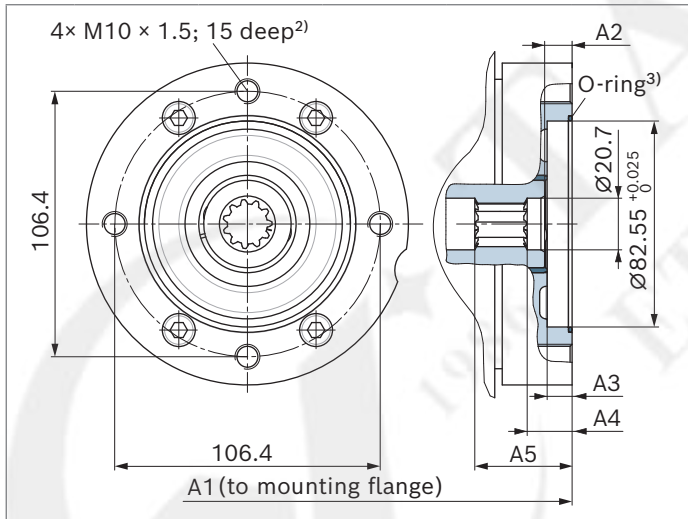

▼ **F52⁴⁾, size 180 (with boost pump)**

Flange SAE J744: 82-2 (A)

Hub for splined shaft: 3/4 in 11T 16/32DP¹⁾

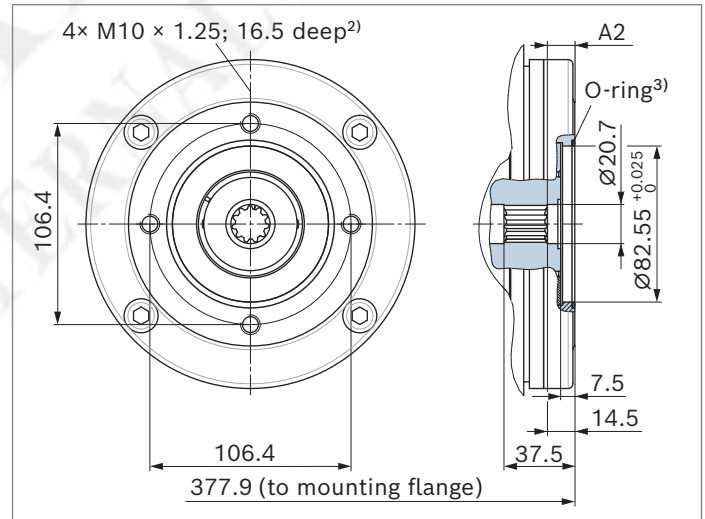

NG	A1	A2	A3	A4	A5
40	239.7	9	10	17	38
56	261.4	10	11	18	39
71	297.6	9	10	17	50

1) Involute spline according to ANSI B92.1a, 30° pressure angle, flat root, side fit, tolerance class 5

2) Thread according to DIN 13

3) O-ring included in the scope of delivery

4) Please state in plain text whether the 2-hole horizontal or the 2-hole vertical version is used.

Flange SAE J744	Hub for splined shaft ¹⁾	28	40	56	71	90	125	180	Code
101-2 (B)	7/8 in 13T 16/32DP	●	●	●	●	●	●	●	02

▼ **F02, sizes 28 to 56 (with boost pump)**

Flange SAE J744: 101-2 (B)

Hub for splined shaft: 7/8 in 13T 16/32DP¹⁾

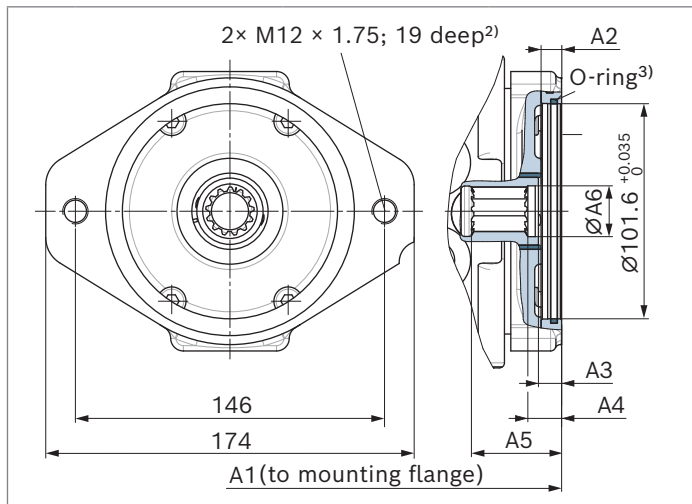

NG	A1	A2	A3	A4	A5
28	230.4	9.7	10.7	16.2	42.3
40	240.7	9.7	11	16	42.6
56	262.4	11	12	18.5	48.4

▼ **K02, sizes 28 to 56 (without boost pump)**

Flange SAE J744: 101-2 (B)

Hub for splined shaft: 7/8 in 13T 16/32DP¹⁾

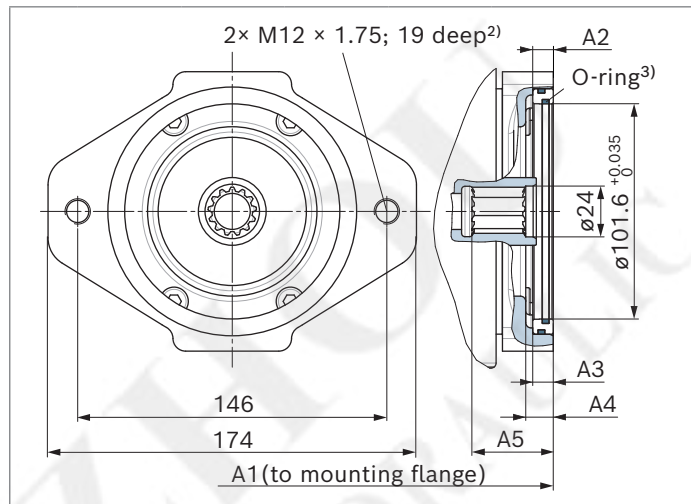

NG	A1	A2	A3	A4	A5
28	230.4	8	9.7	13.5	38.4
40	240.7	8	9.7	13	38.4
56	262.4	11	12	20.5	43.4

▼ **F02⁴⁾, size 71 (with boost pump)**

Flange SAE J744: 101-2 (B)

Hub for splined shaft: 7/8 in 13T 16/32DP¹⁾

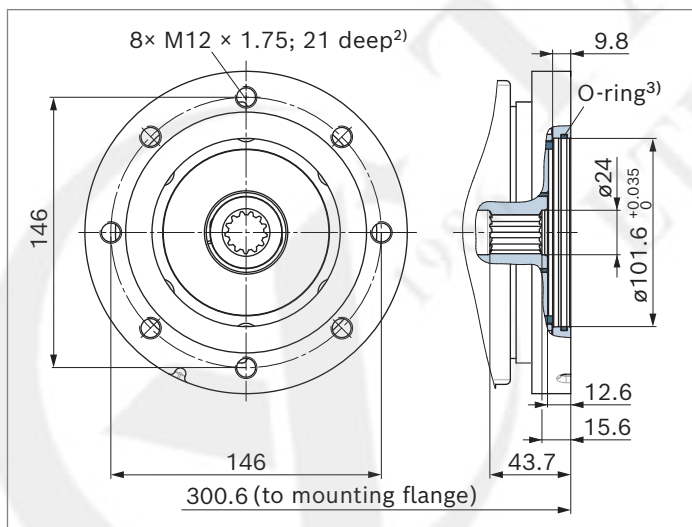

▼ **K02⁴⁾, size 71 (without boost pump)**

Flange SAE J744: 101-2 (B)

Hub for splined shaft: 7/8 in 13T 16/32DP¹⁾

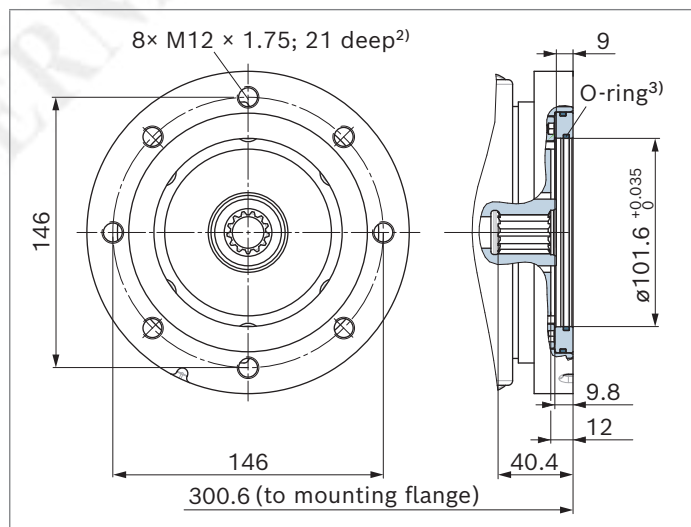

1) Involute spline according to ANSI B92.1a, 30° pressure angle, flat root, side fit, tolerance class 5

2) Thread according to DIN 13

3) O-ring included in the scope of delivery

4) Please state in plain text whether the 2-hole horizontal or the 2-hole vertical version is used.

Flange SAE J744	Hub for splined shaft ¹⁾	28	40	56	71	90	125	180	Code
101-2 (B)	7/8 in 13T 16/32DP	•	•	•	•	•	•	•	02

▼ **F02⁴⁾, size 90 (with boost pump)**

Flange SAE J744: 101-2 (B)

Hub for splined shaft: 7/8 in 13T 16/32DP¹⁾

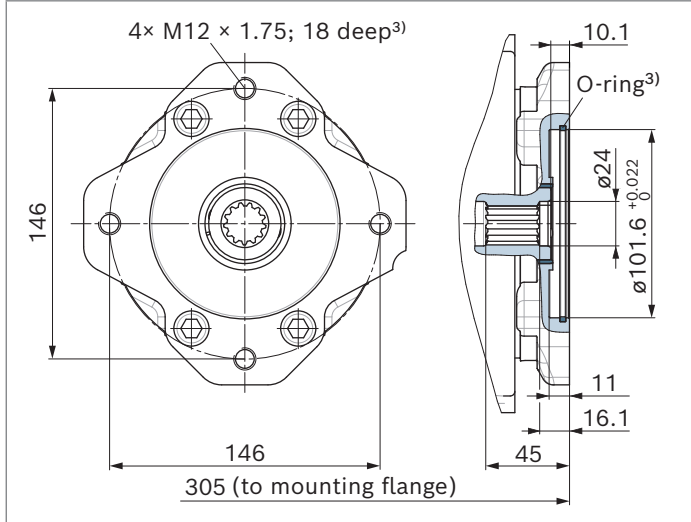

▼ **K02⁴⁾, size 90 (without boost pump)**

Flange SAE J744: 101-2 (B)

Hub for splined shaft: 7/8 in 13T 16/32DP¹⁾

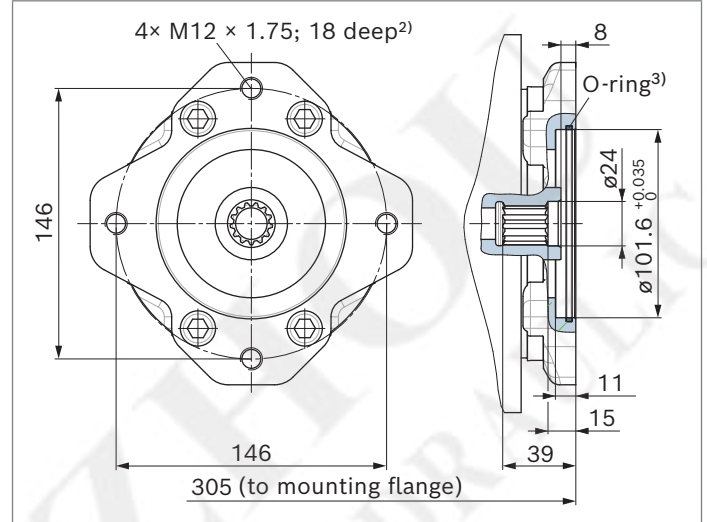

▼ **F02⁴⁾, size 125 (with boost pump)**

Flange SAE J744: 101-2 (B)

Hub for splined shaft: 7/8 in 13T 16/32DP¹⁾

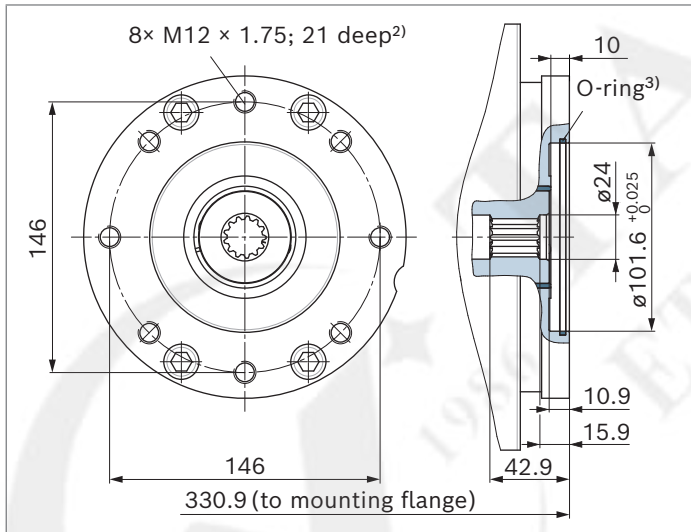

▼ **K02⁴⁾, size 125 (without boost pump)**

Flange SAE J744: 101-2 (B)

Hub for splined shaft: 7/8 in 13T 16/32DP¹⁾

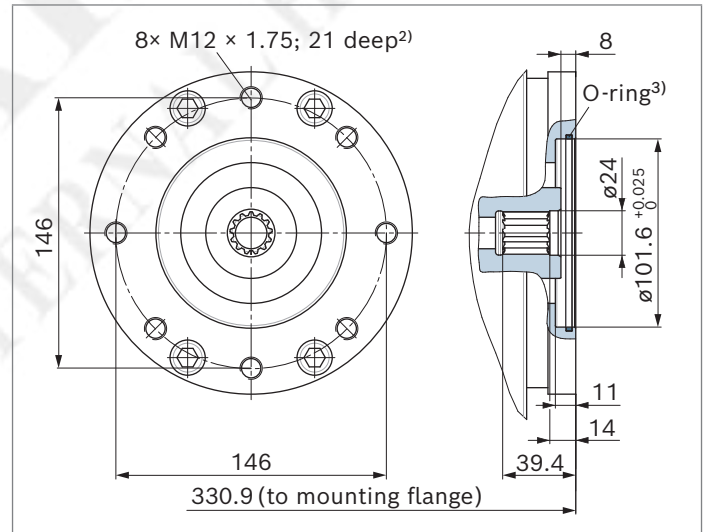

1) Involute spline according to ANSI B92.1a, 30° pressure angle, flat root, side fit, tolerance class 5

2) Thread according to DIN 13

3) O-ring included in the scope of delivery

4) Please state in plain text whether the 2-hole horizontal or the 2-hole vertical version is used.

Flange SAE J744	Hub for splined shaft ¹⁾	28	40	56	71	90	125	180	Code
101-2 (B)	7/8 in 13T 16/32DP	•	•	•	•	•	•	•	02
	1 in 15T 16/32DP	•	•	•	•	•	•	•	04

▼ **F02⁴⁾, size 180 (with boost pump)**

Flange SAE J744: 101-2 (B)
Hub for splined shaft: 7/8 in 13T 16/32DP¹⁾

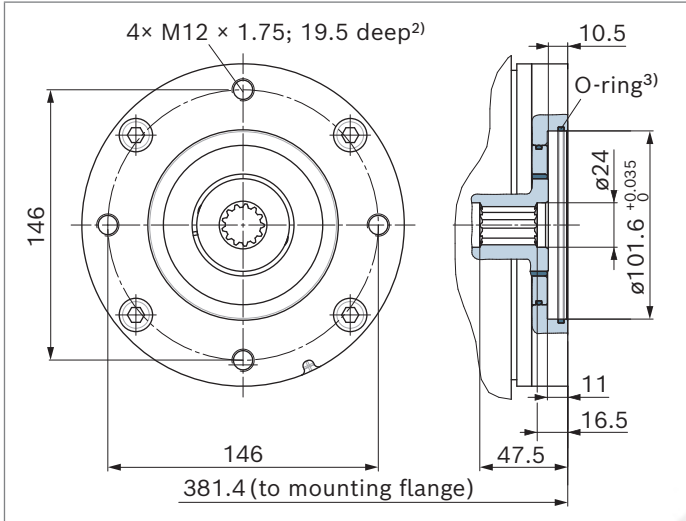

▼ **K02⁴⁾, size 180 (without boost pump)**

Flange SAE J744: 101-2 (B)
Hub for splined shaft: 7/8 in 13T 16/32DP¹⁾

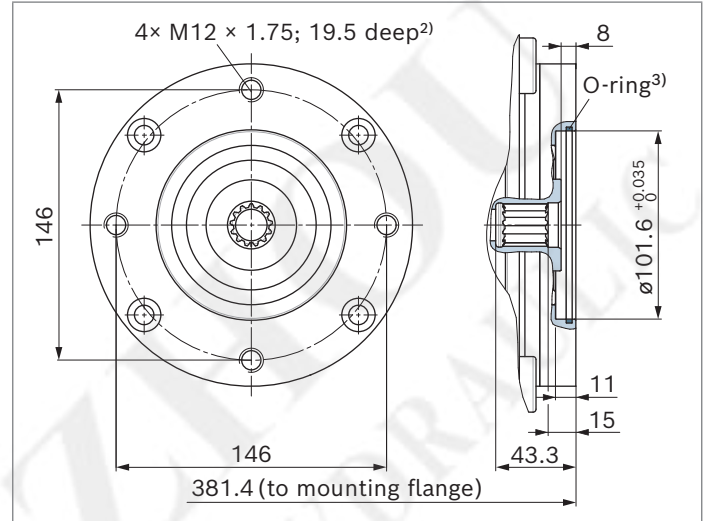

▼ **F04, sizes 28 to 56 (with boost pump)**

Flange SAE J744: 101-2 (B)
Hub for splined shaft: 1 in 15T 16/32DP¹⁾

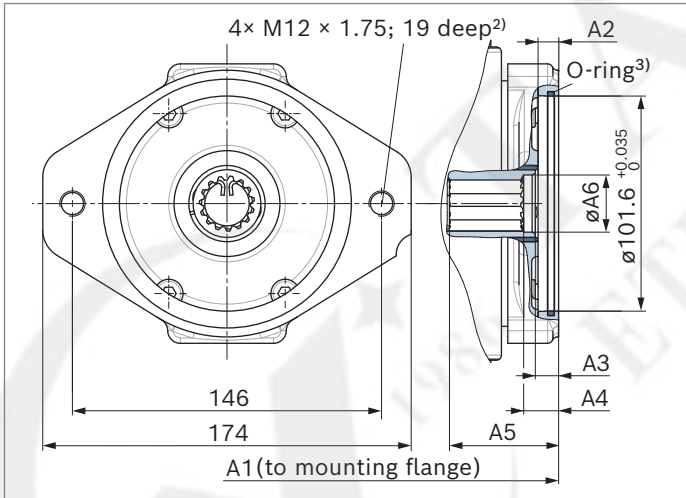

▼ **K04, sizes 28 to 56 (without boost pump)**

Flange SAE J744: 101-2 (B)
Hub for splined shaft: 1 in 15T 16/32DP¹⁾

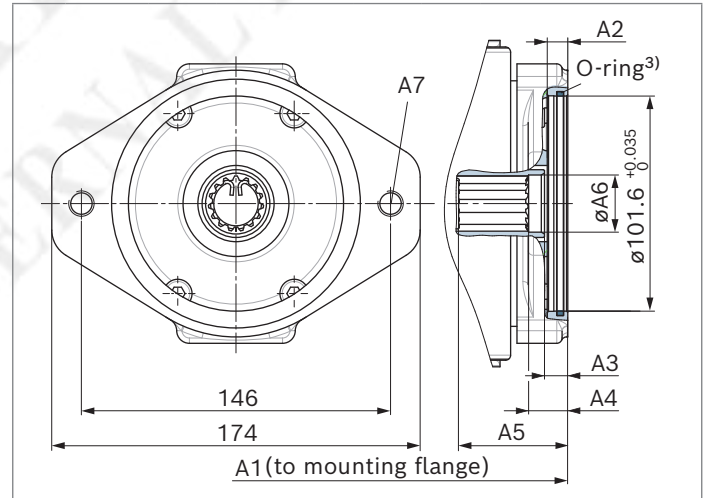

NG	A1	A2	A3	A4	A5	∅A6
28	230.4	9.7	10.7	14.7	42.4	27
40	240.7	9.7	11	16.5	51.6	27
56	262.4	11	12	18	49.1	27

NG	A1	A2	A3	A4	A5	∅A6	A7 ²⁾
28	230.4	-	10.7	16.2	42.4	-	M12 x 1.75; 19 deep
40	240.7	9.7	11	18.5	51.6	27	M12 x 1.75; 18.7 deep
56	262.4	-	9	17.5	61.7	27	M12 x 1.75; 19 deep

1) Involute spline according to ANSI B92.1a, 30° pressure angle, flat root, side fit, tolerance class 5

2) Thread according to DIN 13

3) O-ring included in the scope of delivery

4) Please state in plain text whether the 2-hole horizontal or the 2-hole vertical version is used.

Flange SAE J744	Hub for splined shaft ¹⁾	28	40	56	71	90	125	180	Code
101-2 (B)	1 in 15T 16/32DP ¹⁾	•	•	•	•	•	•	•	04

▼ F04⁴⁾, size 71 (with boost pump)

Flange SAE J744: 101-2 (B)

Hub for splined shaft: 1 in 15T 16/32DP¹⁾

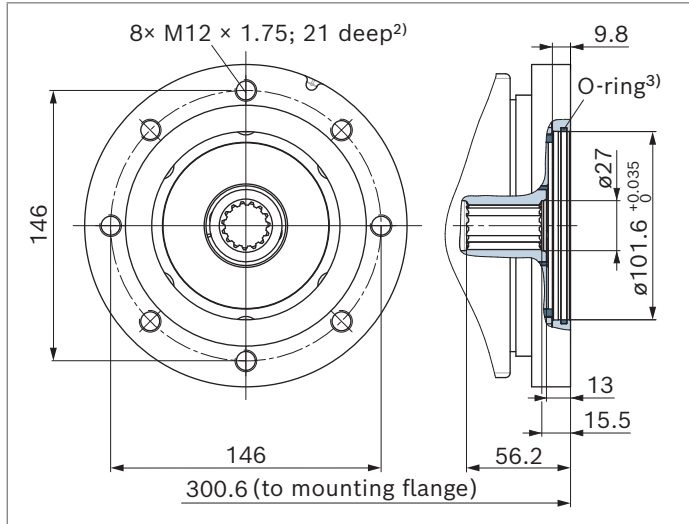

▼ K04⁴⁾, size 71 (without boost pump)

Flange SAE J744: 101-2 (B)

Hub for splined shaft: 1 in 15T 16/32DP¹⁾

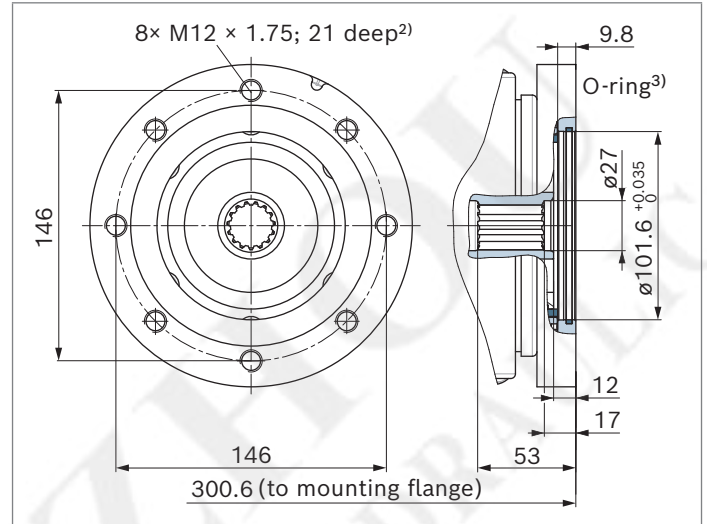

▼ F04⁴⁾, size 90 (with boost pump)

Flange SAE J744: 101-2 (B)

Hub for splined shaft: 1 in 15T 16/32DP¹⁾

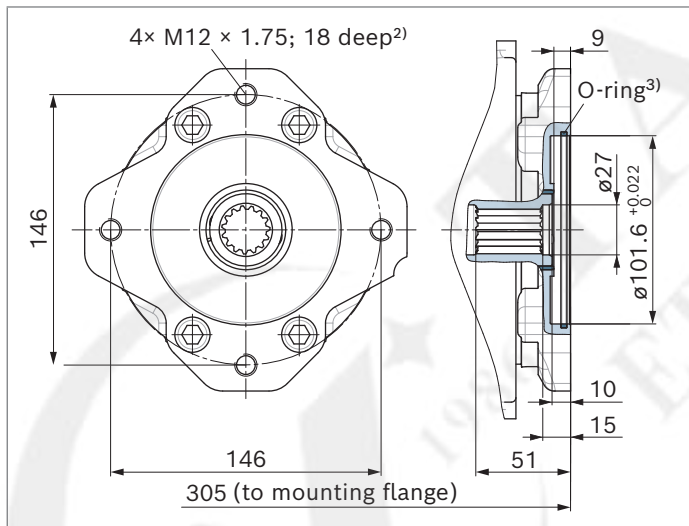

▼ K04⁴⁾, size 71 (without boost pump)

Flange SAE J744: 101-2 (B)

Hub for splined shaft: 1 in 15T 16/32DP¹⁾

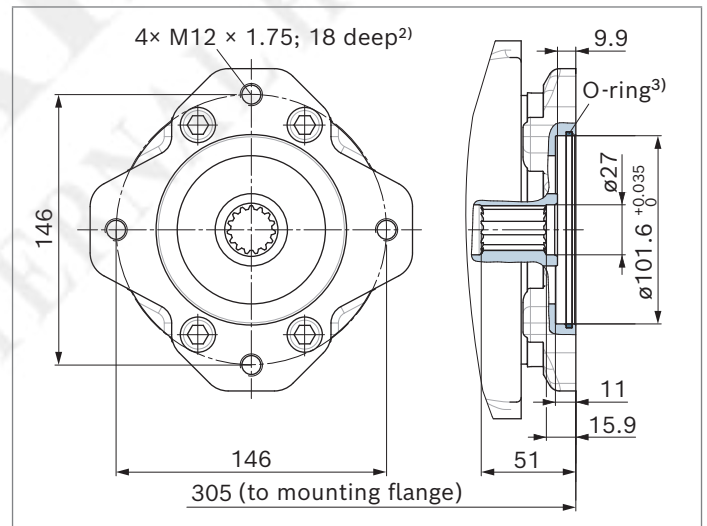

1) Involute spline according to ANSI B92.1a, 30° pressure angle, flat root, side fit, tolerance class 5

2) Thread according to DIN 13

3) O-ring included in the scope of delivery

4) Please state in plain text whether the 2-hole horizontal or the 2-hole vertical version is used.

Flange SAE J744	Hub for splined shaft ¹⁾	28	40	56	71	90	125	180	Code
101-2 (B)	1 in 15T 16/32DP	●	●	●	●	●	●	●	04

▼ **F04⁴⁾, size 125 (with boost pump)**

Flange SAE J744: 101-2 (B)

Hub for splined shaft: 1 in 15T 16/32DP¹⁾

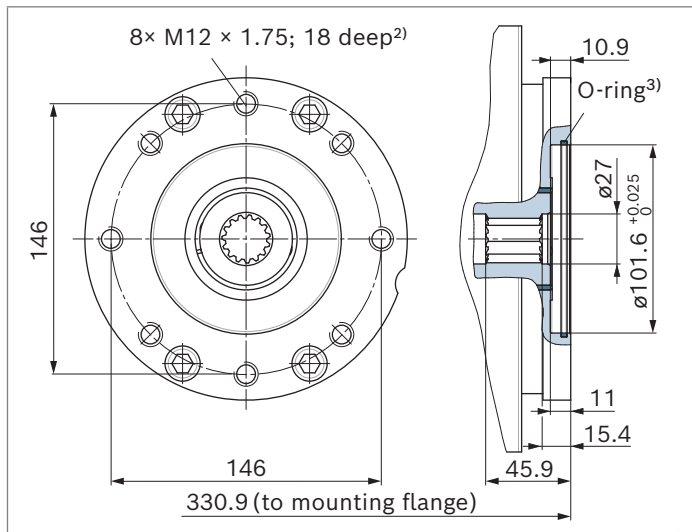

▼ **K04⁴⁾, size 125 (without boost pump)**

Flange SAE J744: 101-2 (B)

Hub for splined shaft: 1 in 15T 16/32DP¹⁾

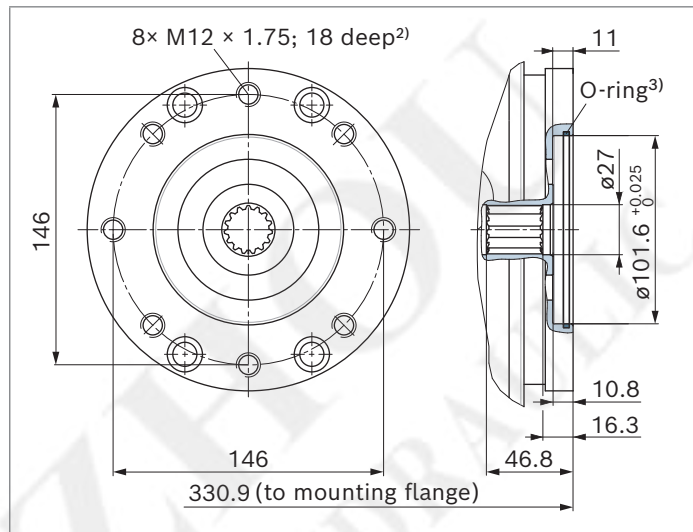

▼ **F04⁴⁾, size 180 (with boost pump)**

Flange SAE J744: 101-2 (B)

Hub for splined shaft: 1 in 15T 16/32DP¹⁾

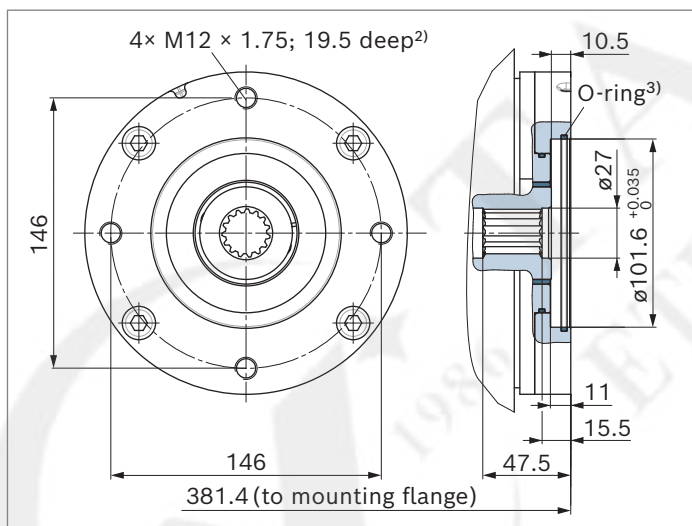

▼ **K04⁴⁾, size 180 (without boost pump)**

Flange SAE J744: 101-2 (B)

Hub for splined shaft: 1 in 15T 16/32DP¹⁾

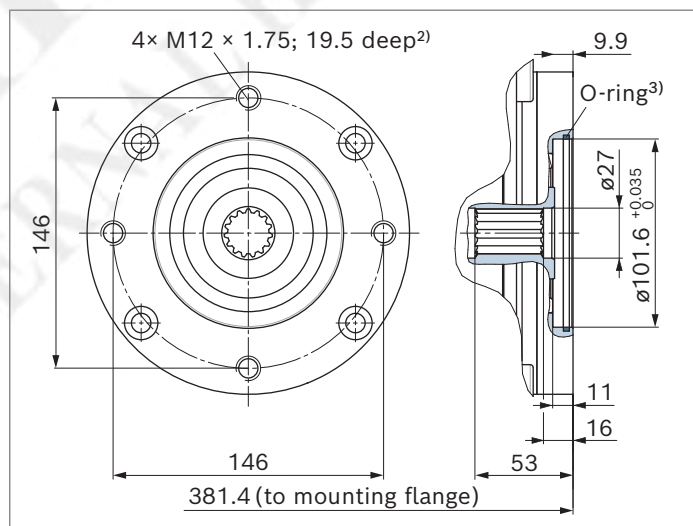

1) Involute spline according to ANSI B92.1a, 30° pressure angle, flat root, side fit, tolerance class 5

2) Thread according to DIN 13

3) O-ring included in the scope of delivery

4) Please state in plain text whether the 2-hole horizontal or the 2-hole vertical version is used.

Flange SAE J744	Hub for splined shaft ¹⁾	28	40	56	71	90	125	180	Code
127-2 (C)	1 in 15T 16/32DP ⁷⁾	-	●	-	-	-	-	-	09
127-2 (C)	1 1/4 in 14T 12/24DP ⁷⁾	-	-	●	●	-	-	●	07
127-2/4 (C)		-	-	-	-	●	●	-	

▼ **F09, size 40 (with boost pump)**

Flange SAE J744: 127-2 (C)

Hub for splined shaft: 1 in 15T 16/32DP¹⁾

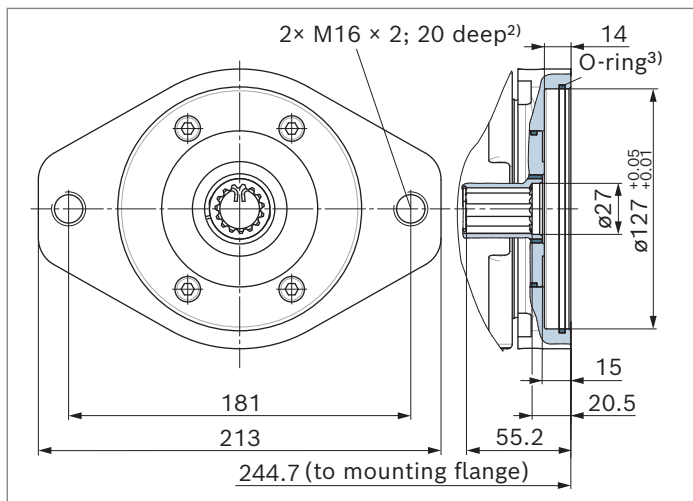

▼ **K09, size 40 (without boost pump)**

Flange SAE J744: 127-2 (C)

Hub for splined shaft: 1 in 15T 16/32DP¹⁾

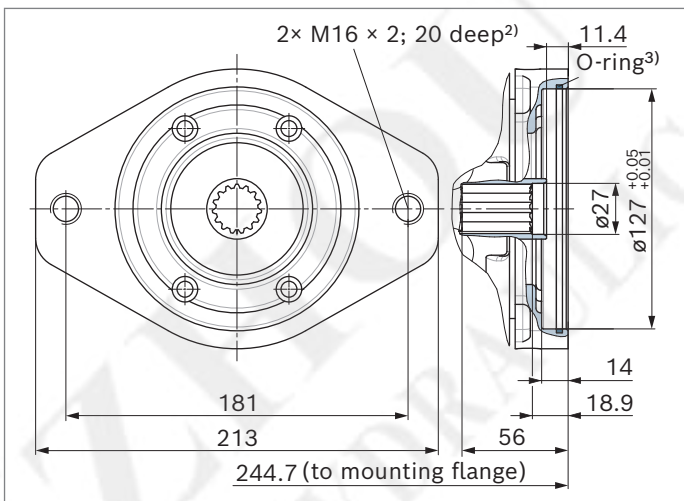

▼ **F07⁴⁾, size 56 (with boost pump)**

Flange SAE J744: 127-2 (C)

Hub for splined shaft: 1 1/4 in 14T 12/24DP¹⁾

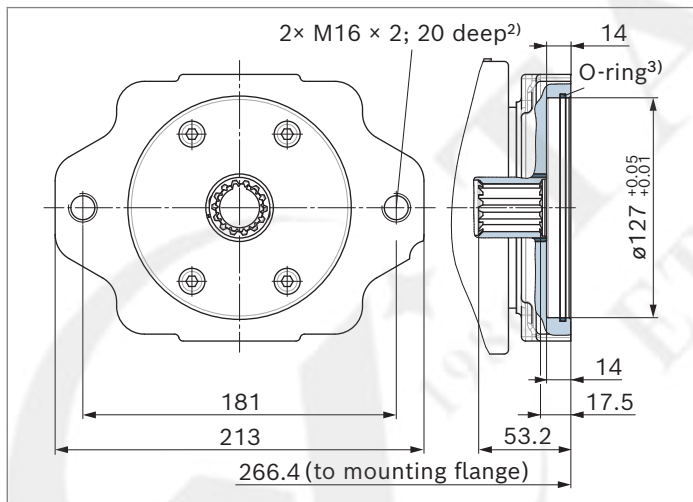

▼ **K07⁴⁾, size 56 (without boost pump)**

Flange SAE J744: 127-2 (C)

Hub for splined shaft: 1 1/4 in 14T 12/24DP¹⁾

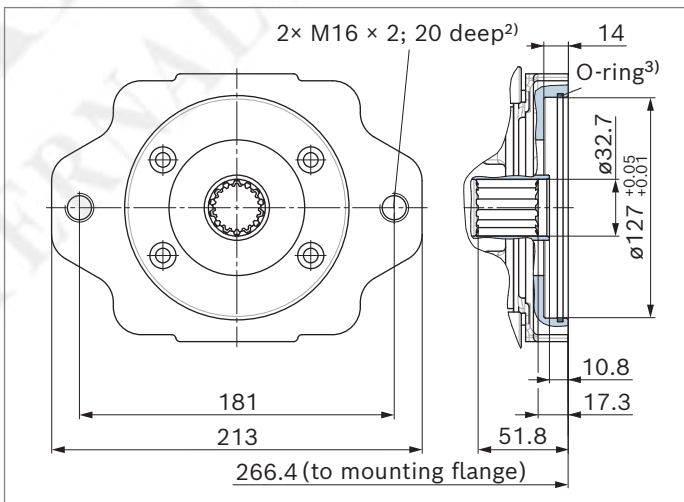

1) Involute spline according to ANSI B92.1a, 30° pressure angle, flat root, side fit, tolerance class 5

2) Thread according to DIN 13

3) O-ring included in the scope of delivery

4) Please state in plain text whether the 2-hole horizontal or the 2-hole vertical version is used.

Flange SAE J744	Hub for splined shaft ¹⁾	28	40	56	71	90	125	180	Code
127-2 (C)	1 1/4 in 14T 12/24DP	-	-	●	●	-	-	●	07
127-2/4 (C)		-	-	-	-	●	●	-	

▼ **F07, size 71 (with boost pump)**

Flange SAE J744: 127-2 (C)

Hub for splined shaft: 1 1/4 in 14T 12/24DP¹⁾

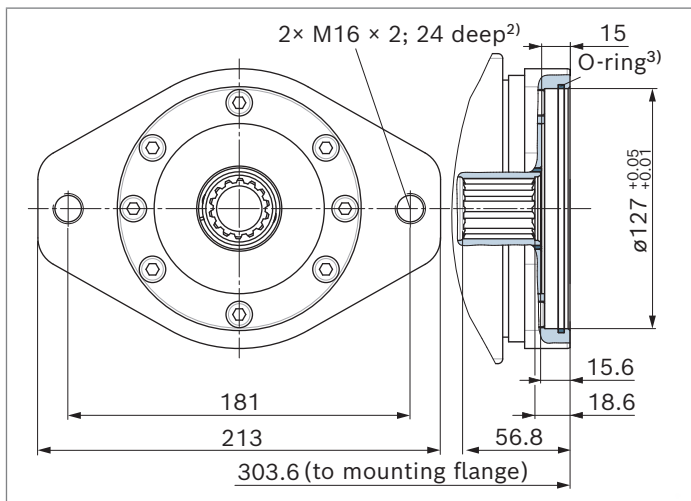

▼ **K07, size 71 (without boost pump)**

Flange SAE J744: 127-2 (C)

Hub for splined shaft: 1 1/4 in 14T 12/24DP¹⁾

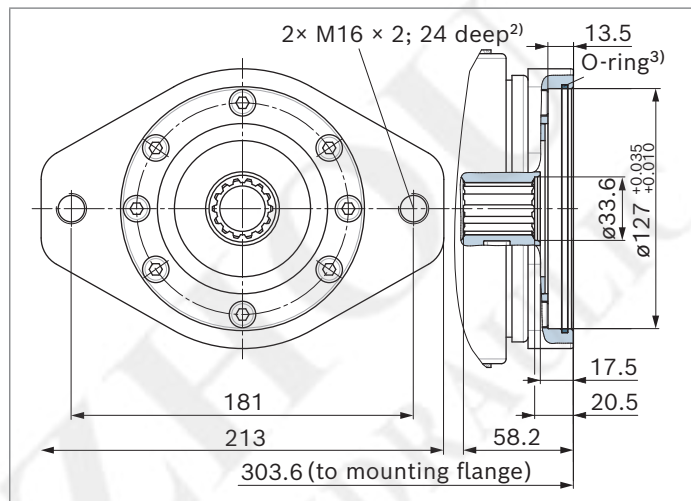

▼ **F07⁴⁾, size 90 (with boost pump)**

Flange SAE J744: 127-2/4 (C)

Hub for splined shaft: 1 1/4 in 14T 12/24DP¹⁾

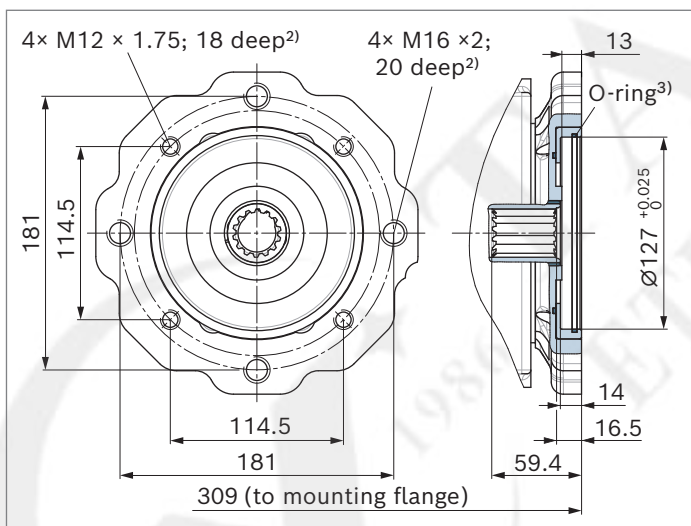

▼ **K07⁴⁾, size 90 (without boost pump)**

Flange SAE J744: 127-2/4 (C)

Hub for splined shaft: 1 1/4 in 14T 12/24DP¹⁾

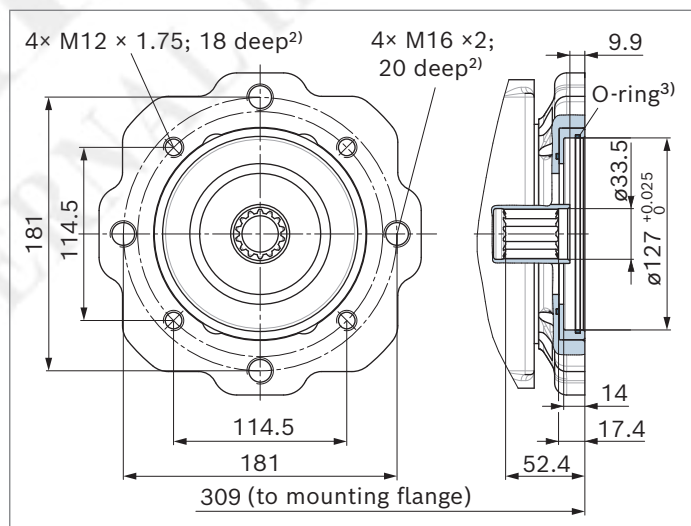

1) Involute spline according to ANSI B92.1a, 30° pressure angle, flat root, side fit, tolerance class 5

2) Thread according to DIN 13

3) O-ring included in the scope of delivery

4) Please state in plain text whether the 4-hole, the 2-hole horizontal or the 2-hole vertical version is used.

Flange SAE J744	Hub for splined shaft ¹⁾	28	40	56	71	90	125	180	Code
127-2 (C)	1 1/4 in 14T 12/24DP ⁷⁾	-	-	●	●	-	-	●	07
127-2/4 (C)		-	-	-	-	●	●	-	

▼ **F07⁴⁾, size 125 (with boost pump)**

Flange SAE J744: 127-2/4 (C)

Hub for splined shaft: 1 1/4 in 14T 12/24DP¹⁾

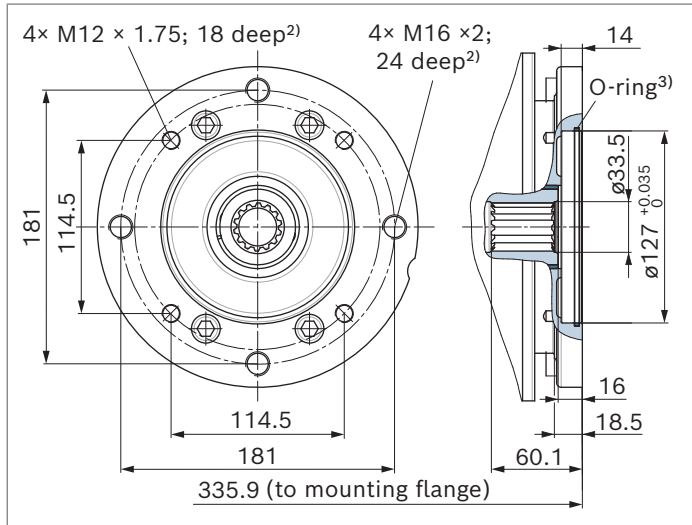

▼ **K07⁴⁾, size 125 (without boost pump)**

Flange SAE J744: 127-2/4 (C)

Hub for splined shaft: 1 1/4 in 14T 12/24DP¹⁾

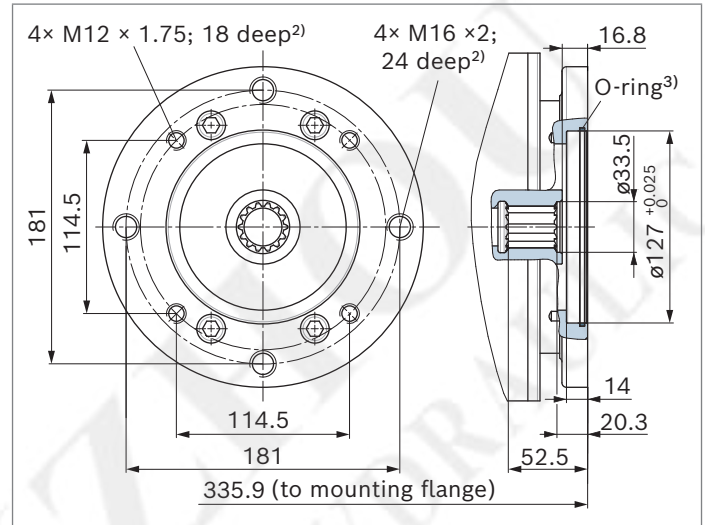

▼ **F07⁵⁾, size 180 (with boost pump)**

Flange SAE J744: 127-2 (C)

Hub for splined shaft: 1 1/4 in 14T 12/24DP¹⁾

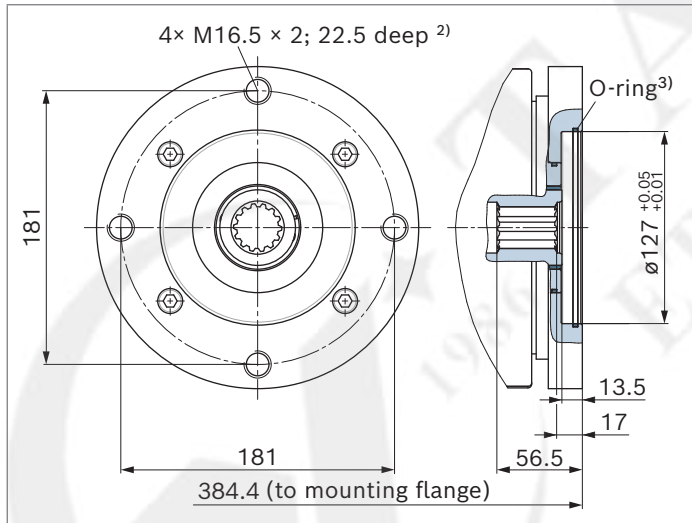

- 1) Involute spline according to ANSI B92.1a, 30° pressure angle, flat root, side fit, tolerance class 5
- 2) Thread according to DIN 13
- 3) O-ring included in the scope of delivery
- 4) Please state in plain text whether the 4-hole, the 2-hole horizontal or the 2-hole vertical version is used.
- 5) Please state in plain text whether the 2-hole horizontal or the 2-hole vertical version is used.

Flange SAE J744	Hub for splined shaft	28	40	56	71	90	125	180	Code
152-2/4 (D)	W35 2×16×9g (according to DIN 5480)	-	-	-	-	●	-	-	73
	1 3/4 in 13T 8/16DP ¹⁾	-	-	-	-	-	●	●	69

▼ **F73⁴⁾, size 90 (with boost pump)**

Flange SAE J744: 152-2/4 (D)

Hub for splined shaft: W35 2×16×9g according to DIN 5480

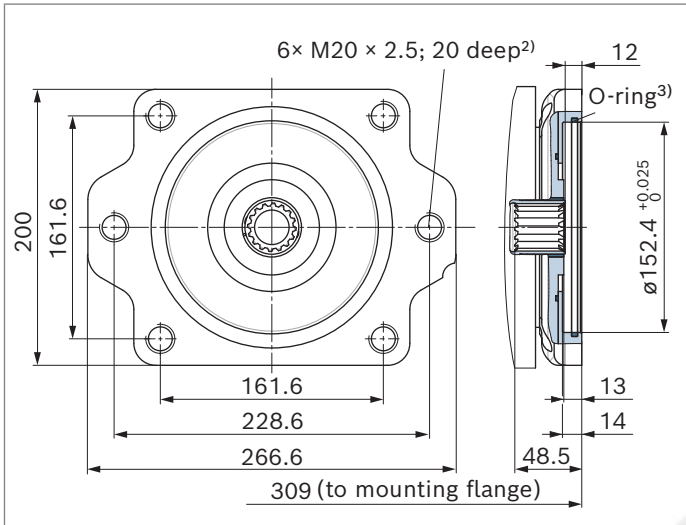

▼ **K73⁴⁾, size 90 (without boost pump)**

Flange SAE J744: 152-2/4 (D)

Hub for splined shaft: W35 2×16×9g according to DIN 5480

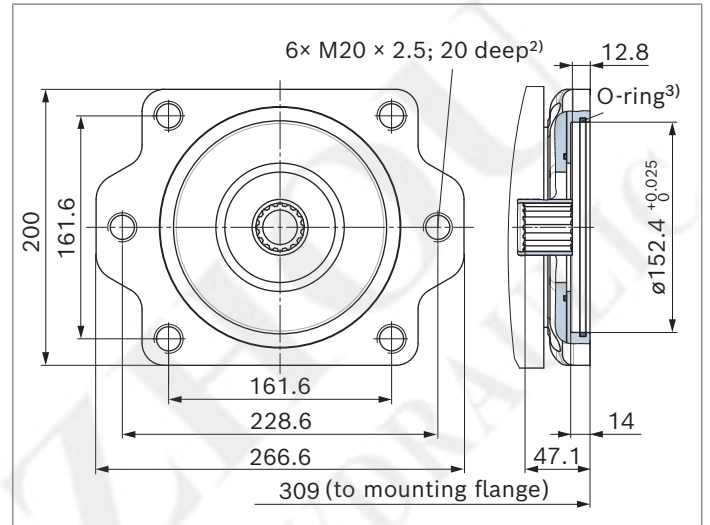

▼ **F69⁴⁾, size 125 (with boost pump)**

Flange SAE J744: 152-2/4 (D)

Hub for splined shaft: 1 3/4 in 13T 8/16DP¹⁾

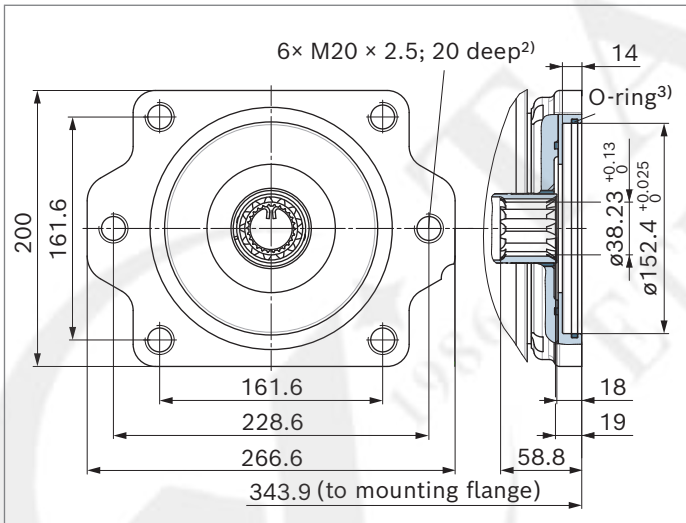

▼ **K69⁴⁾, size 125 (without boost pump)**

Flange SAE J744: 152-2/4 (D)

Hub for splined shaft: 1 3/4 in 13T 8/16DP¹⁾

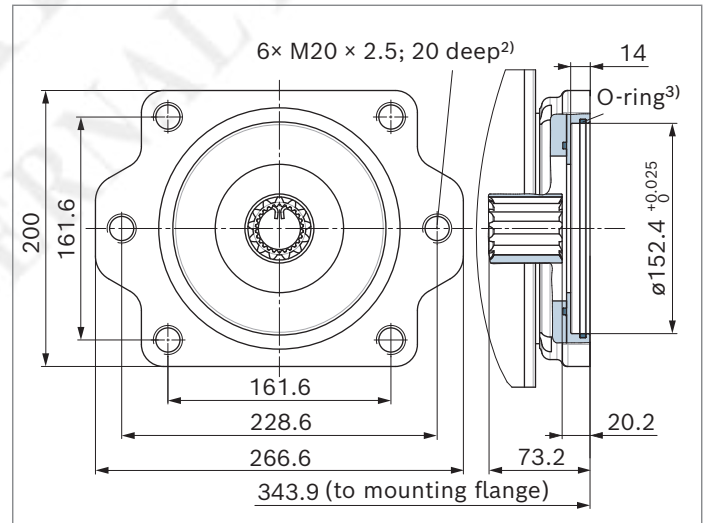

1) Involute spline according to ANSI B92.1a, 30° pressure angle, flat root, side fit, tolerance class 5

2) Thread according to DIN 13

3) O-ring included in the scope of delivery

4) Please state in plain text whether the 2-hole, the 4-hole or the 4+2-hole vertical version is used.

Flange SAE J744	Hub for splined shaft	28	40	56	71	90	125	180	Code
152-2/4 (D)	1 3/4 in 13T 8/16DP ¹⁾	-	-	-	-	-	●	●	69
164-4 (E)	1 3/4 in 13T 8/16DP ¹⁾	-	-	-	-	-	-	●	72

▼ **F69⁴⁾, size 180 (with boost pump)**

Flange SAE J744: 152-2/4 (D)

Hub for splined shaft: 1 3/4 in 13T 8/16DP¹⁾

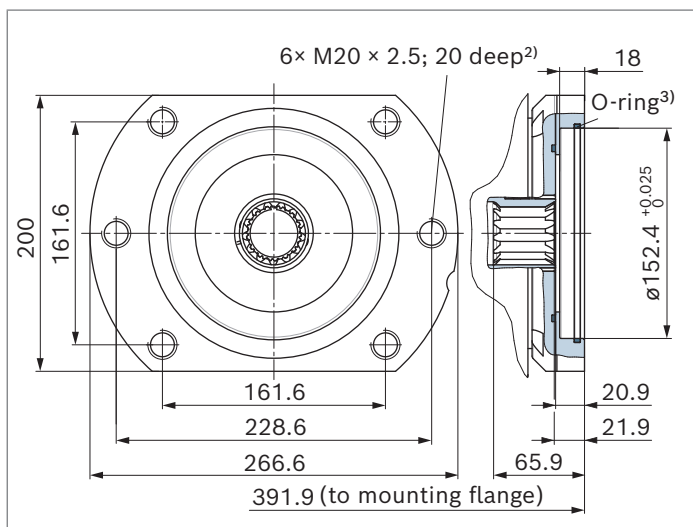

▼ **K69⁴⁾, size 180 (without boost pump)**

Flange SAE J744: 152-2/4 (D)

Hub for splined shaft: 1 3/4 in 13T 8/16DP¹⁾

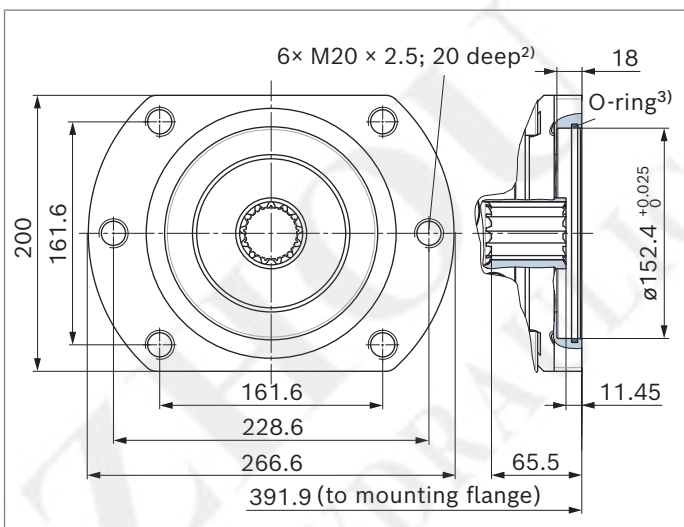

▼ **F72, size 180 (with boost pump)**

Flange SAE J744: 164-4 (E)

Hub for splined shaft: 1 3/4 in 13T 8/16DP¹⁾

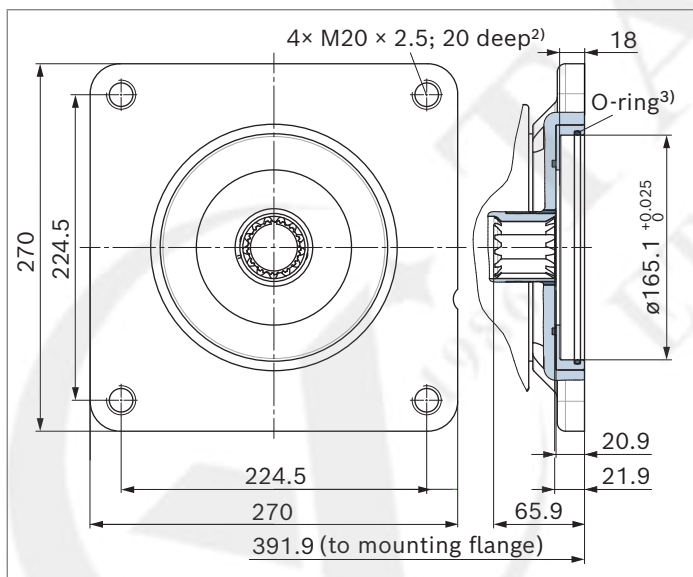

▼ **K72, size 180 (without boost pump)**

Flange SAE J744: 164-4 (E)

Hub for splined shaft: 1 3/4 in 13T 8/16DP¹⁾

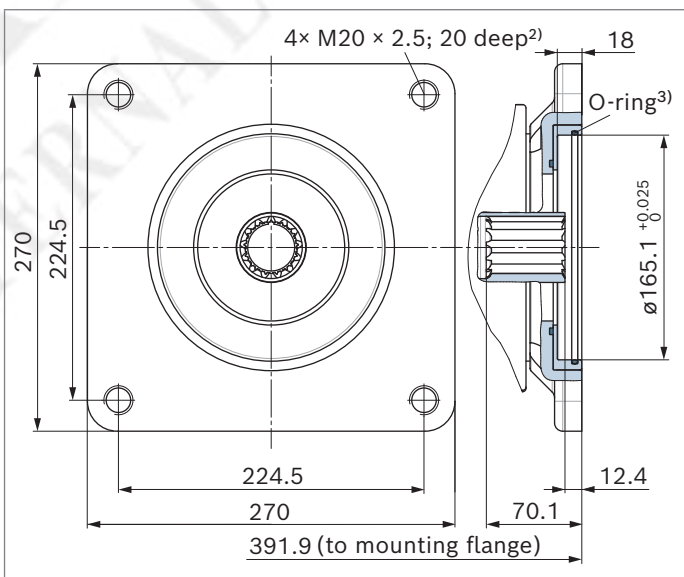

- 1) Involute spline according to ANSI B92.1a, 30° pressure angle, flat root, side fit, tolerance class 5
- 2) Thread according to DIN 13
- 3) O-ring included in the scope of delivery
- 4) Please state in plain text whether the 2-hole, the 4-hole or the 4+2-hole vertical version is used.

Overview of mounting options

Through drive ¹⁾			Mounting options – 2nd pump			
Flange	Hub for splined shaft	Code	A4VG/32 NG (shaft)	A4VG/35 NG (shaft)	A10VG/10 NG (shaft)	External gear pump ²⁾
82-2 (A)	5/8 in	F/K01	–	–	–	AZPF, AZPS NG4 ... 28, AZPW NG5 ... 22
	3/4 in	F52	–	–	–	AZPF NG4 ... 28
101-2 (B)	7/8 in	F/K02	–	–	18 (S)	AZPN-11 NG20 ... 25, AZPG-22 NG28 ... 100
	1 in	F/K04	28 (S)	–	28 (S) 45 (S)	–
127-2 (C) ³⁾	1 in	F/K09	40 (U)	–	–	–
	1 1/4 in	F/K07	40, 56, 71 (S)	56, 71, 90 (S7)	63 (S)	–
127-4 (C) ³⁾	1 in	F/K09	–	–	–	–
	1 1/4 in	F/K07	71 (S)	71, 90 (S7)	–	–
152-2 (D)	W35	F/K73	90 (Z)	–	–	–
	1 3/4 in	F/K69	90, 125 (S)	–	–	–
152-4 (D)	W35	F/K73	90 (Z)	–	–	–
	1 3/4 in	F/K69	90, 125 (S)	–	–	–
165-4 (E)	1 3/4 in	F/K72	180 (S)	–	–	–

Through drive ¹⁾			Mounting options – 2nd pump				
Flange	Hub for splined shaft	Code	A10V(S)O/31 NG (shaft)	A10VO/32 NG (shaft)	A10V(S)O/5x NG (shaft)	A11VO/1x NG (shaft)	A1VO/10
82-2 (A)	5/8 in	F/K01	18 (U)	–	10, 18 (U)	–	–
	3/4 in	F52	18 (S)	–	10, 18 (S)	–	18, 28 (S3)
101-2 (B)	7/8 in	F/K02	28 (S) 45 (U)	45 (U)	28 (S) 45 (U)	–	18, 28, 35 (S4)
	1 in	F/K04	45 (S)	45 (S)	45 (S) 60, 63, 72 (U)	40 (S)	35 (S5)
127-2 (C)	1 in	F/K09	71, 88 (U)	71 (U)	–	–	–
	1 1/4 in	F/K07	71, 88 (S) 100 (U)	71 (S) 100 (U)	85, 100 (U)	–	–
127-4 (C) ³⁾	1 in	F/K09	–	45 (S) 71 (U)	60, 63, 72 (U)	–	–
	1 1/4 in	F/K07	–	71 (S)	60, 63, 72 (S) 85, 100 (U)	60 (S)	–
152-2 (D)	W35	F/K73	–	–	–	–	–
	1 3/4 in	F/K69	–	–	–	–	–
152-4 (D)	W35	F/K73	–	–	–	–	–
	1 3/4 in	F/K69	140 (S)	140, 180 (S)	–	95, 130, 145 (S)	–
165-4 (E)	1 3/4 in	F/K72	–	–	–	190 (S)	–

Notice

The mounting options listed only apply for drive shaft versions with undercut. Please contact us for drive shafts without undercut.

- 1) Availability of the individual sizes, see type code on page 2.
- 2) We recommend special versions of the gear pumps. Please contact us.
- 3) A10VO/5X with 4-hole flange attachable only to A4VG NG90 to 180

Combination pumps A4VG + A4VG

Total length A

A4VG 1st pump	A4VG 2nd pump ¹⁾						
	NG28	NG40	NG56	NG71	NG90	NG125	NG180
NG28	453.8	–	–	–	–	–	–
NG40	464.1	480.4	–	–	–	–	–
NG56	485.8	502.1	522.8	–	–	–	–
NG71	524.0	539.3	560.0	597.2	–	–	–
NG90	528.4	544.7	565.4	602.6	610.0	–	–
NG125	554.3	571.6	592.3	629.5	644.9	670.3	–
NG180	604.8	620.1	640.8	678.0	692.9	718.3	762.8

By using combination pumps, it is possible to have independent circuits without the need for splitter gearboxes. When ordering combination pumps the type designations for the 1st and the 2nd pump must be linked by a "+".

Order example:

A4VG56EP3D1/32R-NAC02F073SP + A4VG56EP3D1/32R-NSC02F003SP

A tandem pump, with two pumps of equal size, is permissible without additional supports, assuming that the dynamic mass acceleration does not exceed maximum 10 g (= 98.1 m/s²).

From size 71 upward, we recommend using the 4-hole mounting flange.

For combination pumps consisting of more than two pumps, the mounting flange must be rated for the permissible moment of inertia, please contact us.

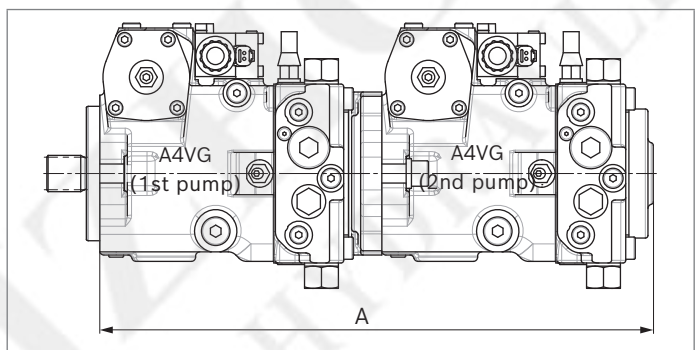

Notice

- ▶ The combination pump type code is shown in shortened form in the order confirmation.
- ▶ The permissible through-drive torques are to be observed (see page 12).

1) 2nd pump without through drive and with boost pump, F00

High-pressure relief valves

The two high-pressure relief valves protect the hydrostatic gear (pump and motor) from overloading. They limit the maximum pressure in the respective high-pressure line and serve simultaneously as boost valves.

High-pressure relief valves are not working valves and are only suitable for pressure peaks or high rates of pressure change.

Setting ranges

High-pressure relief valve, direct operated (NG28 to 56)	Differential pressure setting Δp_{HD}
Setting range valve 3, 5	420 bar
Δp_{HD} 250 to 420 bar (see type code)	400 bar
	360 bar
	340 bar
	320 bar
	300 bar
	270 bar
	250 bar
Setting range valve 4, 6	250 bar
Δp_{HD} 100 to 250 bar (see type code)	230 bar
	200 bar
	150 bar
	100 bar

High-pressure relief valve, pilot operated (NG71 to 180)	Differential pressure setting Δp_{HD}
Setting range valve 1	420 bar
Δp_{HD} 100 to 420 bar (see type code)	400 bar
	360 bar
	340 bar
	320 bar
	300 bar
	270 bar
	250 bar
	230 bar
	200 bar
	150 bar
	100 bar

1) Size 28 without port F_{a1} and F_s

2) Only sizes 28 to 71 are designed with inlet filtration in X_1/X_2

Settings on high-pressure relief valve A and B

Differential pressure setting $\Delta p_{HD} = \dots$ bar

Cracking pressure of the HD valve (at q_{V1}) $p_{max} = \dots$ bar
($p_{max} = \Delta p_{HD} + p_{Sp}$)

- ▶ The valve settings are made at $n = 1000$ rpm and at $V_{g\ max}$ (q_{V1}). There may be deviations in the cracking pressures with other operating parameters.
- ▶ When ordering, state the differential pressure setting Δp_{HD} in the plain text.

▼ Circuit diagram¹⁾

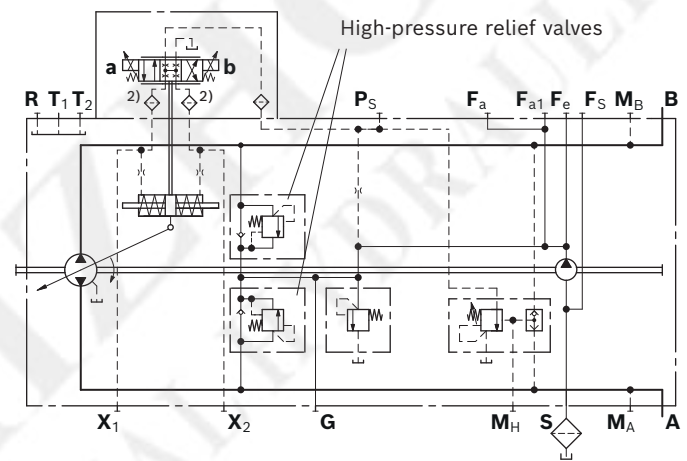

Example: Δp drive design = 370 bar ($p_{A, B} - p_{Sp}$)

Working pressure $p_{A, B}$	- Boost pressure p_{Sp}	+ Safety	= Differential pressure Δp_{HD}
390 bar	- 20 bar	+ 30 bar	= 400 bar

- ▶ Cracking pressure of the HD valve (at q_{V1}):
 $p_{max} = 420$ bar ($p_{max} = \Delta p_{HD} + p_{Sp}$)

▼ Setting diagram

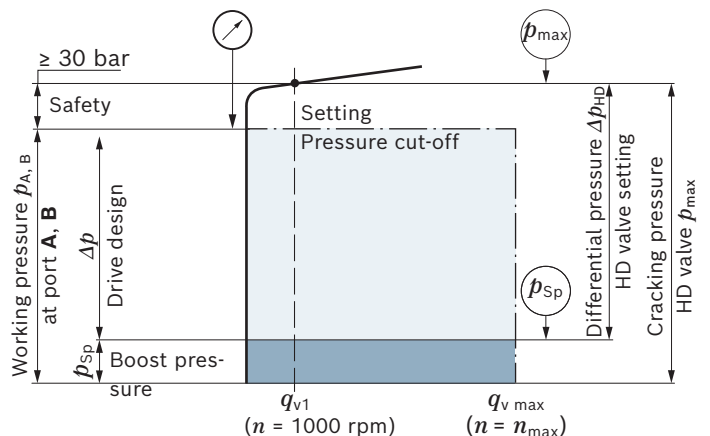

Key	
HD valve	High-pressure relief valve
Cracking pressure HD valve p_{max}	When the set pressure value is reached, the HD valve opens and thus protects the hydrostatic gear (pump and motor) from overloading
Differential pressure HD valve Δp_{HD}	Cracking pressure HD valve (abs.) minus the boost pressure setting
Working pressure $p_{A, B}$	The total design of the customer machine is based on this pressure value. It comprises the boost pressure setting and the Δp drive design.
Δp Drive design	Differential pressure value determining the available torque at the hydraulic motor ($p_{A, B} - p_{Sp}$).
Boost pressure p_{Sp}	Boost pressure setting of the low-pressure valve
Safety	Required distance between working pressure (and/or pressure cut-off) and cracking pressure of the high-pressure relief valve to ensure the intended function of the high-pressure relief valve.

Notice

Upon response of the high-pressure relief valve, the permissible temperature and viscosity must be complied with.

Bypass function

A connection between the two high-pressure passages **A** and **B** can be established using the bypass function (e.g. for machine towing).

► Towing speed

The maximum towing speed depends on the gear ratio in the vehicle and must be calculated by the vehicle manufacturer. The corresponding flow of $q_v = 30$ l/min may not be exceeded.

► Towing distance

Only tow the vehicle out of the immediate danger zone.

For further information on the bypass function, see the instruction manual.

Notice

The bypass function and the pilot operated high-pressure relief valves (size 71 to 180) are not illustrated in the circuit diagrams.

Pressure cut-off

The pressure cut-off is a pressure control which, after reaching the set pressure, adjusts the displacement of the pump back to $V_{g \min}$.

This valve prevents the operation of the high-pressure relief valves when accelerating or decelerating.

The high-pressure relief valves protect against the pressure peaks which occur during fast swiveling of the swashplate and limit the maximum pressure in the system.

The setting range of the pressure cut-off may be anywhere within the entire working pressure range. However, it must be set 30 bar lower than the setting value of the high-pressure relief valves (see setting diagram, page 85).

The function of the pressure cut-off in combination with a DG control is described on page 21.

Please state the setting value of the pressure cut-off in plain text when ordering.

▼ Circuit diagram with pressure cut-off

Example: Two-point control, electric, E21D/E22D

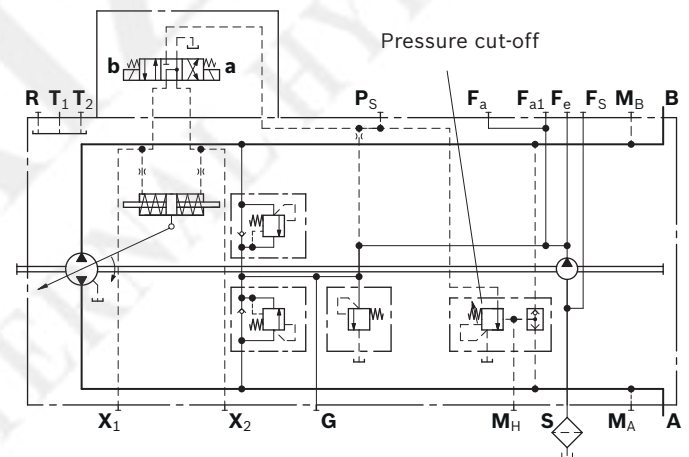

Mechanical stroke limiter

The mechanical stroke limiter is an auxiliary function allowing the maximum displacement of the pump to be steplessly reduced, regardless of the control module used. By means of two threaded pins, the stroke of the stroking piston and thus the maximum swivel angle of the pump can be limited.

Notice

Threaded pins are mounted from the inside (screw-out protection) and can no longer be removed from the outside.

Dimensions

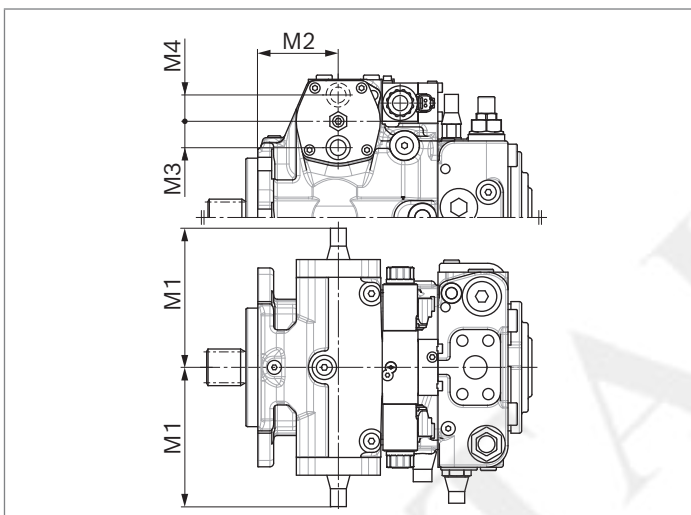

NG	M1 max.	M2	M3	M4
28	125.5	40.1	24	-
40	125.5	38.1	24	-
56	141.5	44	25.5	-
71	151	86.3	-	28.5
90	155	95.7	31.5	-
125	177.5	104.5	-	35.5
180	184.5	138.7	38	-

▼ Circuit diagram¹⁾

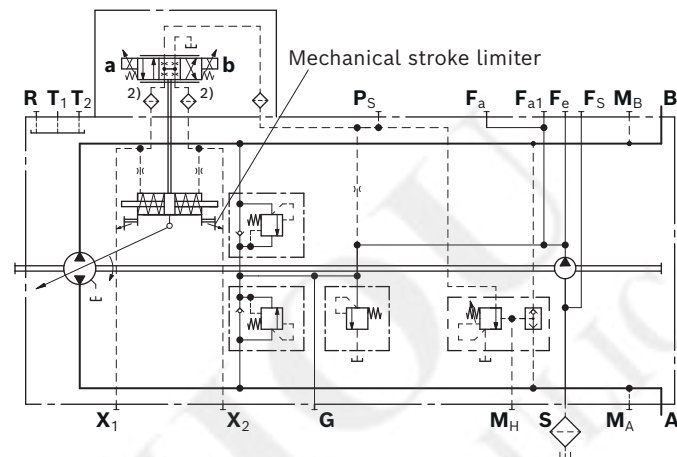

1) Size 28 without port F_{a1} and F_s

2) Only sizes 28 to 71 are designed with inlet filtration in X_1/X_2

Stroking chamber pressure port X₃ and X₄

Dimensions

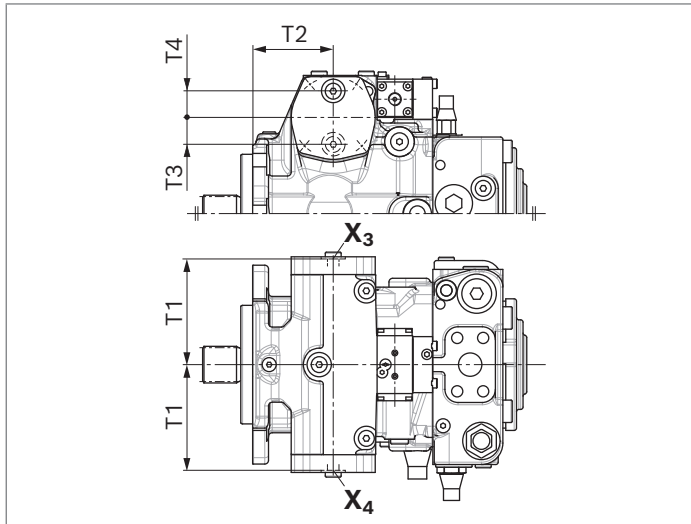

NG	T1	T2	T3	T4
28	92	40.1	-	24
40	92	38.1	-	24
56	104.5	44	-	25
71	113.5	86.3	28	-
90	111.5	95.7	-	30
125	136	104.5	34	-
180	146.5	138.7	-	35

▼ Circuit diagram¹⁾

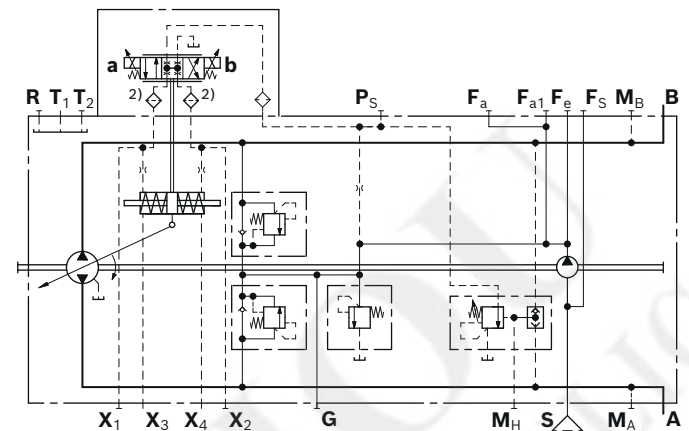

Ports	Standard ³⁾	Size	p_{max} [bar] ⁴⁾	State ⁵⁾
X ₃ , X ₄ Stroking chamber pressure port	DIN 3852	M12 × 1.5; 12 deep	40	X

1) Size 28 without port F_{a1} and F_s

2) Only sizes 28 to 71 are designed with inlet filtration in X₁/X₂

3) The countersink can be deeper than specified in the standard.
Ports designed for straight stud ends according to EN ISO 9974-2 type E.

4) Depending on the application, momentary pressure peaks can occur. Keep this in mind when selecting measuring devices and fittings.

5) X = Plugged (in normal operation)

Measuring ports M_A , M_B , M_H

Working port (port plate) based on DIN 3852

The measuring ports M_A , M_B and M_H are designed according to DIN 3852 and designed for straight stud ends according to EN ISO 9974-2 type E. The countersink may, however, be deeper than specified in the standard.

▼ Porting pattern (example port plate 02)

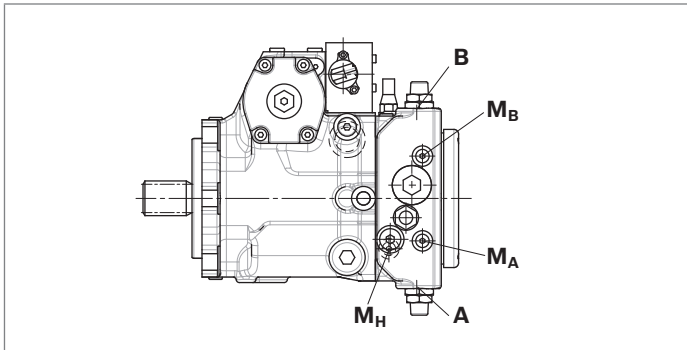

▼ Countersink of the measuring ports M_A , M_B and M_H

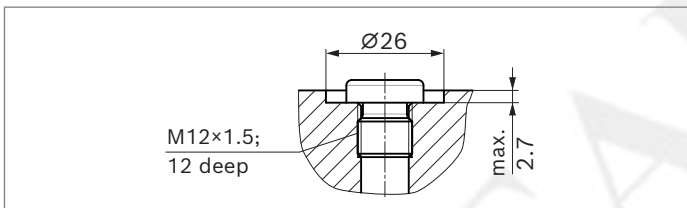

Working port (port plate) based on ISO 6149

The measuring ports M_A , M_B and are designed according to ISO 6149 and designed for straight stud ends according to EN ISO 6149-2. The countersink may, however, be deeper than specified in the standard.

▼ Porting pattern (example port plate 22)

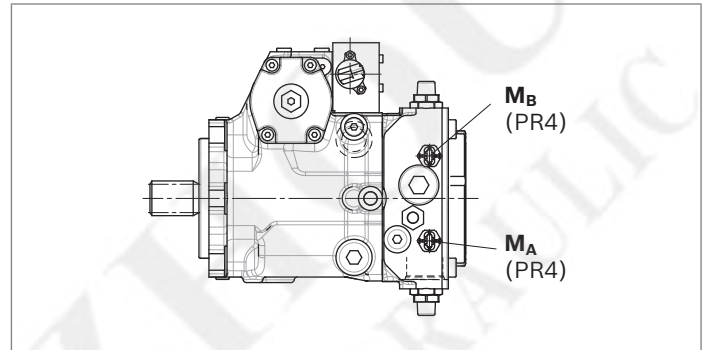

▼ Countersink of the measuring ports M_A , M_B

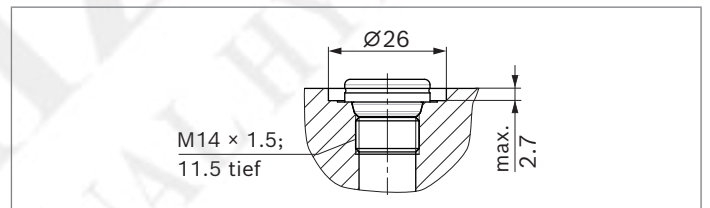

Filtration in the boost pump suction line

Version S

Filter version	Suction filter
Recommendation	With contamination indicator, with cold start valve
Recommended flow resistance at filter element	
At $v = 30 \text{ mm}^2/\text{s}$, $n = n_{\text{max}}$	$\Delta p = 0.1 \text{ bar}$
At $v = 1000 \text{ mm}^2/\text{s}$, $n = n_{\text{max}}$	$\Delta p = 0.3 \text{ bar}$
Pressure at suction port S	
Continuous $p_{S \text{ min}}$ ($v \leq 30 \text{ mm}^2/\text{s}$)	$\geq 0.8 \text{ bar absolute}$
Short-term, at a cold start ($t < 3 \text{ min}$)	$\geq 0.5 \text{ bar absolute}$
Maximum pressure $p_{S \text{ max}}$	$\leq 5 \text{ bar absolute}$

Use of version S is preferred.

The suction filter is not included in the scope of delivery.

▼ Circuit diagram¹⁾

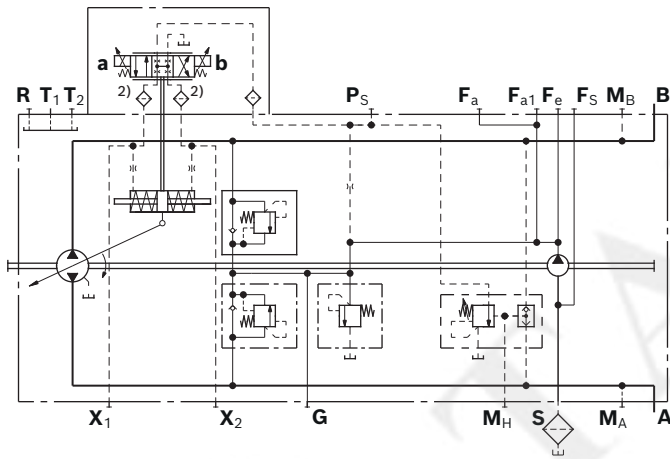

Filtration in the boost pump pressure line

Version D

Ports for external boost circuit filtration

Ports	
Boost pressure inlet	Port F_a
Boost pressure outlet	Port F_e
Filter version	Boost pressure filter
Recommendation	With contamination indicator, with cold start valve
Filter arrangement	Separate in the pressure line (inline filter)

The boost pressure filter is not included in the scope of delivery.

Notice

- ▶ Filters with a bypass are **not recommended**. Please contact us for applications with a bypass.
- ▶ On versions with DG control (with pilot pressure not from a boost circuit), a filter must be used that fulfills the requirements with regard to filtration of the hydraulic fluid (see page 7).
- ▶ The pressure drop at the filter is viscosity- and contamination-dependent. Note the maximum permissible pressure of the boost pump in combination with the set feed pressure.

▼ Circuit diagram¹⁾

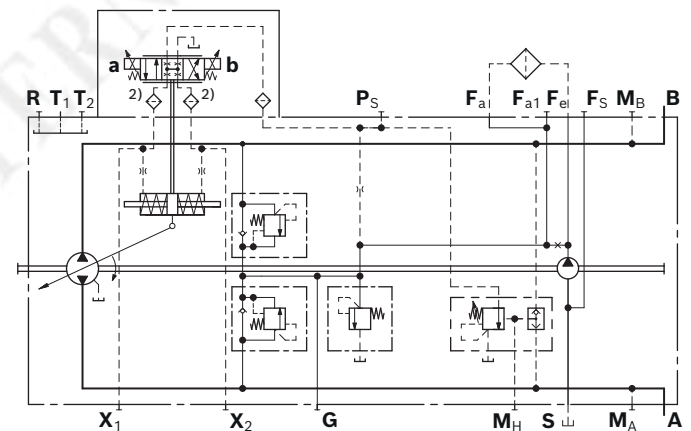

1) Size 28 without port F_{a1} and F_S

2) Only sizes 28 to 71 are designed with inlet filtration in X_1/X_2

▼ Dimensions of the countersinks F_e , F_{a1} , F_s

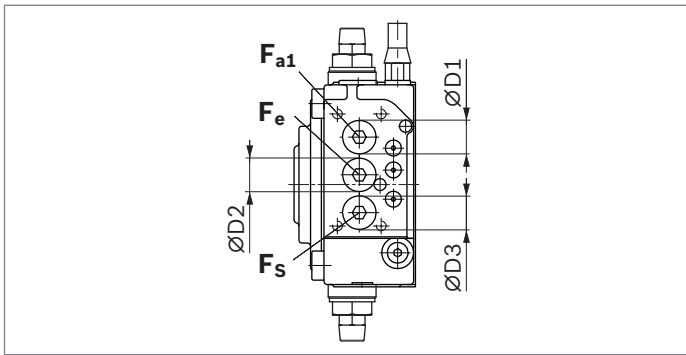

NG	ØD1	ØD2	ØD3
40	24 ^{+0.130} ₋₀	24 ^{+0.130} ₋₀	24 ^{+0.130} ₋₀
56	24 ^{+0.130} ₋₀	24 ^{+0.130} ₋₀	24 ^{+0.130} ₋₀
71	27.5 ^{+0.130} ₋₀	27.5 ^{+0.130} ₋₀	27.5 ^{+0.130} ₋₀
90	27.5 ^{+0.130} ₋₀	27.5 ^{+0.130} ₋₀	27.5 ^{+0.130} ₋₀
125	40 ^{+0.160} ₋₀	40 ^{+0.160} ₋₀	40 ^{+0.160} ₋₀
180	40 ^{+0.160} ₋₀	40 ^{+0.160} ₋₀	40 ^{+0.160} ₋₀

Version F¹⁾

Attachment filter with cold start valve

Filter version	Attachment filter
Recommendation	Version with contamination indicator, see P, B (differential pressure $\Delta p = 5$ bar)
Filter grade (absolute)	20 μ m
Filter material	Glass fiber
Pressure rating	100 bar
Filter arrangement	Mounted on pump

The attachment filter is equipped with a cold start valve and thereby protects the pump from damage. The valve opens at flow resistance of $\Delta p \geq 6$ bar.

Notice

The pressure drop at the filter is viscosity- and contamination-dependent. Note the maximum permissible pressure of the boost pump in combination with the set feed pressure.

▼ Filter characteristic curve

Differential pressure/flow behavior according to ISO 3968 (valid for non-contaminated filter element).

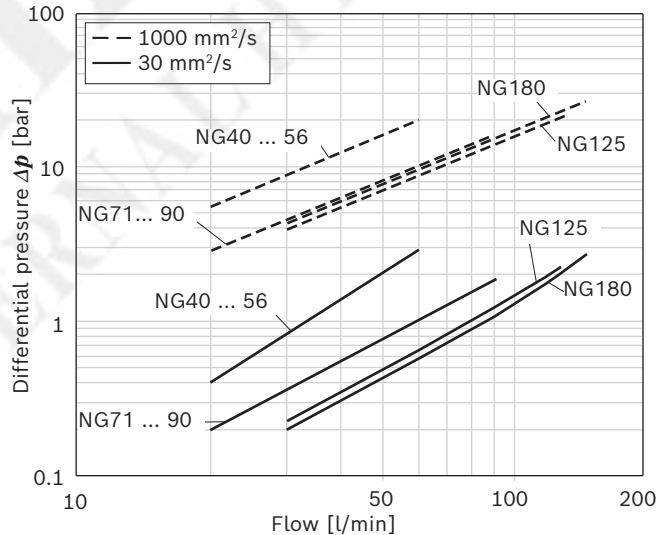

▼ Circuit diagram²⁾

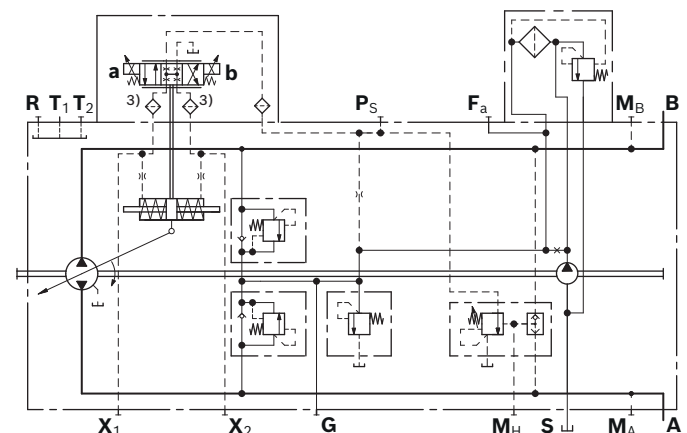

1) To protect the filter element against electrostatic charge buildup, the hydraulic fluid must have a minimum conductivity of 300 pS/m on versions with attachment filter F, P and B. Please contact us if this value cannot be observed.

2) Size 28 without port F_{a1} and F_s

3) Only sizes 28 to 71 are designed with inlet filtration in X_1/X_2

Version P¹⁾

Attachment filter with cold start valve and visual contamination indicator

Filtration similar to version F, however with additional visual contamination indicator.

Technical data	
Display type	Green/red window
Differential pressure (switching pressure)	$\Delta p = 5$ bar

▼ **Circuit diagram²⁾**

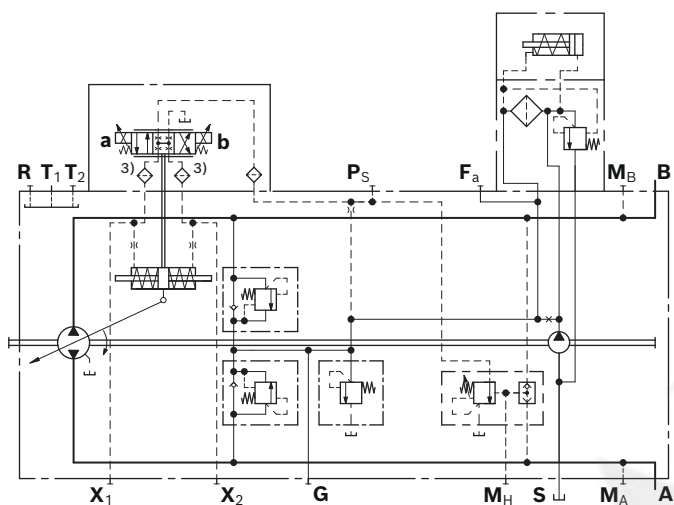

Version B¹⁾

Attachment filter with cold start valve and electric contamination indicator

Filtration similar to version F, however with additional electric contamination indicator.

Technical data	
Display type	Electric
Connector version (mating connector, see page 95)	DEUTSCH DT04-2P-EP04
Differential pressure (switching pressure)	$\Delta p = 5$ bar
Maximum switching capacity	12 V DC 24 W 24 V DC 48 W
Type of protection IP67	DIN/EN 60529

▼ **Circuit diagram²⁾**

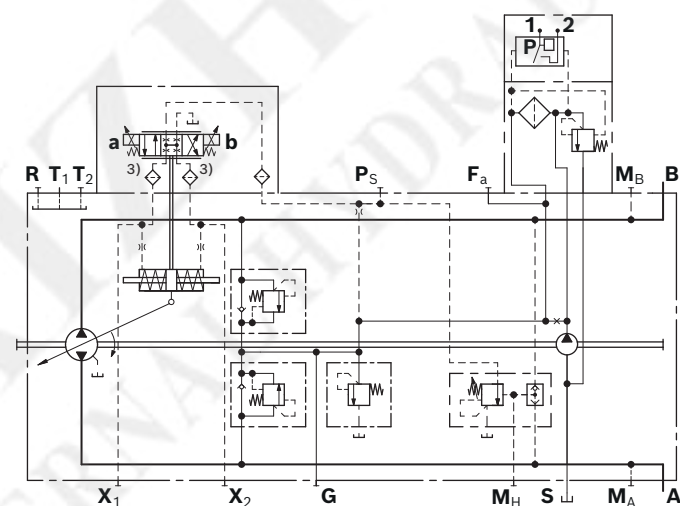

1) To protect the filter element against electrostatic charge buildup, the hydraulic fluid must have a minimum conductivity of 300 pS/m on versions with attachment filter F, P and B. Please contact us if this value cannot be observed.

2) Size 28 without port F_{a1} and F_S

3) Only sizes 28 to 71 are designed with inlet filtration in X_1/X_2

External boost pressure supply

Version E

This variation should be used in versions without integrated boost pump (**N** and/or **K**).

Port **S** is plugged.

The boost pressure supply comes from port **F_a**.

The filter should be installed separately on port **F_a** before the boost pressure supply.

To ensure the functional reliability, maintain the required cleanliness level for the boost fluid fed in at port **F_a** (see page 7).

▼ Circuit diagram¹⁾

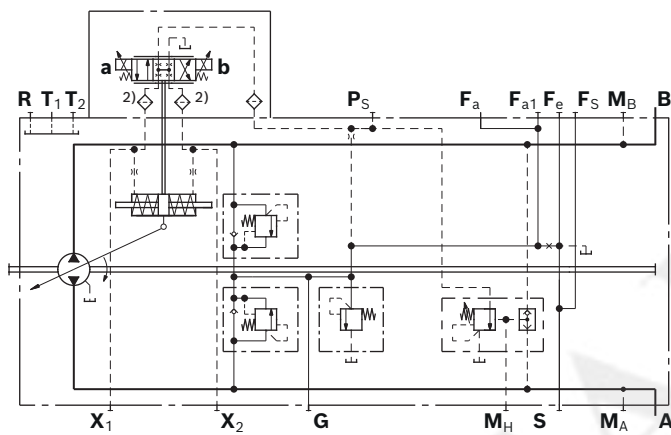

1) Size 28 without port **F_{a1}** and **F_s**

2) Only sizes 28 to 71 are designed with inlet filtration in **X₁/X₂**

Dimensions with mounted filter

▼ Version F

Attachment filter with cold start valve

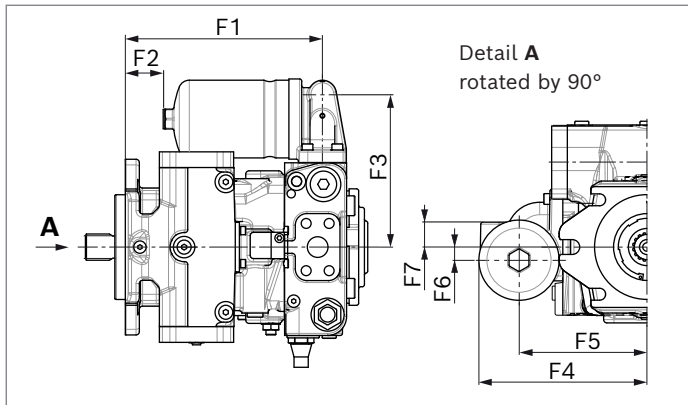

NG	F1	F2	F3	F4	F5	F6	F7	F8
40	201.7	47.7	160	175	135	0	42	78.5
56	218.4	64.4	163	178	138	0	42	78.5
71	239	46.5	185	203.5	155	16	29	65.5
90	248.5	56	179	197.5	149	0	45	81.5
125	235.9	59.4	201	219.5	171	0	53	89.5
180	279.9	40.3	202	220.4	171.9	17	36	72.5

▼ Version P

Attachment filter with cold start valve and visual contamination indicator

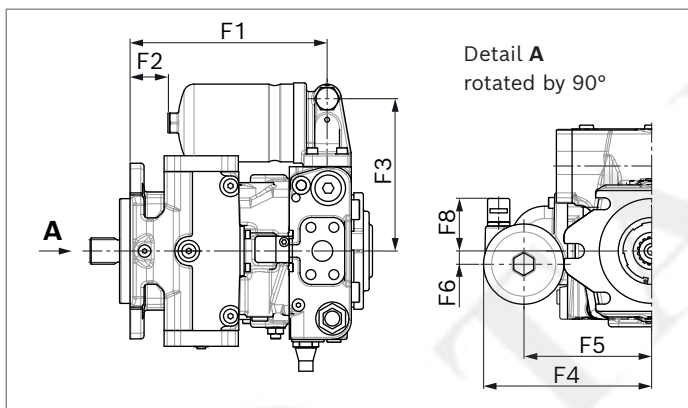

▼ Version B

Attachment filter with cold start valve and electric contamination indicator

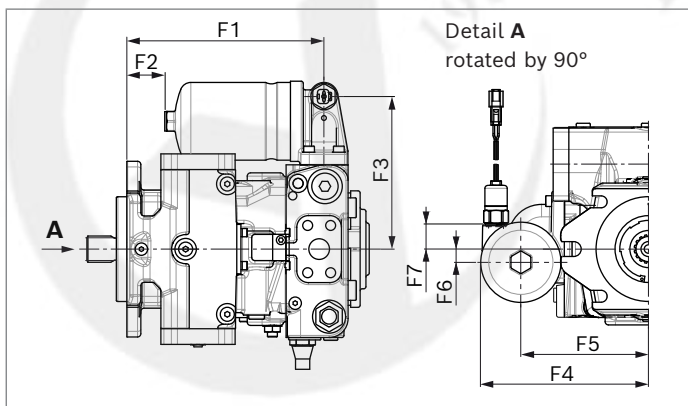

Connector for solenoids

DEUTSCH DT04-2P-EP04

- ▶ **P:** Molded, 2-pin, without bidirectional suppressor diode (standard).
- ▶ **Q:** Molded, 2-pin, with bidirectional suppressor diode (only for switching solenoids on control module EZ and DA)

The following type of protection ensues with the installed mating connector:

- ▶ IP67 (DIN/EN 60529) and
- ▶ IP69K (DIN 40050-9)

The protection circuit with bidirectional suppressor diode is needed to limit overvoltages. Overvoltages are caused by switching off the current with switches, relay contacts or by disconnecting the mating connector while voltage is applied.

▼ Switching symbol

Without bidirectional suppressor diode **With** bidirectional suppressor diode

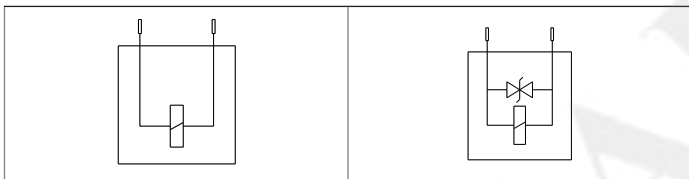

▼ Mating connector DEUTSCH DT06-2S-EP04

Consisting of	DT designation
1 housing	DT06-2S-EP04
1 wedge	W2S
2 sockets	0462-201-16141

The mating connector is not included in the scope of delivery. This can be supplied by We on request (material number R902601804).

Notice

- ▶ If necessary, you can change the position of the connector by turning the solenoid.
- ▶ The procedure is defined in the instruction manual.

Rotary inch valve

The rotary inch valve allows for any reduction of pilot pressure, independently of drive speed, through mechanical actuation of the control lever. The control lever is equipped with an internal rotational limiter $\pm 90^\circ$ (drawing item **1** and **2**).

The valve is arranged separately from the pump and is connected to the pump by a hydraulic control line via port **P_S** (maximum line length: approx. 2 m).

The rotary inch valve must be ordered separately.

NG	Material number	Direction of actuation of the control lever	Throttle cross-section \varnothing
28, 40,	R902048734	Clockwise	4.6
56, 71, 90	R902048735	Counter-clockwise	4.6
	R902070172	Clockwise	2.7
	R902066994	Counter-clockwise	2.7
125	R902048740	Clockwise	4.7
	R902048741	Counter-clockwise	4.7

Notice

The rotary inch valve can be used regardless of the control module. If necessary, the position of the control lever can be changed.

▼ Circuit diagram

Hydraulic control, speed related

DA with separately attached rotary inch valve

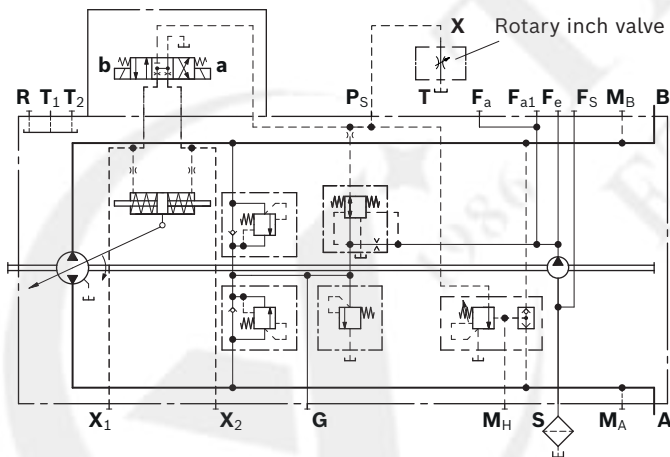

Dimensions

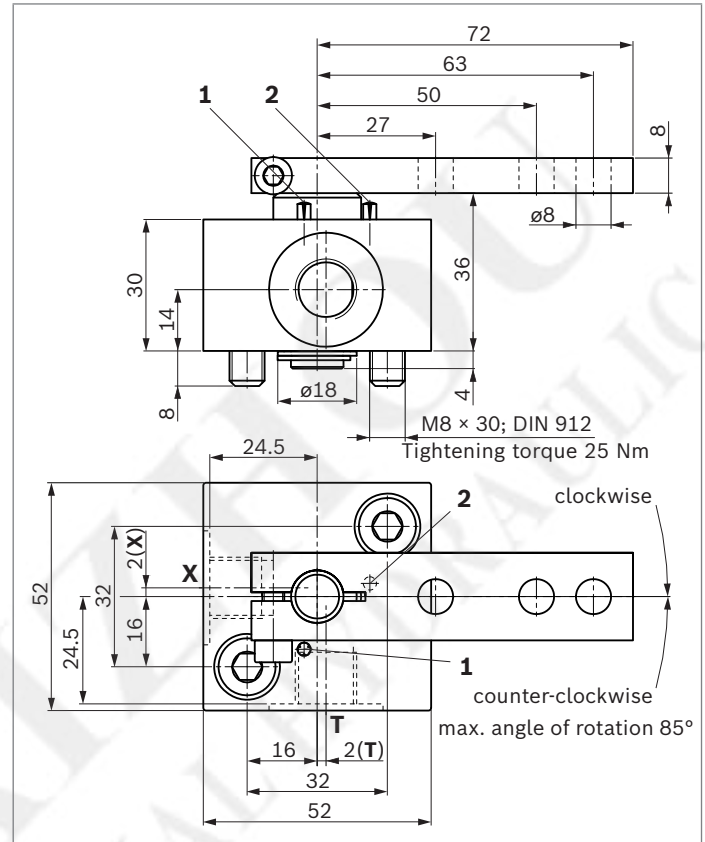

Notice

To prevent damage to the rotary inch valve, a positive mechanical stop of $\pm 85^\circ$ must be provided for the control lever on the customer side.

Ports	Standard ¹⁾	Size	p_{\max} [bar] ²⁾	State ³⁾
X Pilot pressure port	DIN 3852	M14 x 1.5; 12 deep	40	O
T Drain port	DIN 3852	M14 x 1.5; 12 deep	3	O

1) The countersink may be deeper than specified in the standard.

Ports designed for straight stud ends according to EN ISO 9974-2 type E.

2) Depending on the application, momentary pressure peaks can occur. Keep this in mind when selecting measuring devices and fittings.

3) O = Must be connected (plugged on delivery)

Installation dimensions for coupling assembly

To ensure that rotating components (coupling hub) and fixed components (housing, retaining ring) do not come into contact with each other, the installation conditions described here must be observed. This depends on the pump size and the splined shaft.

SAE splined shaft (spline according to ANSI B92.1a)

Splined shaft **S** and/or **T**

The outer diameter of the coupling hub must be smaller than the inner diameter of the retaining ring (dimension d_2) in the area near the drive shaft collar (dimension $x_2 - x_3$). Observe diameter of relief on sizes 28 and 40.

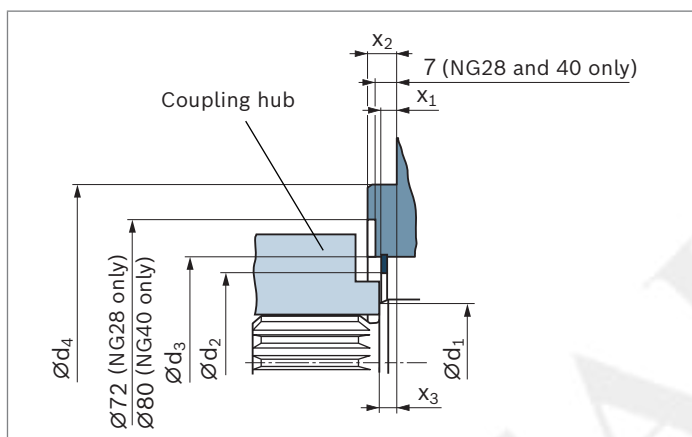

DIN splined shaft (spline according to DIN 5480)

Splined shaft **Z** or **A**

The outer diameter of the coupling hub must be smaller than the case diameter d_3 in the area near the drive shaft collar (dimension $x_2 - x_4$).

Observe diameter of relief on sizes 28 and 40.

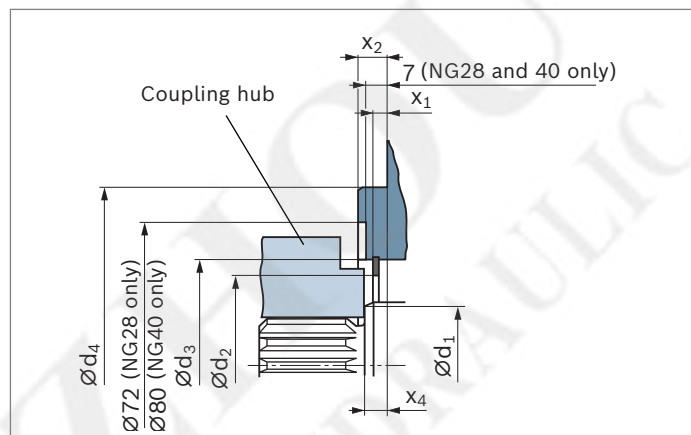

NG	Ød ₁ SAE splined shaft	Ød ₁ DIN splined shaft	Ød ₂ min	Ød ₃	Ød ₄	x ₁	x ₂	x ₃	x ₄
28	33.5	32.1	43.4	55±0.1	101.6 ₀ -0.054	3.3+0.2	9.5-0.5	8 +0.9 -0.6	10 +0.9 -0.6
40	38.5	37.1	51.4	63±0.1	127 ₀ -0.063	4.3+0.2	12.7-0.5	8 +0.9 -0.6	10 +0.9 -0.6
56	38.5	37.1	54.4	68±0.1	127 ₀ -0.063	7.0+0.2	12.7-0.5	8 +0.9 -0.6	10 +0.9 -0.6
71	43.5	42.1	66.5	81±0.1	127 ₀ -0.063	7.0+0.2	12.7-0.5	8 +0.9 -0.6	10 +0.9 -0.6
90	48.5	47.1	66.5	81±0.1	152.4 ₀ -0.063	6.8+0.2	12.7-0.5	8 +0.9 -0.6	10 +0.9 -0.6
125	53.5	52.1	76.3	91±0.1	152.4 ₀ -0.063	7.0+0.2	12.7-0.5	8 +0.9 -0.6	10 +0.9 -0.6
180	58.5	57.1	88	107±0.1	165.1 ₀ -0.063	7.4+0.2	15.9-0.5	8 +0.9 -0.6	10 +0.9 -0.6

Installation instructions

General

The axial piston unit must be filled with hydraulic fluid and air bled during commissioning and operation. This must also be observed following a longer standstill as the axial piston unit may empty via the hydraulic lines.

Particularly in the installation position "drive shaft upwards", filling and air bleeding must be carried out completely as there is, for example, a danger of dry running.

The leakage in the housing area must be directed to the reservoir via the highest drain port (**T₁**, **T₂**). For combination pumps, the leakage must be drained off at each single pump. If a shared drain line is used for several units, make sure that the respective case pressure in each unit is not exceeded. The shared drain line must be dimensioned to ensure that the maximum permissible case pressure of all connected units is not exceeded in any operating condition, particularly at cold start. If this is not possible, separate drain lines must be laid, if necessary.

To achieve favorable noise values, decouple all connecting lines using elastic elements and avoid above-reservoir installation.

Under all operating conditions, the suction line and drain line must flow into the reservoir below the minimum fluid level. The permissible suction height h_s results from the total pressure loss; it must not, however, be higher than $h_{s \max} = 800 \text{ mm}$.

The suction pressure at port **S** must also not fall below the minimum value of 0.8 bar absolute during operation (cold start 0.5 bar absolute).

When designing the reservoir, ensure that there is adequate distance between the suction line and the drain line.

We recommend using a baffle (baffle plate) between suction line and drain line. A baffle improves the air separation ability as it gives the hydraulic fluid more time for desorption.

Apart from that, this prevents the heated return flow from being drawn directly back into the suction line. The suction port must be supplied with air-free, calmed and cooled hydraulic fluid.

Installation position

See the following examples 1 to 12.

Further installation positions are available upon request. Recommended installation position: 1 and 2.

Notice

► Size 71 to 180

With the "drive shaft upwards" installation position, an **R₁** port is necessary (special version).

► If filling the stroking chambers via **X₁** to **X₄** is not possible in the final installation position, then this must take place before installation, e. g. in installation position 2.

► To prevent unexpected actuation and damage, the stroking chambers must be air bled via the ports **X₁**, **X₂**, or **X₃**, **X₄** depending on the installation position.

► In certain installation positions, an influence on the adjustment or control can be expected. Gravity, dead weight and case pressure can cause minor characteristic shifts and changes in response time.

Below-reservoir installation (standard)

Below-reservoir installation means that the axial piston unit is installed outside of the reservoir below the minimum fluid level of the reservoir.

Installation position	Air bleed the housing	Air bleed the stroking chamber	Filling
1	F ₁ , R	X ₁ , X ₂	S + T ₁ + X ₁ + X ₂

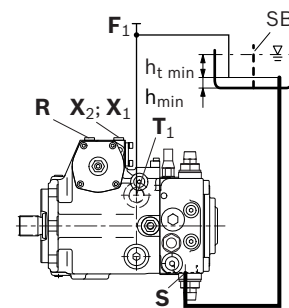

2	F ₁	-	S + T ₂
---	----------------	---	--------------------

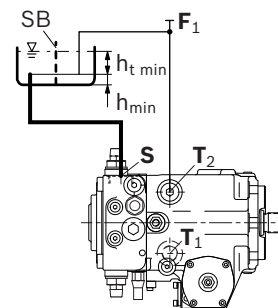

Installation position	Air bleed the housing	Air bleed the stroking chamber	Filling
3	F ₁	X ₁ , X ₂	S + T ₂ + X ₁ + X ₂

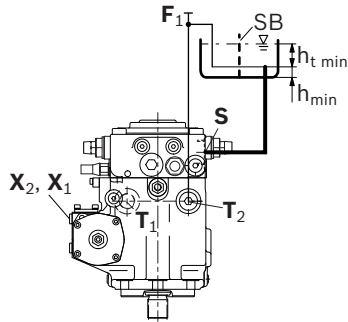

4	F ₁ , R ₁	X ₃ , X ₄	S + T ₂ + X ₃ + X ₄
---	---------------------------------	---------------------------------	--

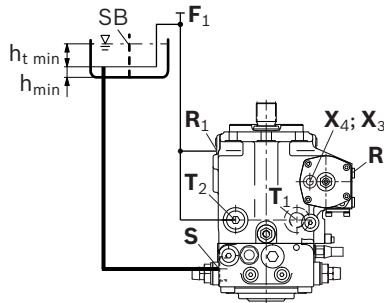

5	F ₁	X ₃	S + T ₁ + X ₃
---	----------------	----------------	-------------------------------------

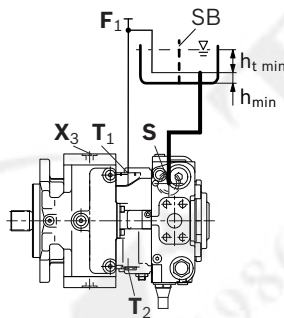

6	F ₁	X ₄	S + T ₂ + X ₄
---	----------------	----------------	-------------------------------------

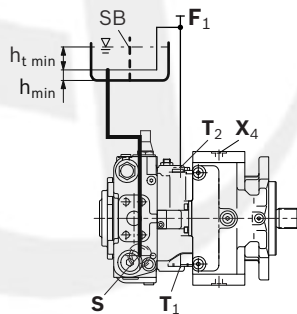

Above-reservoir installation

Above-reservoir installation means that the axial piston unit is installed above the minimum fluid level of the reservoir.

Observe the maximum permissible suction height $h_{S \max} = 800 \text{ mm}$.

Recommendation for installation position 10 (drive shaft upward): A check valve in the drain line (cracking pressure 0.5 bar) can prevent the housing area from draining.

Installation position	Air bleed the housing	Air bleed the stroking chamber	Filling
7	F ₁ + R	X ₁ , X ₂	F ₁ + F ₂ + X ₁ + X ₂

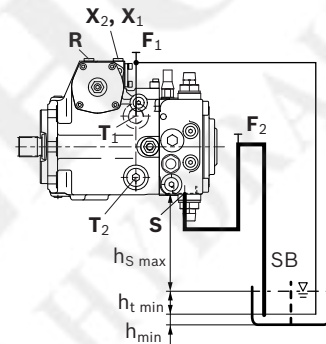

8	F ₁ (T ₂) + F ₂ (S) -		F ₂ (S) + F ₁ (T ₂)
---	---	--	---

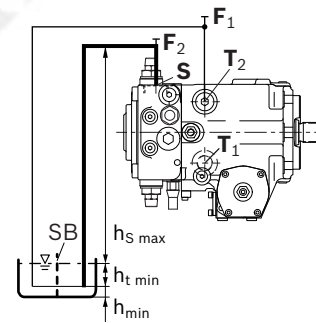

9	F ₂ (S) + F ₁ (T ₂)	X ₁ , X ₂	F ₂ (S) + F ₁ (T ₂) + X ₁ + X ₂
---	---	---------------------------------	---

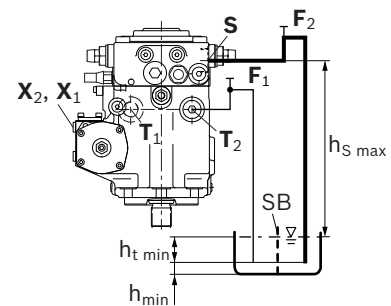

Installation position	Air bleed the housing	Air bleed the stroking chamber	Filling
10	$F_1 + R_1$	X_3, X_4	$F_1 + F_2 + X_3 + X_4$

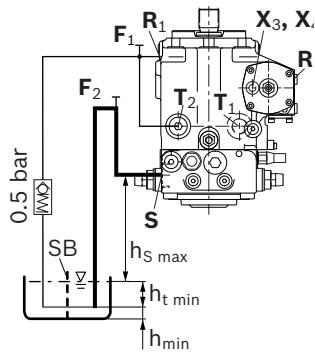

11	$F_1 (T_1) + F_2 (S)$	X_3	$F_2 (S) + F_1 (T_1) + X_3$
----	-----------------------	-------	-----------------------------

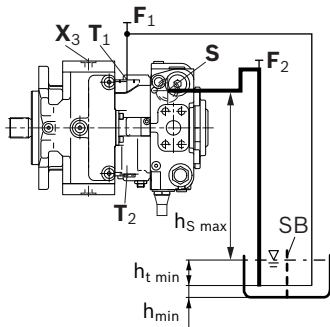

12	$F_1 (T_2) + F_2 (S)$	X_4	$F_2 (S) + F_1 (T_2) + X_4$
----	-----------------------	-------	-----------------------------

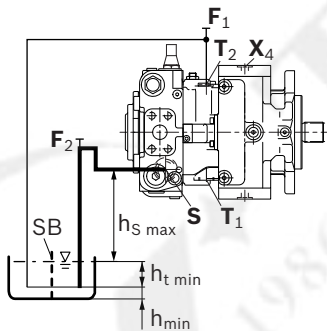

Key	
F_1, F_2	Filling/air bleeding
R	Air bleed port
R_1	Air bleed port (special version)
S	Suction port
T_1, T_2	Drain port
X_1, X_2	Control pressure port
X_3, X_4	Stroking chamber pressure port
SB	Baffle (baffle plate)
$h_{t \min}$	Minimum required immersion depth (200 mm)
h_{\min}	Minimum required distance to reservoir bottom (100 mm)
$h_{S \max}$	Maximum permissible suction height (800 mm)

Notice

Ports F_1 and F_2 are part of the external piping and must be provided on the customer side to make filling and air bleeding easier.

Project planning notes

- ▶ The pump is designed to be used in a closed circuit.
- ▶ The project planning, installation and commissioning of the axial piston unit requires the involvement of skilled personnel.
- ▶ Before using the axial piston unit, please read the corresponding instruction manual completely and thoroughly.
- ▶ Before finalizing your design, please request a binding installation drawing.
- ▶ The specified data and notes contained herein must be observed.
- ▶ Depending on the operating conditions of the axial piston unit (working pressure, fluid temperature), the characteristic curve may shift.
- ▶ Preservation: Our axial piston units are supplied as standard with preservation protection for a maximum of 12 months. If longer preservation protection is required (maximum 24 months), please specify this in plain text when placing your order. The preservation periods apply under optimal storage conditions, details of which can be found in the data sheet 90312 or the instruction manual.
- ▶ Not all versions of the product are approved for use in a safety function according to ISO 13849. Please consult the responsible contact person at We if you require reliability parameters (e.g. $MTTF_D$) for functional safety.
- ▶ Depending on the type of control used, electromagnetic effects can be produced when using solenoids. Applying a direct voltage signal (DC) to solenoids does not create electromagnetic interference (EMI) nor is the solenoid affected by EMI. Electromagnetic interference (EMI) potential exists when operating and controlling a solenoid with a modulated direct voltage signal (e.g. PWM signal) Appropriate testing and measures should be taken by the machine manufacturer to ensure other components or operators (e.g. with pacemaker) are not affected by this potential.
- ▶ The pressure cut-off is not a safeguard against pressure overload. Be sure to add a pressure relief valve to the hydraulic system.
- ▶ With dynamic power flow (change of pumps to operation as a motor) a maximum of 95% $V_{g \max}$ is permissible. We recommend configuring the software accordingly.
- ▶ Please note that a hydraulic system is an oscillating system. This can lead, for example, to the stimulation the natural frequency within the hydraulic system during operation at constant rotational speed over a long period of time. The stimulator frequency of the pump is 9 times the rotational speed frequency. This can be prevented, for example, with suitably designed hydraulic lines.
- ▶ Please note the details regarding the tightening torques of port threads and other threaded joints in the instruction manual.
- ▶ The ports and fastening threads are designed for the p_{\max} permissible pressures of the respective ports, see the connection tables. The machine or system manufacturer must ensure that the connecting elements and lines correspond to the specified application conditions (pressure, flow, hydraulic fluid, temperature) with the necessary safety factors.
- ▶ The service ports and function ports are only intended to accommodate hydraulic lines.

Safety instructions

- ▶ During and shortly after operation, there is a risk of burns on the axial piston unit and especially on the solenoids. Take the appropriate safety measures (e.g. by wearing protective clothing).
- ▶ Moving parts in control equipment (e.g. valve spools) can, under certain circumstances, get stuck in position as a result of contamination (e.g. contaminated hydraulic fluid, abrasion, or residual dirt from components). As a result, the hydraulic fluid flow and the build-up of torque in the axial piston unit can no longer respond correctly to the operator's specifications. Even the use of various filter elements (external or internal flow filtration) will not rule out a fault but merely reduce the risk.

The machine/system manufacturer should test whether additional measures are required on the machine for the relevant application in order to bring the driven consumer into a safe position (e.g., safe stop) and make sure any measures are properly implemented.

- ▶ Moving parts in high-pressure relief valves may in certain circumstances become stuck in an undefined position due to contamination (e.g. impure hydraulic fluid). This can result in restriction or loss of load-holding functions in lifting winches.

The machine/system manufacturer must check whether additional measures are required on the machine for the relevant application in order to keep the load in a safe position and ensure they are properly implemented.