

Hydraulic Brake

BK2 Series Brake

Part Number	Min Op Pres	Max Pressure	Shaft	Min Static Tq
BK2-1-430-CCB	17-23 Bar	300 Bar	1.0" Keyed	430 Nm

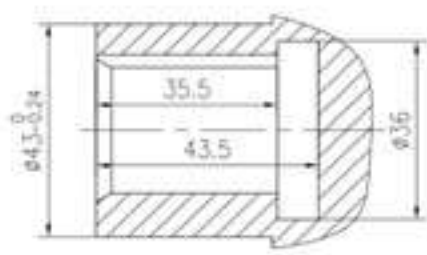

Input Shaft

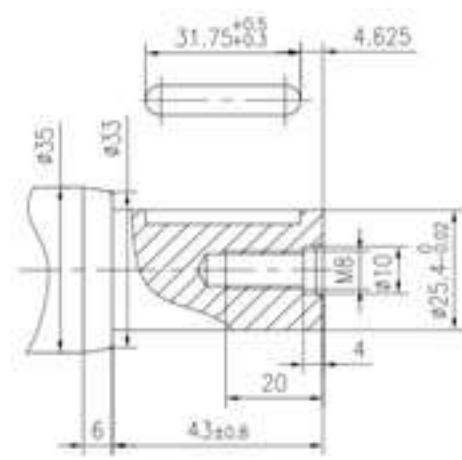
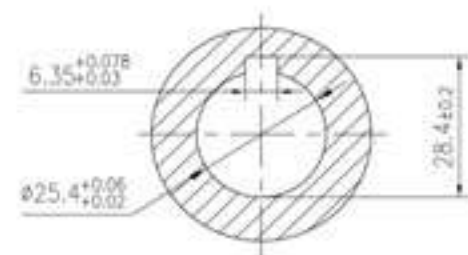

Output Shaft

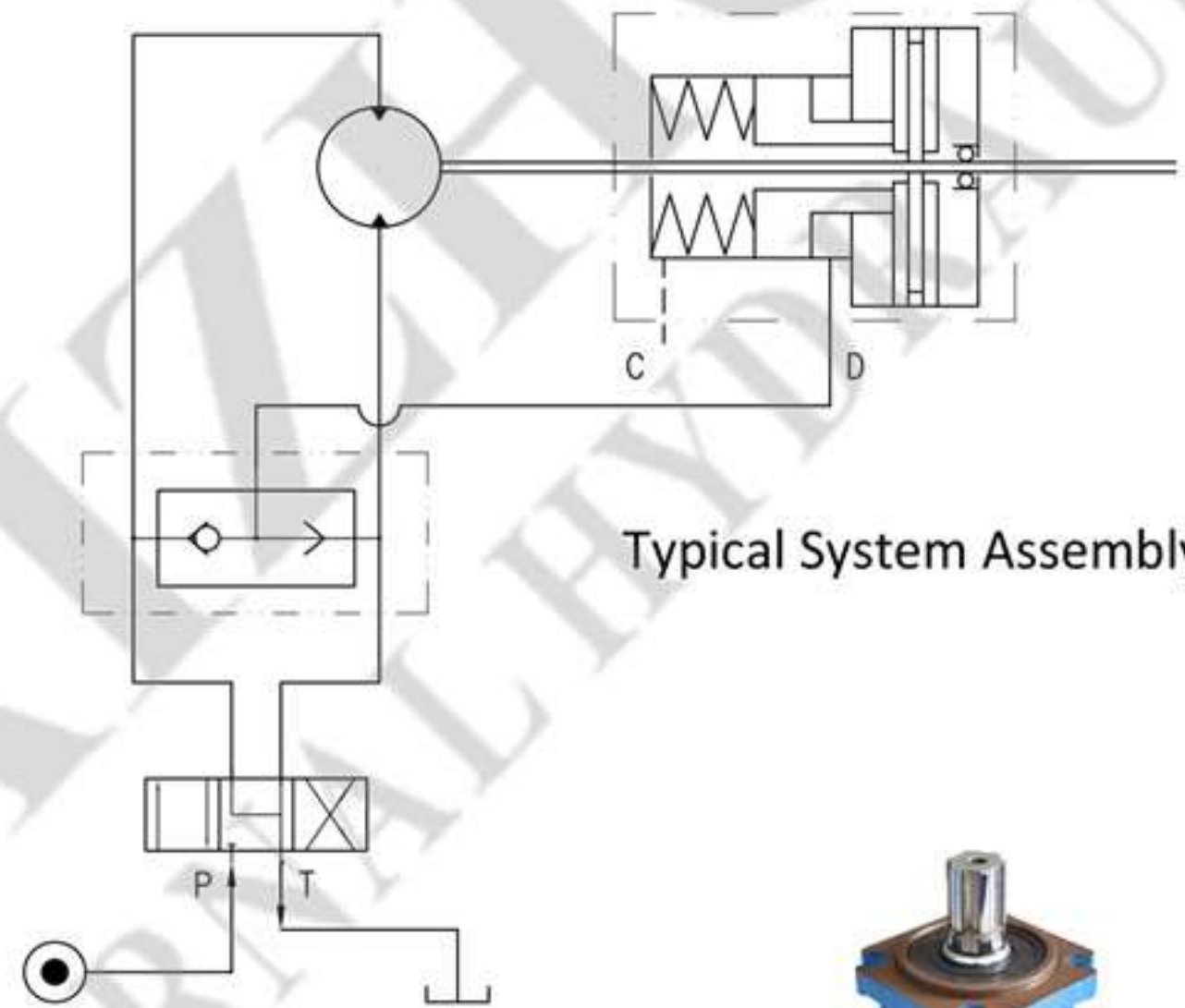
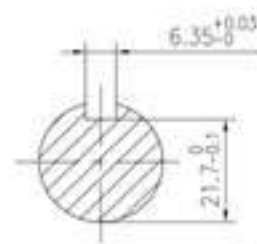

Typical System Assembly

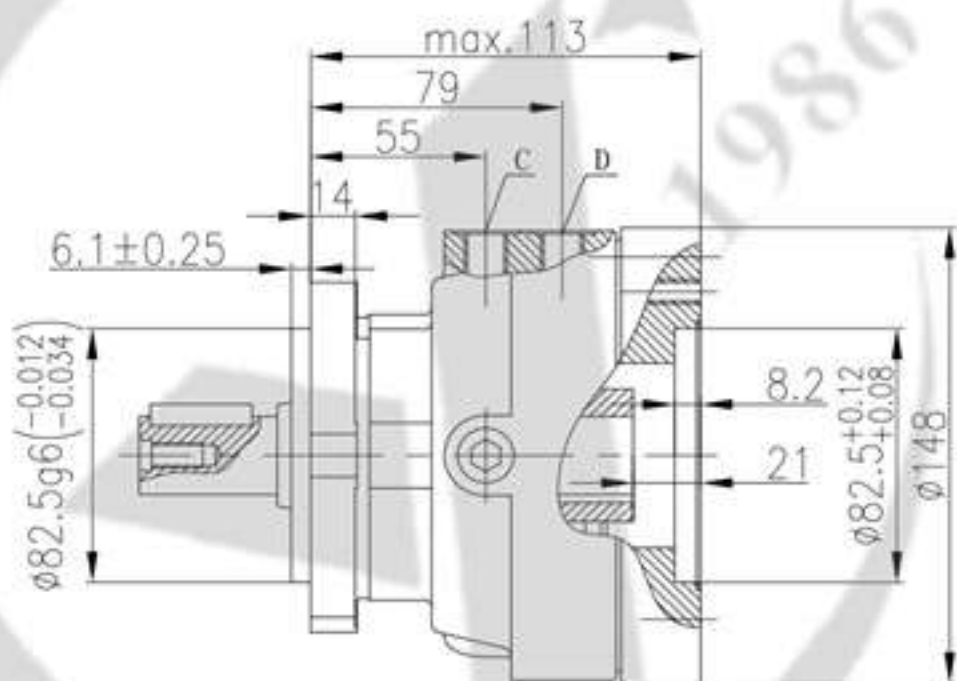

Dimensions

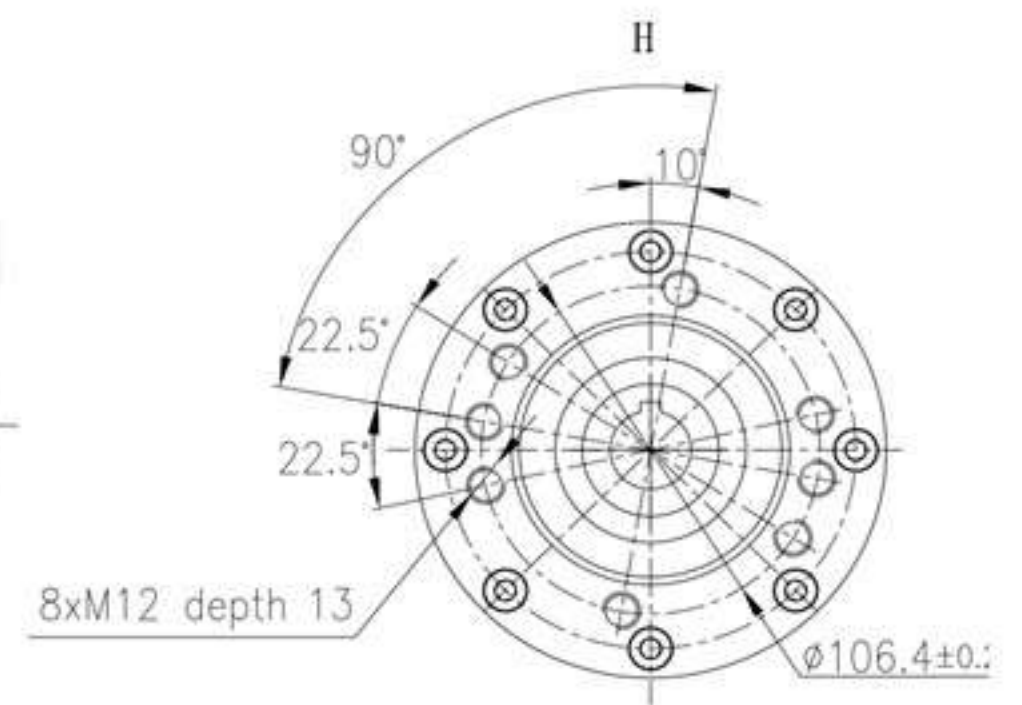



BK2 SERIES HYDRAULIC BRAKE

Introduction

BK2 series brake is one kind of hydraulic wet disc brake. The brake force is caused by the spring, and hydraulic pressure releases the brake force.

Features as follows:

- * BK2 series adopts the special friction disc and high strength spring design: long life endurance, low noise, high braking reliability.
- * with 4 Drain port design, the brake can be used in different applications.
- * compact structure, easy mounting.
- * it can be used preferentially together with BMP, BMR, BMS series hydraulic motor.

Application

BK2 series hydraulic brake stays in braking condition since delivery out of the factory. During normal operation, there exists the braking force in the brake disc, only if the pressure of hydraulic system, that the brake links, is lower than the pressure required by the release of brake, the spring force shall keep the brake in braking condition.

BK2 series hydraulic brake is widely used in heavy duty machinery, such as engineering machinery, cranes, off-highway machinery vehicles, construction machinery, material handling machinery, agricultural machinery, mining, sanitation machinery, timber industries. They are also used in winches and in hydrostatic drive systems for automatization engines.

Special Note: such kind of brake is only used in static parking brake. Dynamic braking is not recommended.

Intruction Manual

—、 In order to make the BK2 series brake work under the best situation, we recommend the normal requirements as follows:

- 1.Assembly: 1st of all, we have to mount the brake BK2 with hydraulic motor, and then fill the brake with lubrication oil through the drain port, and then mount with other parts.
- 2.Fluid type: Mineral based-HM(GB/T763.2-87) (ISO6743/4) or HLP(DIN51524).
- 3.Temperature range:normal -20°C – 90°C the best optimal situation 20°C – 60°C
- 4.Viscosity range: $20\sim 75\text{mm}^2/\text{s}$; the best optimal situation $42\sim 74\text{mm}^2/\text{s}$ at 40°C .
- 5.Filtration: nominal filtration of 25 micron, ISO code 20/16.
- 6.Maintenance: changed after the first 50~100h; then after every 500~1000h.

Typical Applications Drawing

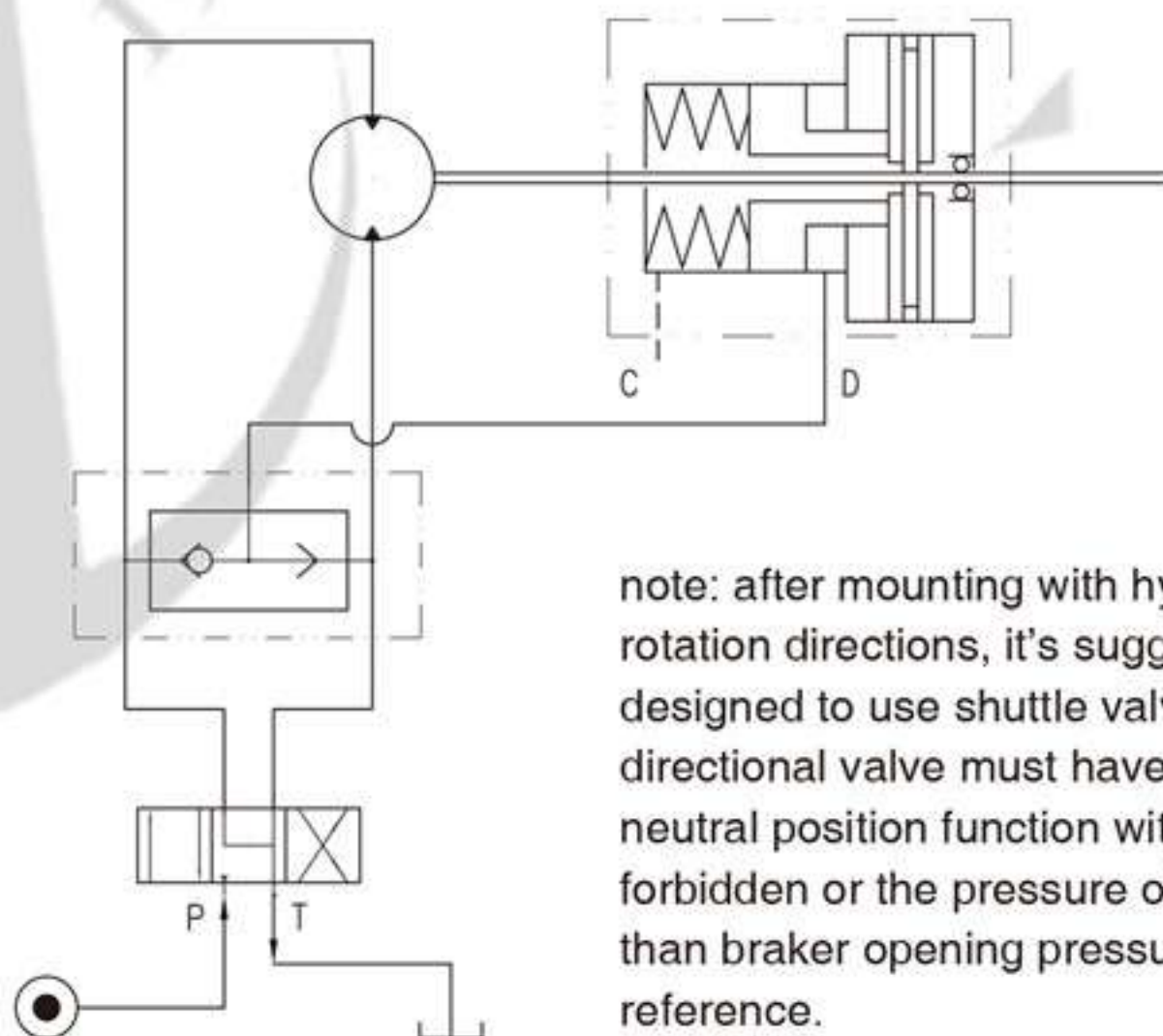

note: after mounting with hydraulic motor, if the motor needs both rotation directions, it's suggested that the hydraulic system is designed to use shuttle valve, and the neutral position of the directional valve must have off-load function(type Y or H), the neutral position function without off-load function (type O) is forbidden or the pressure of the outlet port in the system is larger than braker opening pressure. Please check the drawing for reference.

Specification Data

Item	BK2-1	BK2-2
Min. static Torque [Nm]	200~230	410~450
Min. Opening Pressure [MPa]	1.7~2.3	
Max. Opening Pressure [MPa]	30	
Min. oil quantity for brake releasing [cm ³]	7~8	
Oil volume [cm ³]	50~120	
Max. pressure in drain space [MPa]	0.05	
Weight [kg]	9	9.5

*Static torque is obtained at working pressure 0 MPa

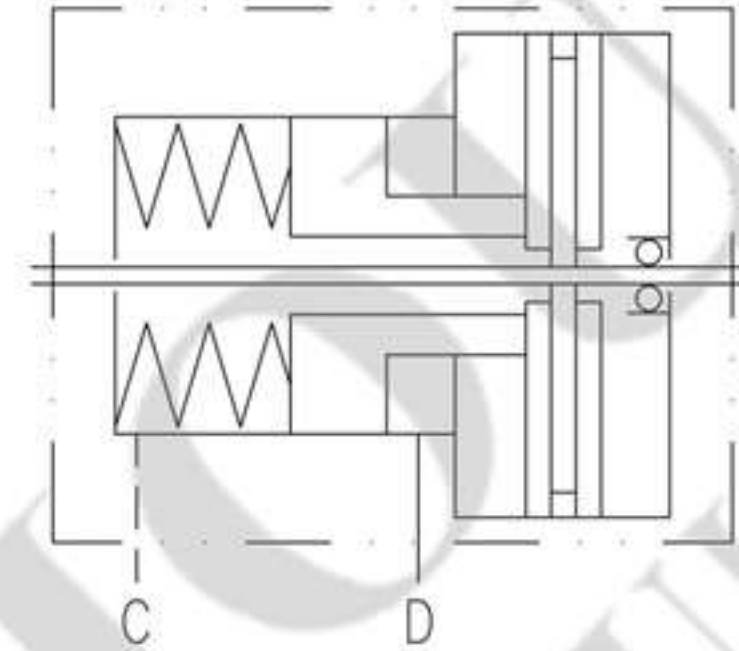

symble drawing

Load Curve

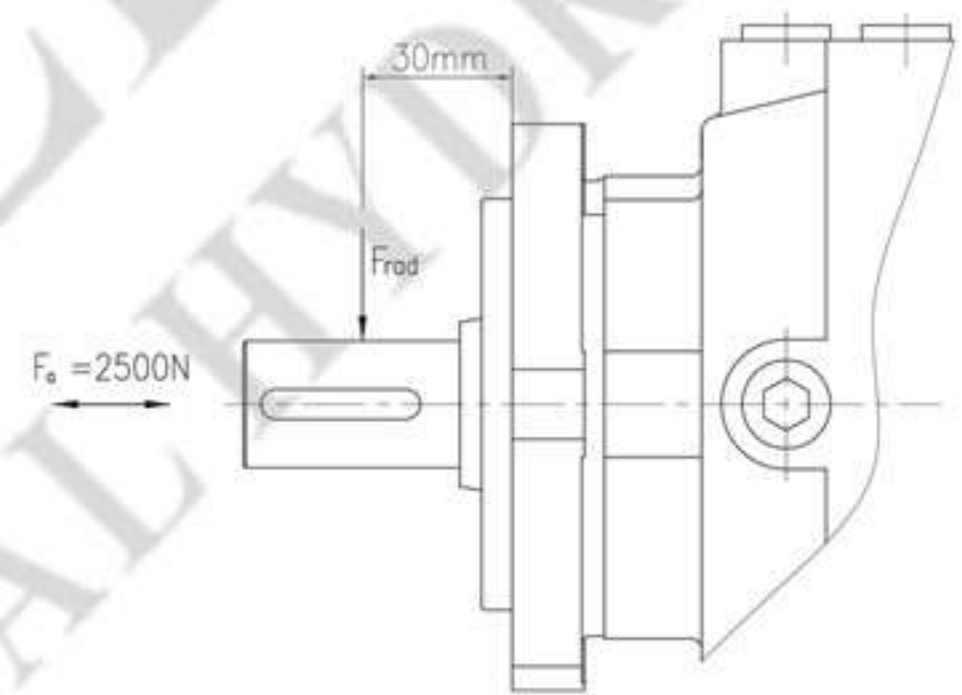
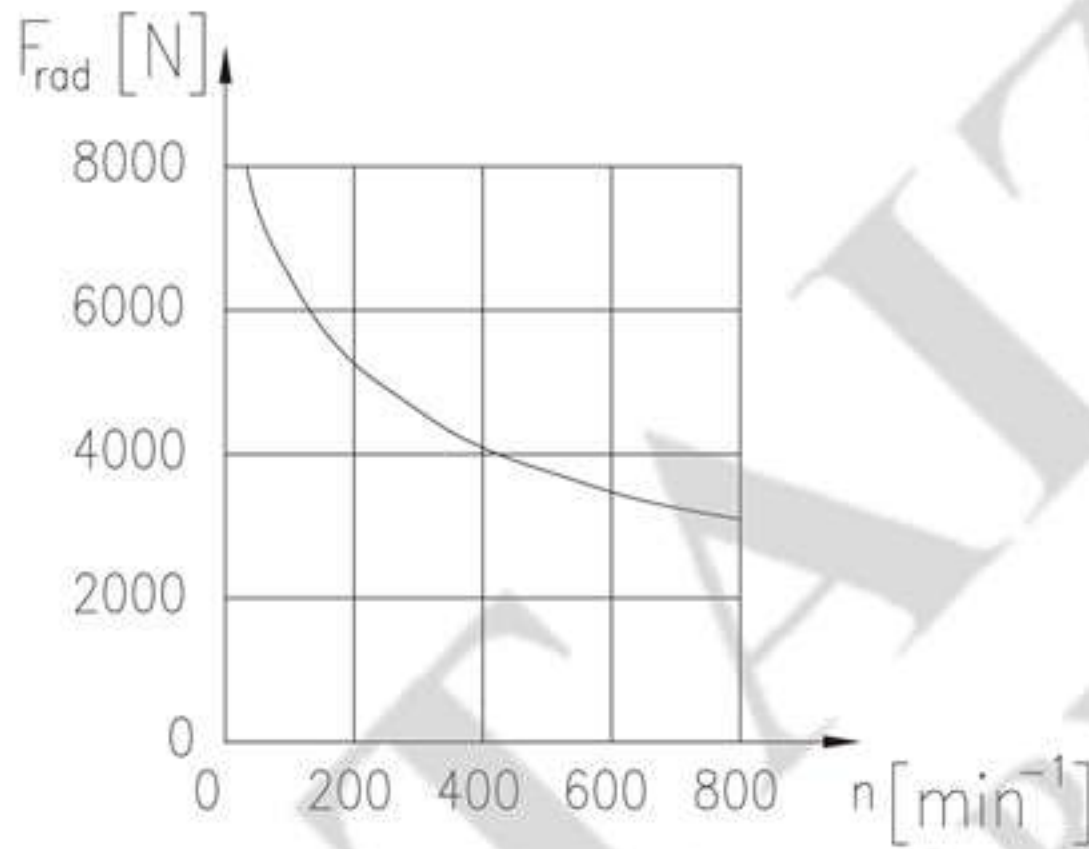

Mounting Data Model BK2-1

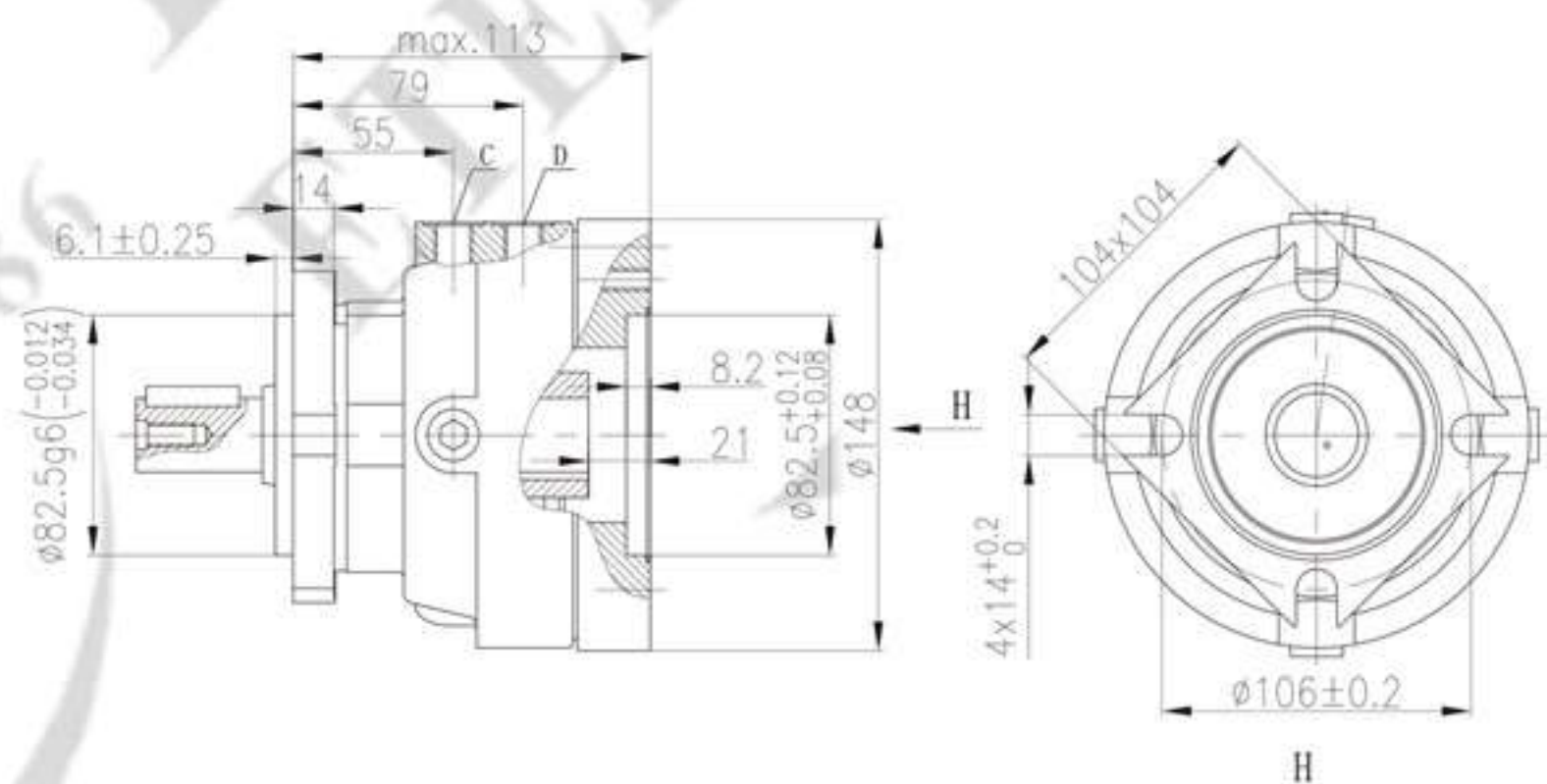

C Drain port—G1/4, 9mm depth; Infuse port in the housing
D Brake release port—G1/4, 9mm depth

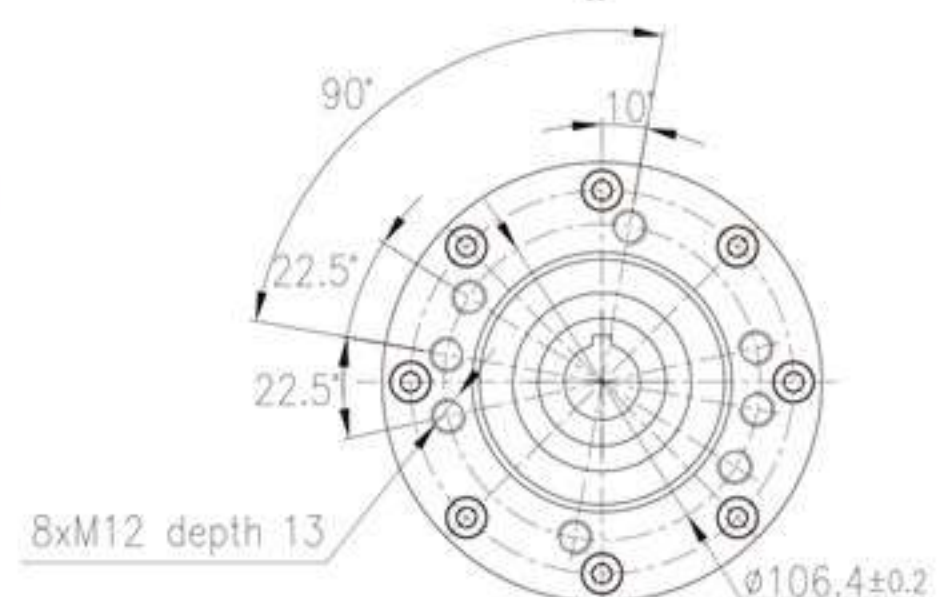

BK2系列液压制动器 BK2 Series Hydraulic Brake

Model BK2-2

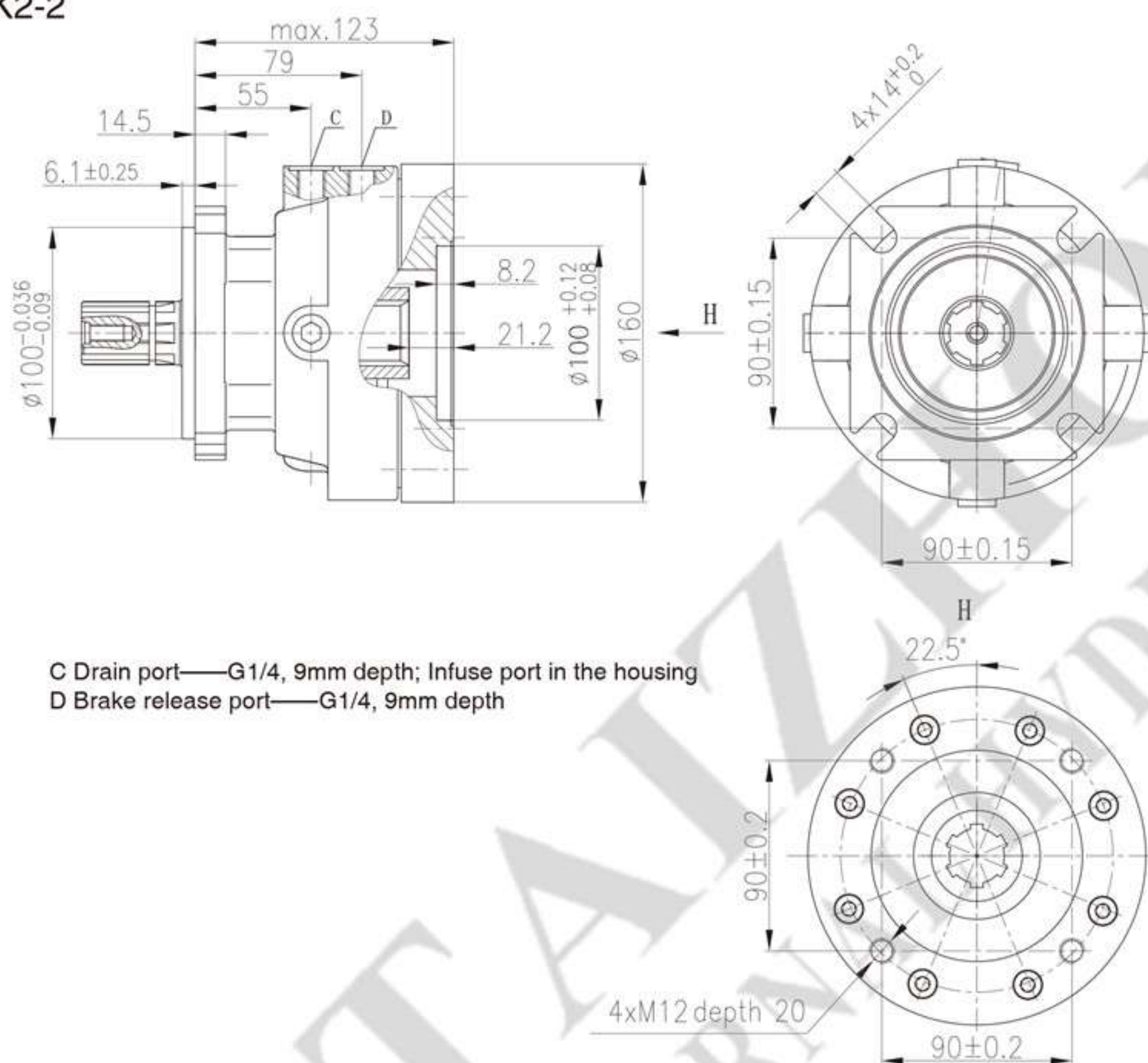

C Drain port—G1/4, 9mm depth; Infuse port in the housing
D Brake release port—G1/4, 9mm depth

INPUT & OUTPUT SHAFT DATA
INPUT SHAFT HOLES

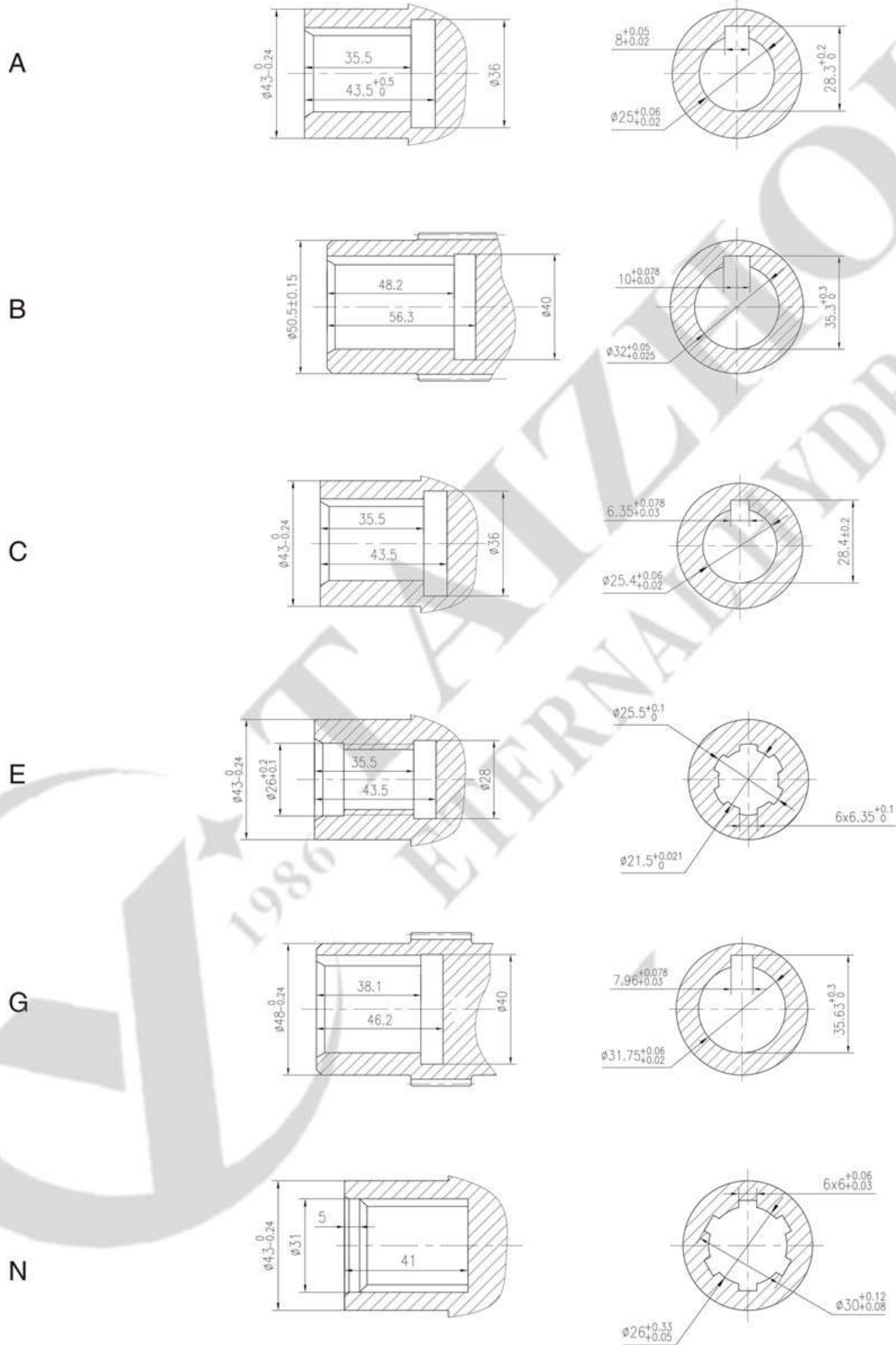

Order Information

1	2	3	4	5	6	7
BK	-	-	-	-	-	-

Pos.1	2	3	4	5	6	7
Series Code	Structure Code	Torque	Input Shaft holes	Output Shaft extensions	Paint	Unusually function
2	1	Torque200--230Nm	Shaft holes Φ 25, Parallel key 8x7x32 Shaft holes Φ 32, Parallel key 10x8x45 Shaft holes Φ 25.4, Parallel key 6.35x6.35x31.75	A Shaft Φ 25, Parallel key 8x7x32 B Shaft Φ 32, Parallel key 10x8x45 C Shaft Φ 25.4, Parallel Key 6.35x6.35x31.75	No Paint Blue Black Silver Grey	00 omit B S Standard omit
		Torque410--450Nm	Shaft holes Φ 25.4, splined key SAE 6B Shaft holes Φ 31.75, Parallel key 7.96x7.96x31.75 Shaft holes Splined 6-30x26x6 Shaft holes Splined 6-30x26x8	A Shaft Φ 25.4, splined key SAE 6B E Shaft Φ 25.4, splined key SAE 6B G Shaft Φ 31.75, Parallel Key 7.96x7.96x31.75 N Shaft Splined 6-30x26x6 J Shaft Splined 6-30x26x8	No Paint Blue Black Silver Grey	00 omit B S Standard omit
	2	Torque410--450Nm	Shaft holes Splined 6-30x26x6 Shaft holes Splined 6-30x26x8	N Shaft Splined 6-30x26x6 J Shaft Splined 6-30x26x8	No Paint Blue Black Silver Grey	00 omit B S Standard omit

Note: When the table is used, pls fill the code with right rows in the table and give us, which the code information is consist of construction, torque, input Shaft holes, output Shaft extensions, Paint .If the specification is not in the table or you have specific requirements, please contact us.