

1,2,3 Product Series

PVM – M Series Variable Piston Pump

4,5,6 Displacement

Twelve displacements available 230 bar and 315 bar continuous ratings
See page 6

7 Valve Plate

E - Quiet version, optimized for 1000-1800 rpm

M - Higher speed version. ref speed performance data for individual displacements

8 Input Rotation

R – Clockwise (Right hand)
L¹ – Counter-clockwise (Lefthand)

See page 6

9,10 Input Shaft

Standard SAE and ISO splined versions (Other configurations optional)

11 Mounting Flange

Thirteen options in SAE and ISO mounts
See page 6

12 Main Port Location

E² – End Ported
S⁴ – Side Ported

13,14 Main Port Type

SAE & ISO tube ports and 4-bolt flange (Other configurations optional)
See page 7

15,16 Pump Special Features

00 – None
AA – Adjustable Maximum Displacement Stop and single shaft (standard)
AB – Double Shaft Seal, Two Way

17 Control

0 – None
A – Pressure Compensator
B – Pressure and Flow Compensator with Bleed Orifice
C – Pressure and Flow Compensator with Plugged Orifice
E – Industrial/Remote (57cc through 141 cc only)

L - Power Control with Load Sense and Pressure compensator with plugged orifice.

W - Remote pressure control (018-050 size only) with -4 SAE O-ring port, left side

18,19 Pressure Compensator Setting

00 – None
07 – 70 bar (Adjustable between 40 bar and 130 bar)
23 – 230 bar (Adjustable between 130 bar and 320 bar)
28 – 280 bar (Adjustable between 130 bar and 320 bar)

20,21 Flow Compensator Setting

00 – None
10 – Standard for W control
11 – 11 bar setting
20 – 20-20 bar setting
24 – 24-24 bar setting

22,23 Power control Torque Limiter Setting

00 – None
50-50% of rated torque*
(Adjustable from 20-90% of rated torque,*for any other values specify % of rated torque)

24 Compensator Special Features

0 – None

25 Auxiliary Mounting Pad

0³ – None

(Auxiliary mounting available on all frame sizes)
See page 7

26 Paint

0 – No Paint
A – Standard Blue Paint

27 Customer Identification

0 – None (Contact Eaton for Options)

28 Design Code

A – A (Initial Release)

1 Not available on 074, 081, 098 and 106 End Port

2 Not available on 074, 081, 098 and 106 displacement with CCW rotation (“L” in position 8)

3 Through drive not available on the CCW rotation (“L” in position 8) on 074, 081,098 and displacement

4 Not available on 018

Model Code Options

4,5,6 Maximum Geometric Displacement

Displacement Code	018	020	045	050	057	063	074	081	098	106	131	141
cm ³ /r	18,0	21,1	45,1	50,0	57,4	63,1	73,7	81,0	98,3	106,5	131,1	141,0
in ³ /r	1.1	1.29	2.75	3.05	3.50	3.85	4.50	4.94	6.00	6.50	8.00	8.60

9,10 Shaft-End Type at Electric Motor End

Description	Shaft Code					
	PVM018/020	PVM045/050	PVM057/063	PVM074/081	PVM098/106	PVM131/141
SAE, SAE A, Straight Keyed	01	-	-	-	-	-
SAE, SAE 19-1, Straight Keyed	02	-	-	-	-	-
SAE, SAE A, 9T Spline	03	-	-	-	-	-
SAE, SAE A, 11T Spline	04	-	-	-	-	-
SAE, SAE B, Straight Keyed	05	05	-	-	-	-
SAE, SAE B-B, Straight Keyed	06	06	06	-	-	-
SAE, SAE B, 13T Spline	07	07	07	-	-	-
SAE, SAE B-B, 15T Spline	08	08	08	-	-	-
SAE, SAE C, Straight Keyed	-	-	09	09	09	09
SAE, SAE C-C, Straight Keyed	-	-	-	10	10	10
SAE, SAE C, 14T Spline	-	-	11	11	11	11
SAE, SAE C-C, 17T Spline	-	-	-	12	12	12
SAE, SAE D, Straight Keyed	-	-	-	-	-	13
SAE, SAE D, 13T Spline	-	-	-	-	-	14
ISO E20N, Straight Keyed	15	-	-	-	-	-
ISO E25N, Straight Keyed, Short Spigot	16	-	-	-	-	-
ISO E25N, Straight Keyed	17	17	17	-	-	-
ISO E32N, Straight Keyed, Short Spigot	-	-	18	18	18	18
ISO E40N, Straight Keyed, Short Spigot	-	-	-	19	19	19

11 Mounting Flange Specifications

Code	Description	PVM018/020	PVM045/050	PVM057/063	PVM074/081	PVM098/106	PVM131/141
A	SAE A, 2-bolt	●	○	○	○	○	○
B	ISO 80A2HW	●	○	○	○	○	○
C	SAE B, 2-bolt	●	●	●	○	○	○
D	ISO 100A2HW	●	●	●	○	○	○
E	SAE C, 2-bolt	○	○	●	●	●	●
F	ISO 125-A2HW	○	○	●	●	●	●
G	SAE C, 4-bolt	○	○	●	●	●	●
H	ISO 125B4HW	○	○	●	●	●	●
J	SAE D, 4-bolt	○	○	○	○	○	●
K	ISO 160B4HW	○	○	○	○	○	●

● = Available

○ = Not Available

13,14 Main Port Options

Code	Description	Inlet		PVM018/020	PVM045/050	PVM057/063	PVM074/081	PVM098/106	PVM131/141
		Inlet	Outlet						
01	SAE J1926 Tube Ports	Inlet		-20	-24	-24 (End ports only)	-	-	-
		Outlet		-12	-16	-16 (End ports only)	-	-	-
02	SAE J518 Flange Ports	Inlet		1.25 inch	2.0 inch	2.0 inch	2.0 inch	2.5 inch	2.5 inch
		Outlet		0.75 inch	1.0 inch	1.0 inch	1.0 inch	1.0 inch	1.25 inch*
03	ISO 6149-1 Tube Ports	Inlet		M42	M48	M48 (End ports only)	-	-	-
		Outlet		M27	M33	M33 (End ports only)	-	-	-
04	ISO 6162 Flange Ports	Inlet		32mm	51mm	51mm	51mm	64mm	64mm
		Outlet		19mm	25mm	25mm	25mm	25mm	32mm*
05	British Standard Parallel Pipe – Tube Ports	Inlet		G 1-1/4	G 1-1/2	-	-	-	-
		Outlet		G 3/4	G 1	-	-	-	-

*SAE Code 62, high pressure series, or ISO 400 bar. Other flange ports are SAE Code 61, standard pressure series, or ISO 25-350 bar.

25 Thru-Drive Options

Code	Description	PVM018/020	PVM045/050	PVM057/063	PVM074/081*	PVM098/106	PVM131/141
O	Single pump, non-thru-drive	●	●	●	●	●	●
A	SAE A, 2-bolt, 9T spline	●	●	●	●	●	●
B	SAE A, 2-bolt, 11T spline	●	●	○	●	●	●
C	SAE B, 2-1/4-bolt, 13T spline	○	●	●	●	●	●
D	SAE B-B, 2-1/4-bolt, 15T spline	○	●	●	●	●	●
E	SAE C, 2-1/4-bolt, 14T spline	○	○	●	●	●	●
F	SAE C-C, 2-1/4-bolt, 17T spline	○	○	○	●	●	●
G	ISO 80-A2HW, 9T SAE spline	●	●	●	●	●	●
H	ISO 80-A2HW, 11T SAE spline	●	●	○	●	●	●
J	ISO 100-A2/B4HW, 13T SAE spline	○	●	●	●	●	●
K	ISO 100-A2/B4HW, 15T SAE spline	○	○	●	●	●	●
L	ISO 125-A2/B4HW, 14T SAE spline	○	○	●	●	●	●
M	ISO 125-A2/B4HW, 17T SAE spline	○	○	○	●	●	●

● = Available

○ = Not Available

* Not available on the 074/081 LH

Specifications and Performance

Quiet version, optimized for 1000-1800 rpm (E)

Displacement, Pressure and Flow Ratings At 50°C (120°F), SAE 10W oil, 1 bar absolute (0 psig) inlet

Model Series	Maximum Geometric Displacement cm ³ /r (in ³ /r)	Maximum Pressure bar (psi)		Maximum Flow at 280 bar (4000 psi)* l/min (USgpm) – Average measured flow rate			
		Nominal	Peak**	@1800 r/min	@1500 r/min	@1200 r/min	@1000 r/min
PVM018	18 (1.1)	315 (4568)	350 (5000)	31 (8.2)	26 (7)	21 (5.5)	17 (4.5)
PVM020	21,1 (1.29)	230 (3300)	280 (4000)	35 (9)	29 (8)	23 (6)	19 (5)
PVM045	45,1 (2.75)	315 (4568)	350 (5000)	76 (20)	65 (17)	49 (13)	42 (11)
PVM050	50,0 (3.05)	230 (3300)	280 (4000)	87 (23)	75 (20)	62 (16)	49 (13)
PVM057	57,4 (3.50)	315 (4568)	350 (5000)	102 (27)	85 (22.4)	66 (17.4)	54 (14.3)
PVM063	63,1 (3.85)	230 (3300)	280 (4000)	111 (29)	93 (24)	74 (19)	60 (16)
PVM074	73,7 (4.50)	315 (4568)	350 (5000)	127 (33.5)	106 (28)	86 (22.7)	70 (18.5)
PVM081	81,0 (4.94)	230 (3300)	280 (4000)	139 (37)	116 (31)	93 (25)	76 (20)
PVM098	98,3 (6.00)	315 (4568)	350 (5000)	170 (45)	141 (37)	112 (29.6)	92 (24.3)
PVM106	106,5 (6.50)	230 (3300)	280 (4000)	187 (49)	155 (41)	123 (32)	102 (27)
PVM131	131,1 (8.00)	315 (4568)	350 (5000)	215 (57)	178 (47)	141 (37)	118 (31)
PVM141	141,0 (8.60)	230 (3300)	280 (4000)	238 (63)	199 (53)	158 (42)	131 (35)

**Momentary system pressure spikes only.

Speed, Input Power and Torque Ratings At 50°C (120°F), SAE 10W oil, 1 bar absolute (0 psig) inlet

Model Series	Maximum Operating Speed r/min	Maximum Input Power at 280 bar (4000 psi) kw (hp)*@88% M.E.				Maximum Torque at 280 bar (4000 psi)* Nm (lb-ft)	Approximate Weight kg (lb)
		@1800 r/min	@1500 r/min	@1200 r/min	@1000 r/min		
PVM018	1800	16 (22)	13 (18)	11 (15)	9 (12)	84 (62)	15 (33)
PVM020	1800	14 (18)	11 (15)	9 (12)	8 (10)	73 (54)	15 (33)
PVM045	1800	41 (55)	34 (46)	27 (37)	23 (31)	221 (163)	24 (52)
PVM050	1800	35 (47)	30 (40)	28 (38)	23 (31)	190 (140)	24 (52)
PVM057	1800	52 (70)	44 (59)	36 (49)	29 (39)	272 (201)	36 (79)
PVM063	1800	42 (57)	36 (48)	29 (39)	24 (32)	228 (168)	36 (79)
PVM074	1800	63 (84)	52 (70)	42 (56)	35 (47)	334 (246)	45 (99)
PVM081	1800	56 (75)	46 (62)	35 (47)	28 (37)	286 (211)	45 (99)
PVM098	1800	88 (118)	72 (97)	58 (78)	48 (64)	464 (342)	55 (121)
PVM106	1800	72 (97)	60 (80)	48 (64)	40 (54)	383 (282)	55 (121)
PVM131	1800	113 (152)	94 (126)	75 (101)	63 (85)	596 (440)	66 (145)
PVM141	1800	94 (126)	79 (106)	63 (85)	53 (71)	497 (367)	66 (145)

Standard Response Times*

Model Series	On Stroke (msec)	Off Stroke (msec)
PVM018	30	25
PVM020	39	26
PVM045	140	40
PVM050	140	40
PVM057	65	20
PVM063	85	20

* 3300 psi on overbore pumps

Standard Response Times*

Model Series	On Stroke (msec)	Off Stroke (msec)
PVM074	85	30
PVM081	85	30
PVM098	65	25
PVM106	72	29
PVM131	135	30
PVM141	100	30

*Values with pressure compensator control.

Specifications and Performance

Higher speed version (M)

Displacement, Pressure and Flow Ratings At 93°C (200°F), SAE 10W oil, 1 bar absolute (0 psig) inlet

Model Series	Geometric Displacement cm ³ /r (in ³ /r)	Maximum Pressure bar (psi)		Maximum Flow at 280 bar (4000 psi)	
		Nominal	Peak**	Flange Ports l/min (USgpm) @ 1 bar inlet	Tube Ports l/min (USgpm) @ 1 bar inlet
PVM018	18,0 (1.10)	315 (4568)	350 (5000)	46 (12) @ 2800 r/min	46 (12) @ 2800 r/min
PVM020	20,1 (1.22)	230 (3300)	280 (4000)	53 (14) @ 2800 r/min	53 (14) @ 2800 r/min
PVM045	45,1 (2.75)	315 (4568)	350 (5000)	115 (30) @ 2600 r/min	106 (28) @ 2400 r/min
PVM050	50,0 (3.05)	230 (3300)	280 (4000)	125 (33) @ 2600 r/min	116 (31) @ 2400 r/min
PVM057	57,4 (3.50)	315 (4568)	350 (5000)	140 (37) @ 2500 r/min	128 (34) @ 2300 r/min
PVM063	63,1 (3.85)	230 (3300)	280 (4000)	150 (40) @ 2500 r/min	140 (37) @ 2400 r/min
PVM074	73,7 (4.50)	315 (4568)	350 (5000)	163 (43) @ 2400 r/min	–
PVM081	81,0 (4.94)	230 (3300)	280 (4000)	181 (48) @ 2400 r/min	–
PVM098	98,3 (6.00)	315 (4568)	350 (5000)	200 (53) @ 2200 r/min	–
PVM106	106,5 (6.50)	230 (3300)	280 (4000)	222 (59) @ 2200 r/min	–
PVM131	131,1 (8.00)	315 (4568)	350 (5000)	233 (62) @ 2000 r/min	–
PVM141	141,0 (8.60)	230 (3300)	280 (4000)	258 (68) @ 2000 r/min	–

**Less than 0.5 second.

Standard Response Times*

Model Series	On Stroke (msec)	Off Stroke (msec)
PVM018	50	20
PVM020	57	22
PVM045	140	40
PVM050	140	23
PVM057	65	20
PVM063	94	20

Standard Response Times*

Model Series	On Stroke (msec)	Off Stroke (msec)
PVM074	95	30
PVM081	135	30
PVM098	85	24
PVM106	90	25
PVM131	100	30
PVM141	128	28

*Values with pressure compensator control.

Specifications and Performance

Higher speed version (M)

Speed, Input Power and Torque Ratings At 93°C (200°F), SAE 10W oil, 1 bar absolute (0 psig) inlet

Approximate Model Series	Operating Speed and Pressure r/min			Max. Input Power at	Max. Torque at	
	1 bar Inlet Flange Ports	Tube Ports	0,85 bar Inlet Flange Ports	Max. Speed and 280 bar (4000 psi) kW (hp)	280 bar (4000 psi) Nm (lb-ft)	Weight (dry) kg (lbs)
PVM018	2800 r/min			24 (32)		
		2800 r/min		24 (32)	82 (60)	15 (33)
			2600 r/min	22 (30)		
PVM020	2800 r/min			21 (28)		
		2800 r/min		21 (28)	72 (53)	15 (33)
			2600 r/min	20 (27)		
PVM045	2600 r/min			56 (75)		
		2400 r/min		53 (71)	198 (46)	24 (52)
			2200 r/min	48 (64)		
PVM050	2600 r/min			51 (68)		
		2400 r/min		48 (64)	204 (150)	24 (52)
			2200 r/min	44 (59)		
PVM057	2500 r/min			68 (91)		
		2300 r/min		62 (83)	262 (193)	36 (79)
			2100 r/min	56 (75)		
PVM063	2500 r/min			59 (79)		
		2400 r/min		57 (76)	225 (166)	36 (79)
			2200 r/min	52 (69)		
PVM074	2400 r/min			84 (113)		
			1900 r/min	69 (93)	334 (246)	45 (99)
PVM081	2400 r/min			69 (93)		
			1900 r/min	55 (74)	276 (204)	45 (99)
PVM098	2200 r/min			105 (141)		
			1800 r/min	86 (115)	457 (337)	55 (121)
PVM106	2200 r/min			87 (117)		
			1800 r/min	70 (94)	377 (278)	55 (121)
PVM131	2000 r/min			122 (164)		
			1600 r/min	98 (131)	581 (429)	66 (145)
PVM141	2000 r/min			102 (137)		
			1600 r/min	81 (109)	483 (356)	66 (145)

Specifications and Performance

Variable Speed Drive

Variable Speed Performance- System Pressure vs Speed

Model Series	Max Speed "E"* (rpm)	Max Speed "M"*(rpm)	Min Speed (rpm)	Nominal Pressure (bar)	Peak Pressure (bar)**	Inertia (kg-cm2)
PVM018	1800	2800	0	315	350	11.8
PVM020	1800	2800	0	230	280	11.8
PVM045	1800	2600	0	315	350	36.2
PVM050	1800	2600	0	230	280	33.9
PVM057	1800	2500	0	315	350	51.6
PVM063	1800	2500	0	230	280	50.5
PVM074	1800	2400	0	315	350	78.1
PVM081	1800	2400	0	230	280	72.7
PVM098	1800	2200	0	315	350	131.6
PVM106	1800	2200	0	230	280	122.7
PVM131	1800	2000	0	315	350	213.5
PVM141	1800	2000	0	230	280	209.7

* Valve plate type

**Less than 0.5 second.

PVM System Pressure vs. Shaft Speed

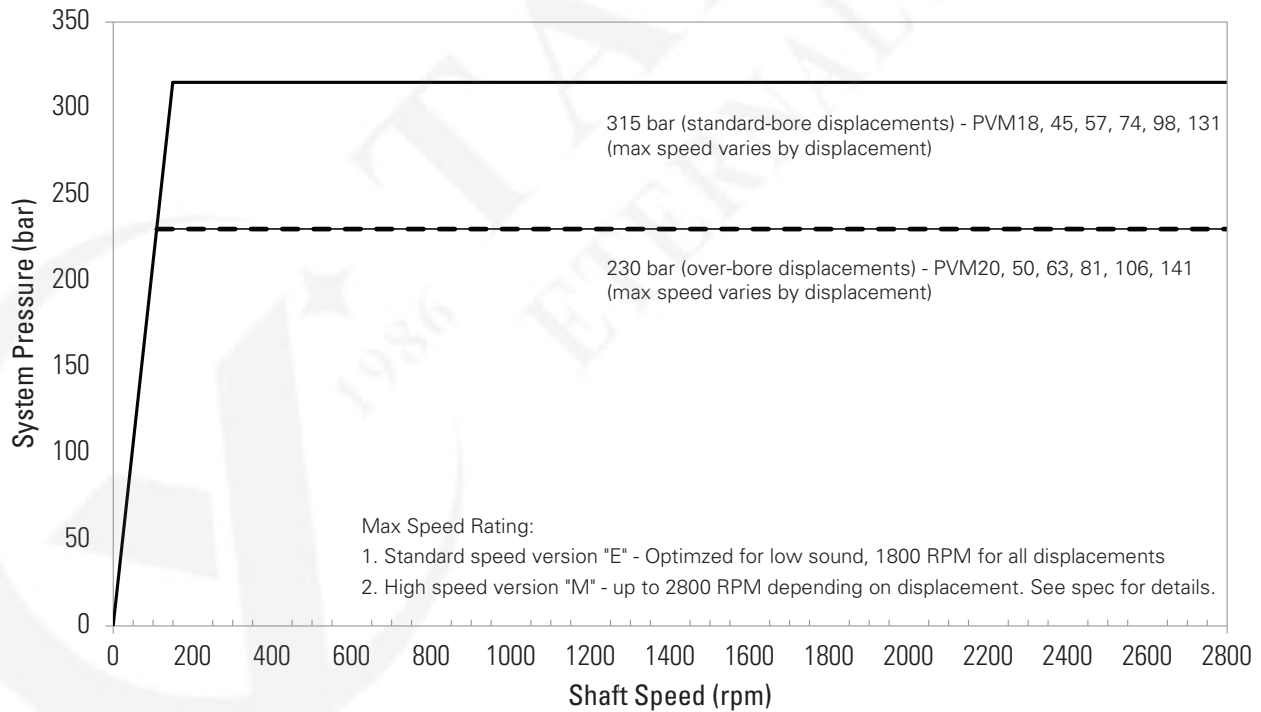

Test condition: Mineral oil SAE 10W, oil temperature 49° C (120° F), 1 bar absolute inlet pressure.

End-ported Models

PVM018/020

Dimensions in millimeters (inches)

Drain port "F" (See options on page 107.)

See shaft options starting on page 102.

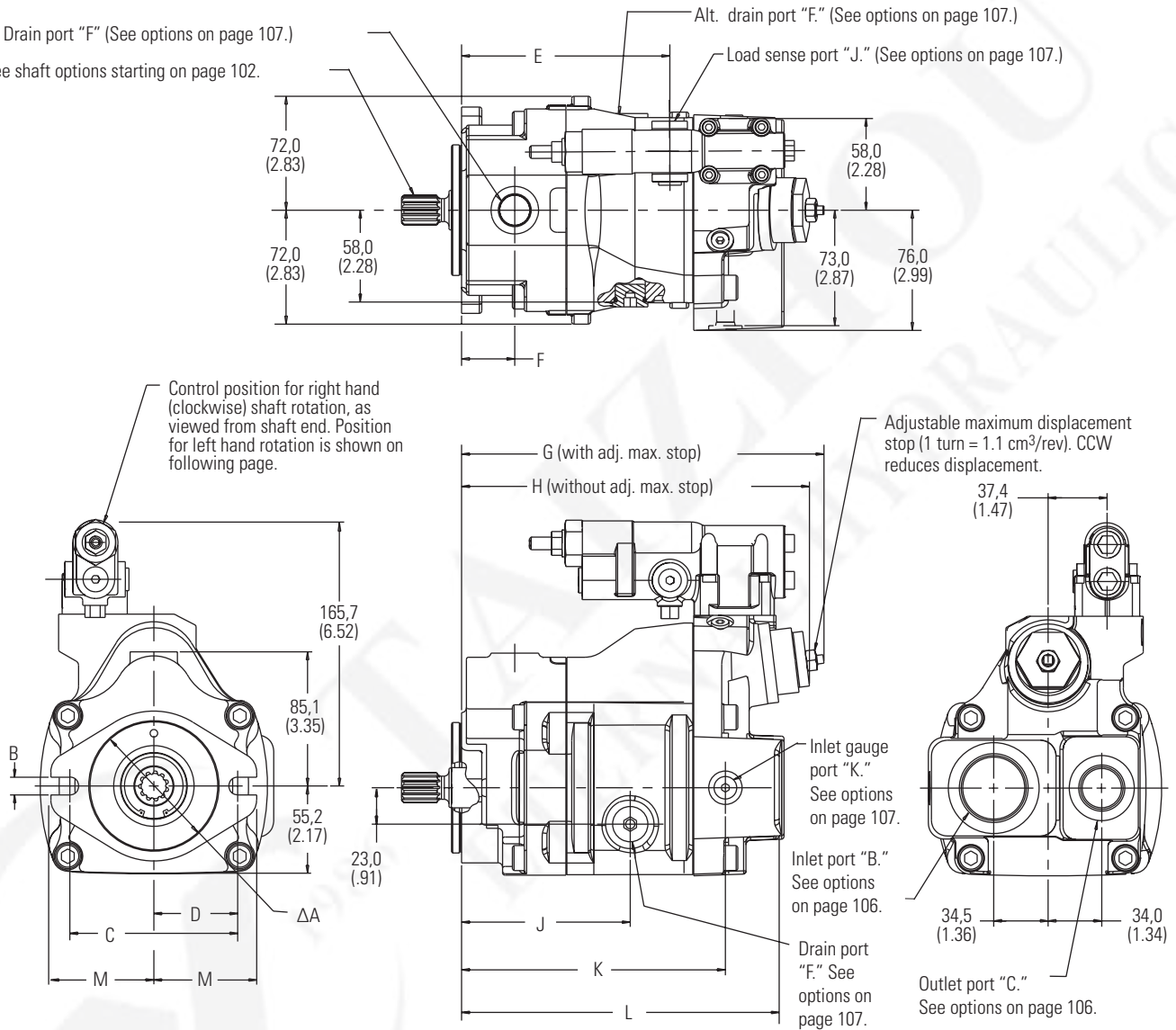

Dimensions in millimeters (inches)

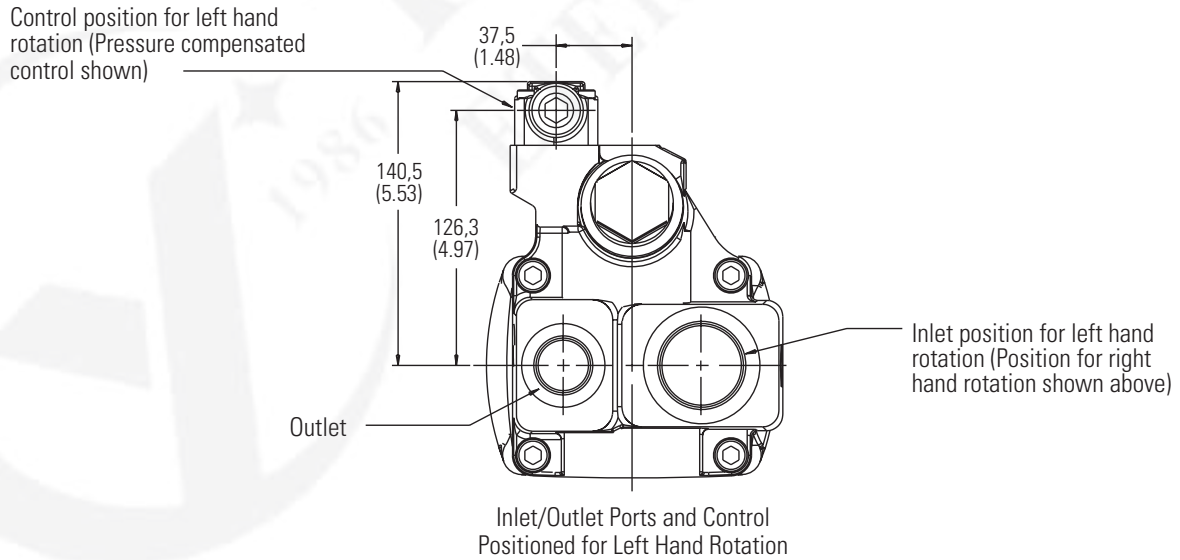
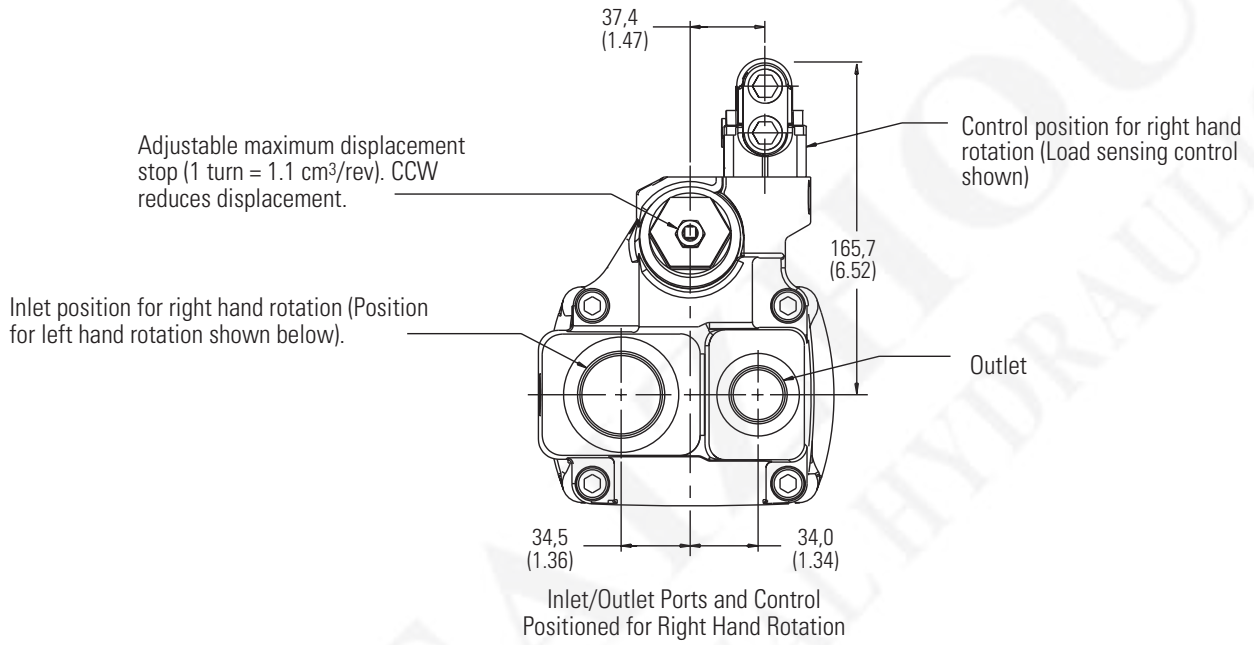

Side-ported Models

PVM018/020

Dimensions in millimeters (inches)

Load sense port "J"

(See options on page 107)

Alt. drain port "F"

(See options on page 107)

Drain port "E"

(See options on page 107)

See shaft options starting
on page 102.

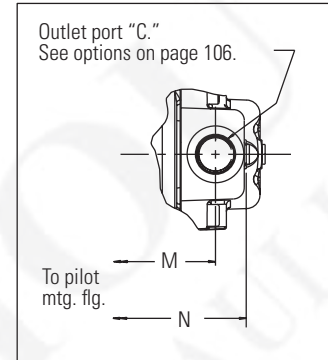
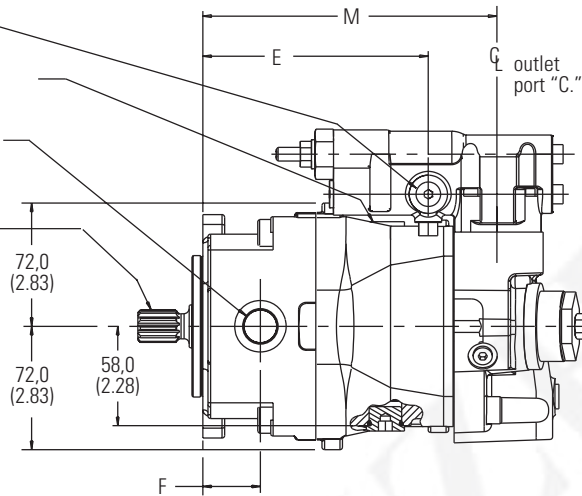

Outlet port "C."
See options on page 106.

To pilot
mtg. fig.

Adjustable maximum displacement
stop (1 turn = 1.1 cm³/rev). CCW
reduces displacement.

Outlet port "C" (above).
See options on page 106.

Inlet port "B."
See options on page 106.

Control position for right hand
(clockwise) shaft rotation, as viewed
from shaft end. Position for left hand
rotation is shown on following page.

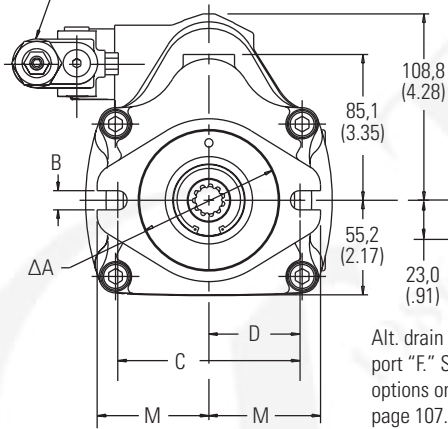

Dimensions in millimeters (inches)

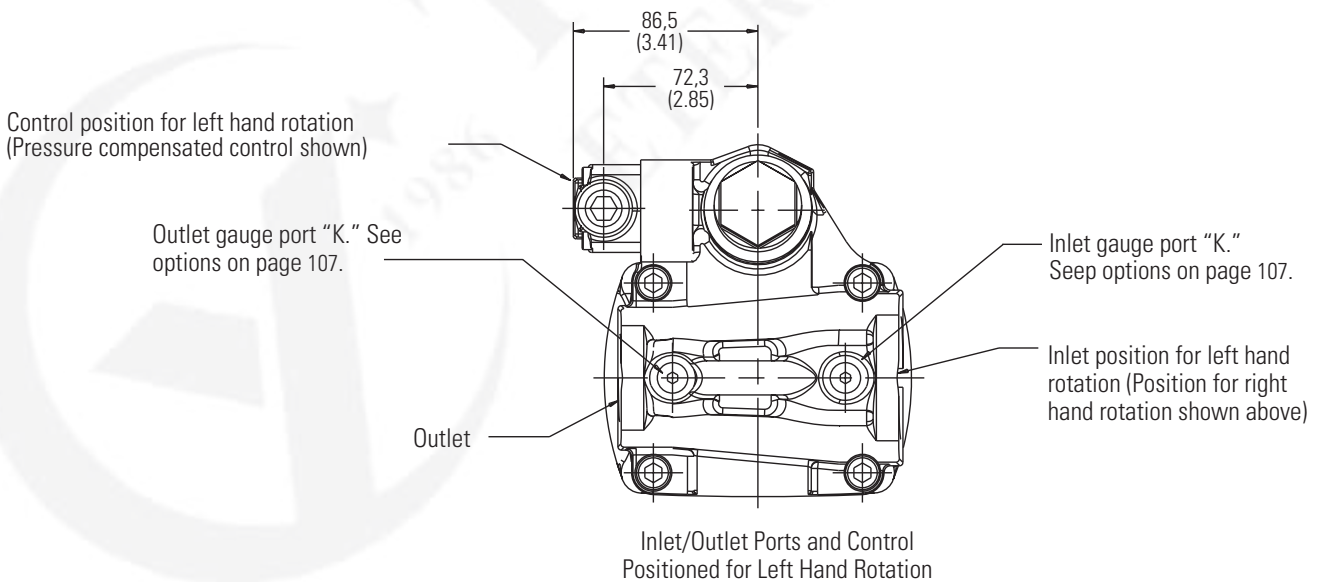
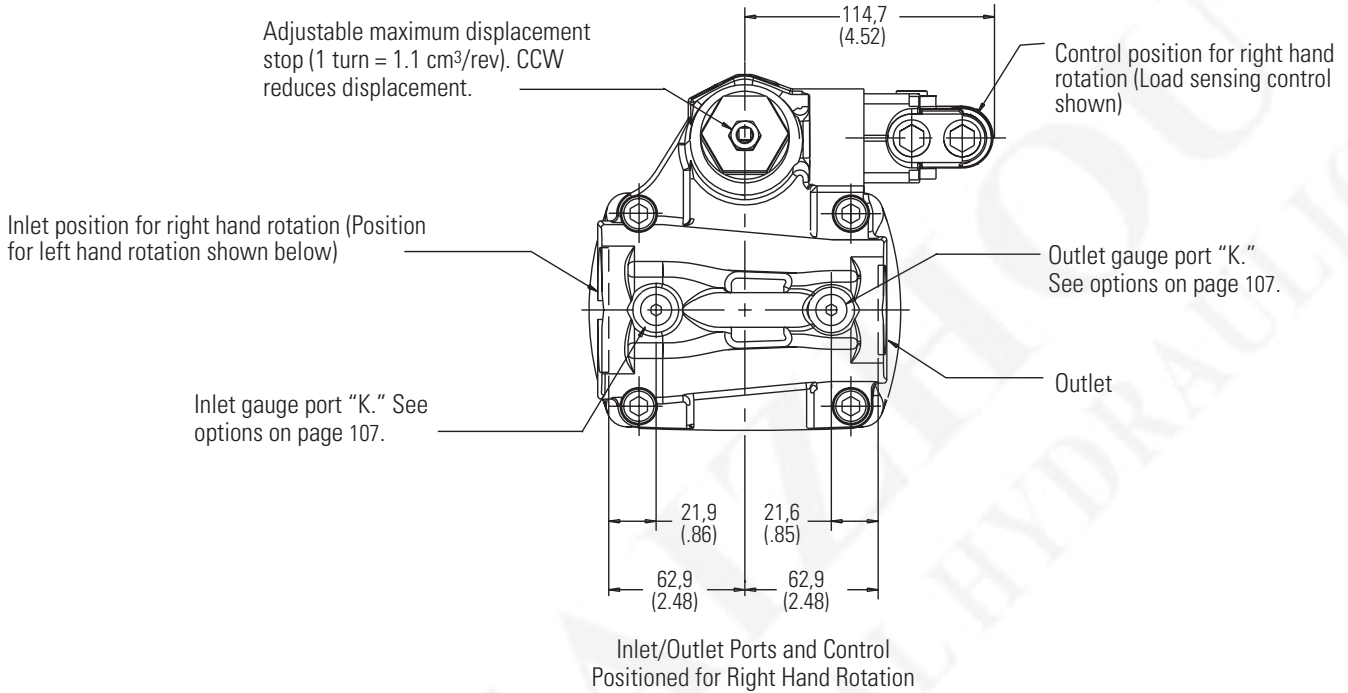

Thru-drive Models

PVM018/020

Dimensions in millimeters (inches)

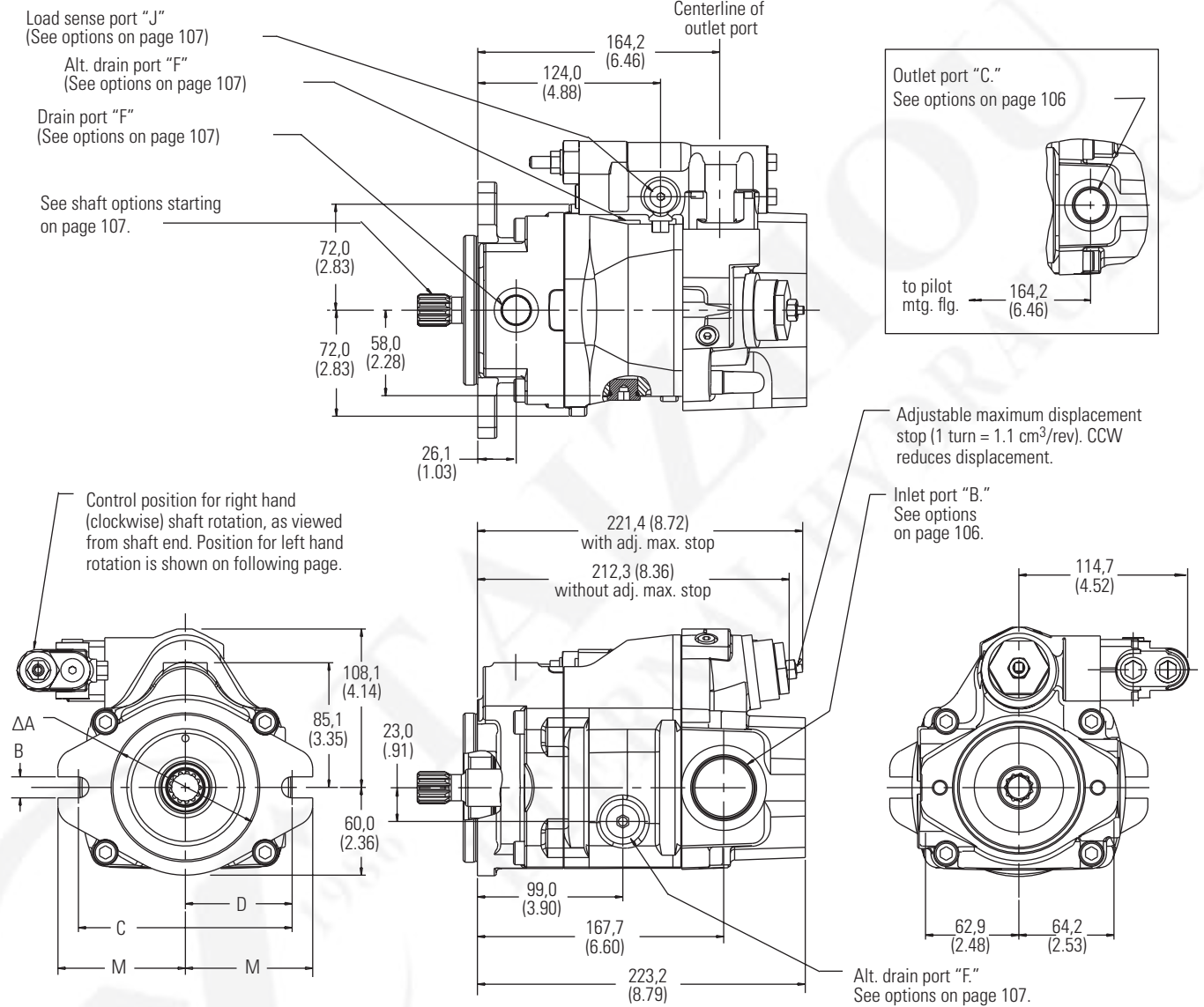

Model Code Position 25

Description

A	For SAE "A" pad with a 9T, 16/32 DP, 30° pressure angle, involute spline
B	For SAE "A" pad with a 11T, 16/32 DP, 30° pressure angle, involute spline
G	For ISO 80 A2HW pad with a 9T SAE spline
H	For ISO 80 A2HW pad with a 11T SAE spline

Dimensions in millimeters (inches)

Adjustable maximum displacement stop (1 turn = 1.1 cm³/rev). CCW reduces displacement.

Inlet position for right hand rotation (Position for left hand rotation shown below)

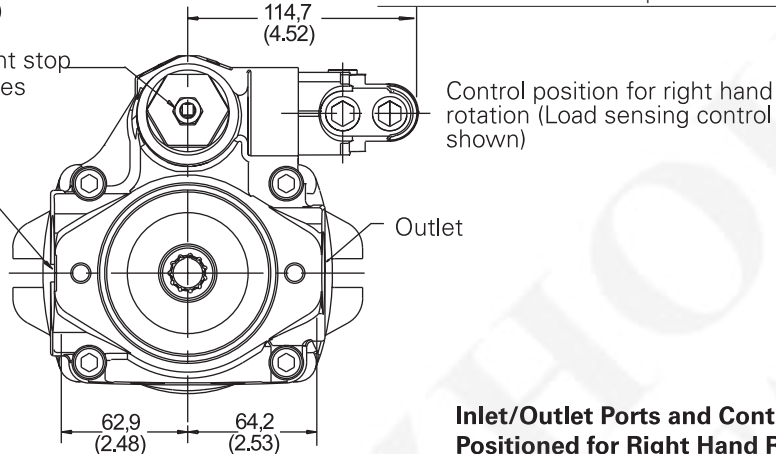

Inlet/Outlet Ports and Control Positioned for Right Hand Rotation

Control position for left hand rotation (Pressure compensator control shown)

Output shaft 21T, 32/64 DP, 30° PA involute spline.

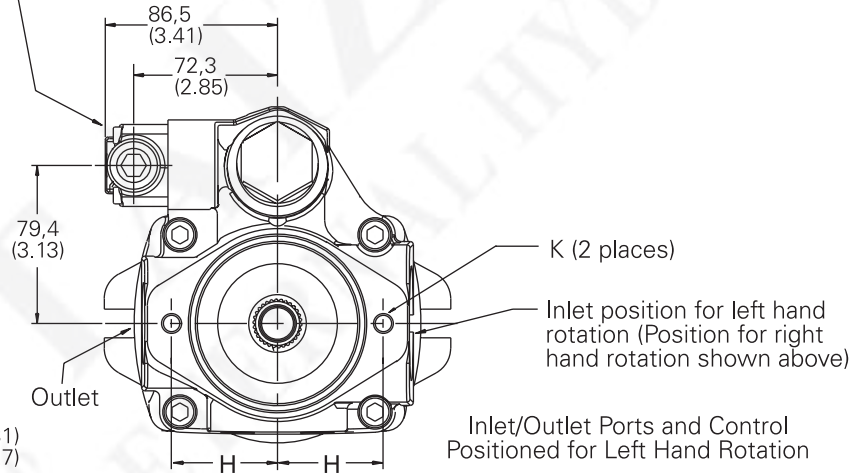
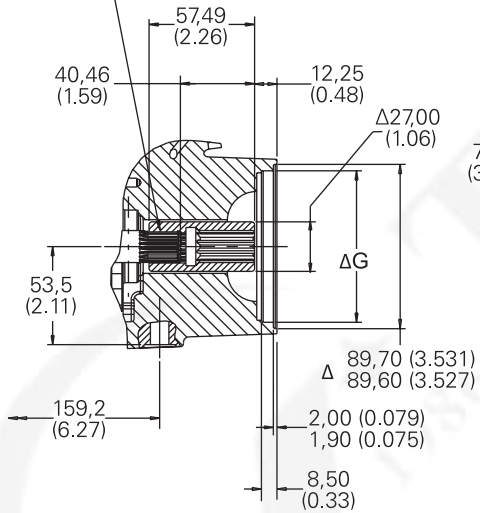

Inlet/Outlet Ports and Control Positioned for Left Hand Rotation

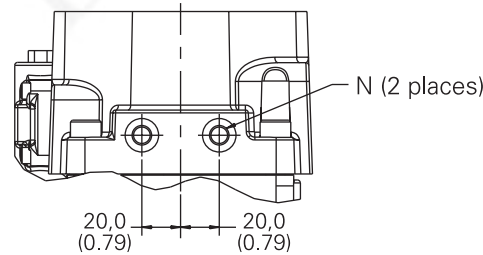

Model Code Position 25	ØG	H	K	N
A,B	82,625 (3.253) 82,575 (3.251)	53,2 (2.09)	375-16 UNC-2B thd. 0.75 deep min	375-16 UNC-2B thd. 0.62 deep min.
G,H	80,046 (3.151) 80,002 (3.150)	54,5 (2.15)	M10 x 1,50 thd. 19,05 deep min	M10 x 1,50 thd. 15,88 deep min.

Flange Designations

PVM018/020

"A" Pilot Flange Designation	ØA	B	C	D	E	F	G	H	J	K	L	M
SAE J744-82-2 Model Code A	82,55 (3.25)	11,35/10,97 (.447/.432)	106,4 (4.19)	53,2 (2.09)	131,5 (5.18)	33,6 (1.32)	228,9 (9.00)	219,8 (8.65)	106,5 (4.19)	166,7 (6.56)	200,7 (7.90)	65,2 (2.57)
ISO 3019/2-80A2HW Model Code B	80,00 (3.15)	11,27/11,00 (.444/.433)	109,0 (4.29)	54,5 (2.15)								

"B" Pilot Flange Designation	ØA	B	C	D	E	F	G	H	J	K	L	M
SAE J744-101-2 Model Code C	101,60 (4.00)	14,55/14,17 (.572/.557)	146,0 (5.750)	73,0 (2.875)	124,0 (4.88)	26,1 (1.03)	221,4 (8.72)	212,3 (8.36)	99,0 (3.90)	159,2 (6.27)	193,9 (7.63)	87,0 (3.43)
ISO 3019/2-100A2HW Model Code D	100,00 (3.937)	14,27/14,00 (.562/.551)	140,0 (5.512)	70,0 (2.756)								

Pilot Flange Designation	ØA	B	C	D
SAE J744-127-2 Model Code C	101,60 (4.00)	14,55/14,17 (.572/.558)	146,0 (5.75)	73,0 (2.87)
ISO 3019/2-100 A2HW Model Code D	100,00 (3.94)	14,27/14,00 (.562/.551)	140,0 (5.51)	70,0 (2.76)

End-ported Models

PVM045/050

Dimensions in millimeters (inches)

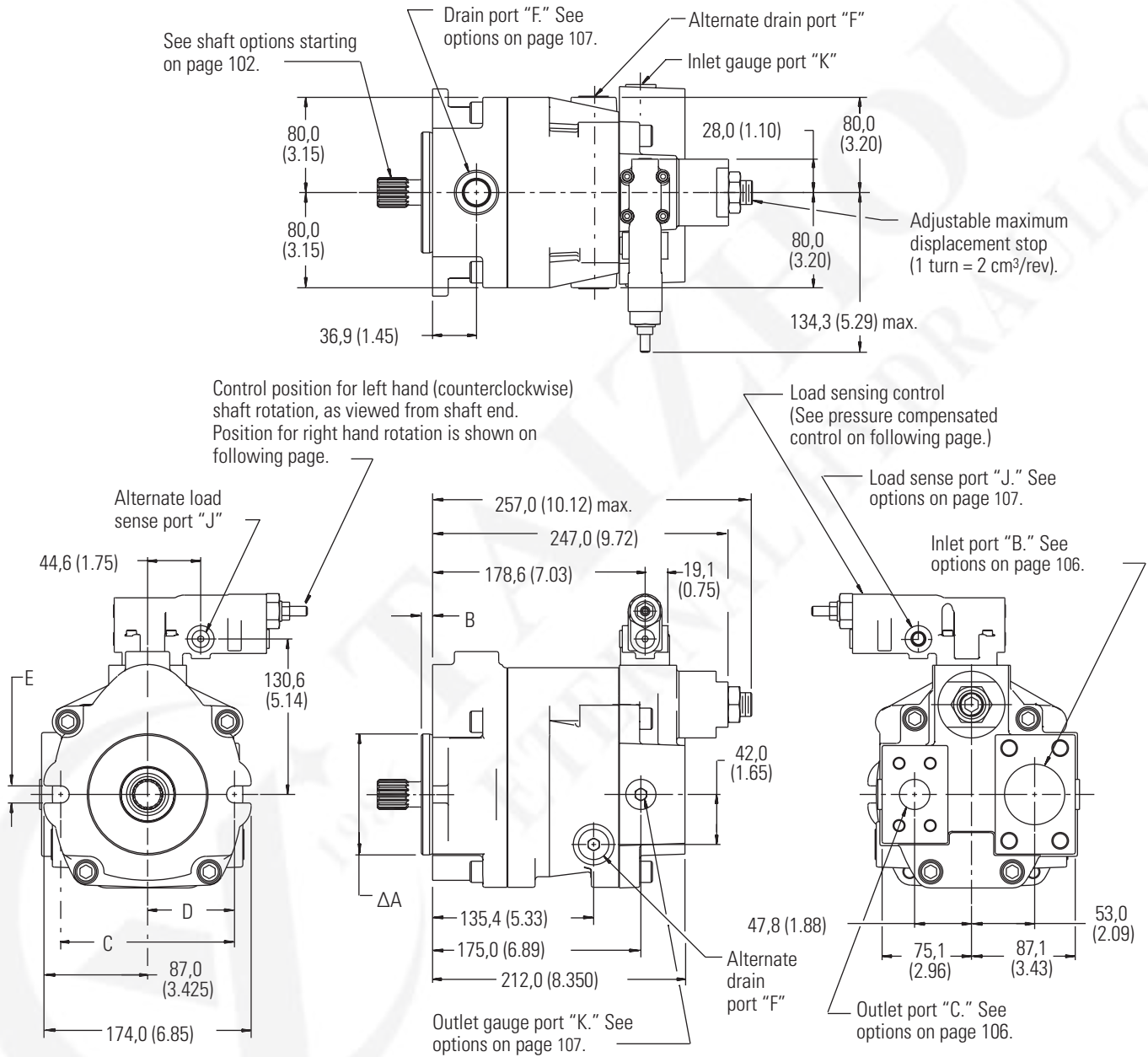

Dimensions in millimeters (inches)

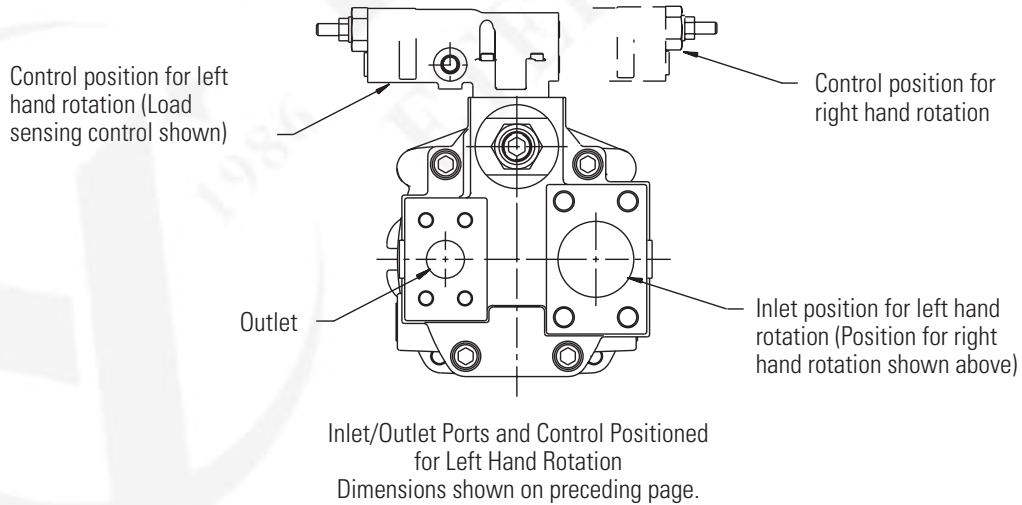
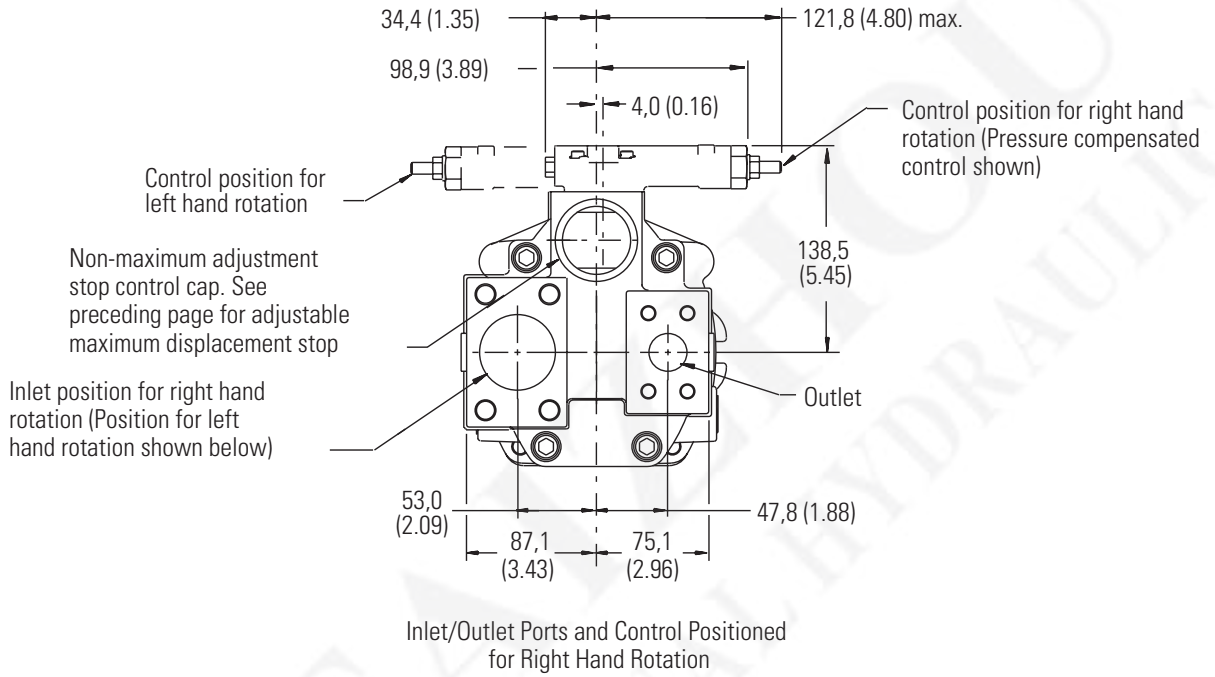

Side-ported Models

PVM045/050

Dimensions in millimeters (inches)

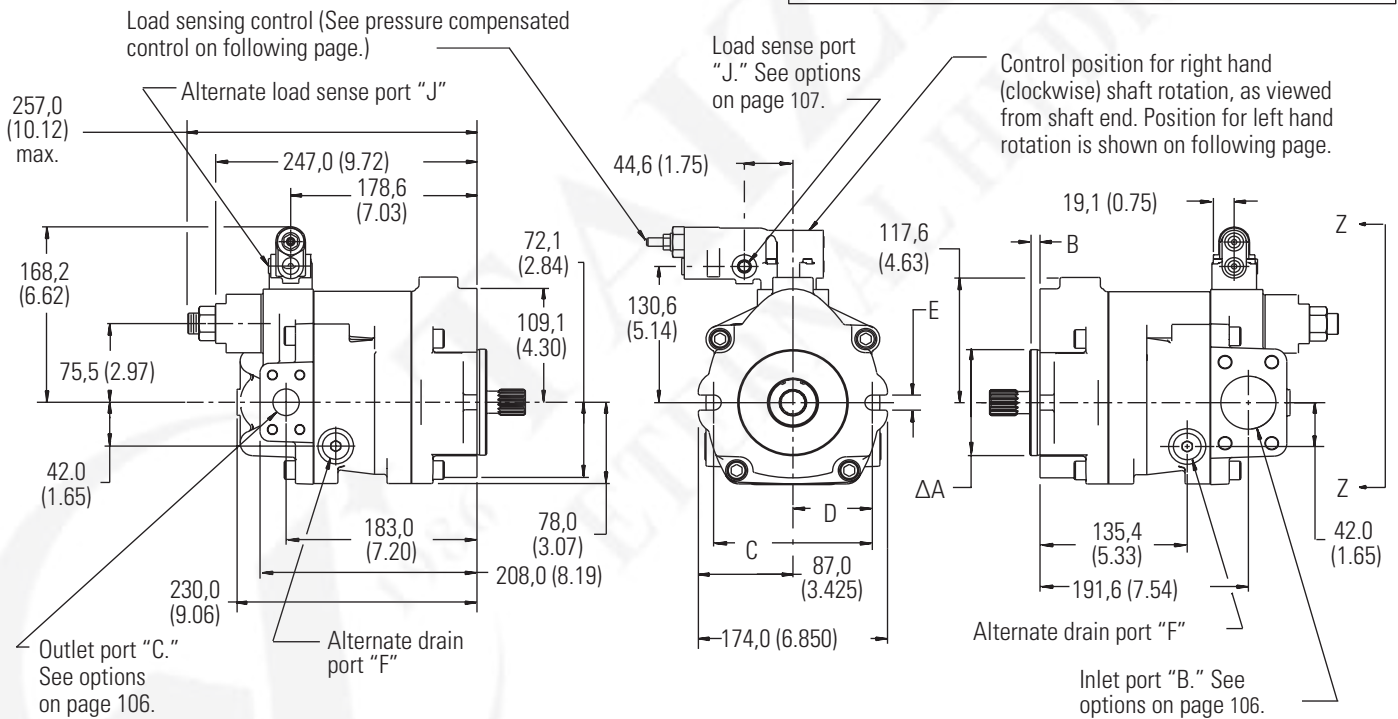
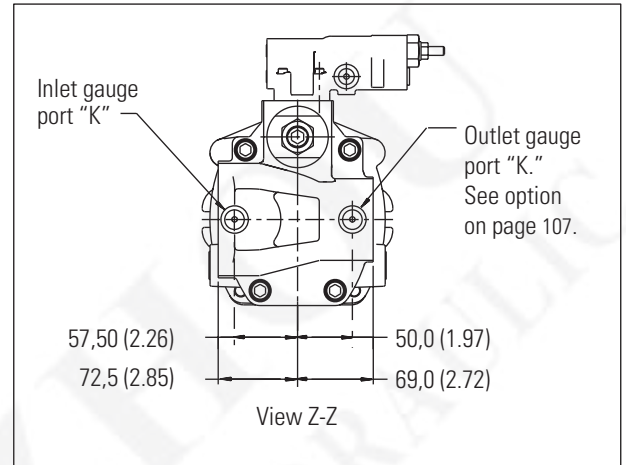
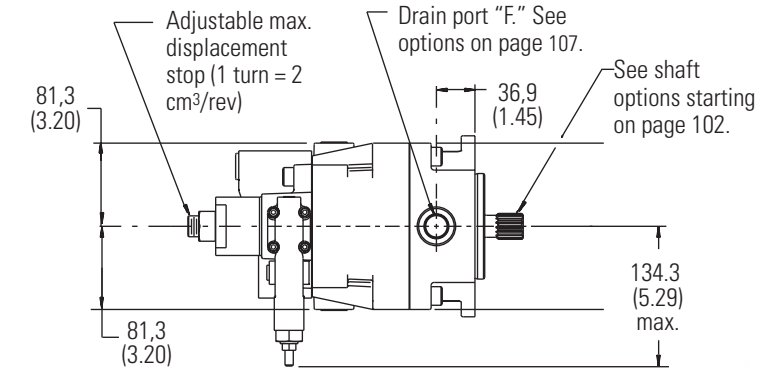

Dimensions in millimeters (inches)

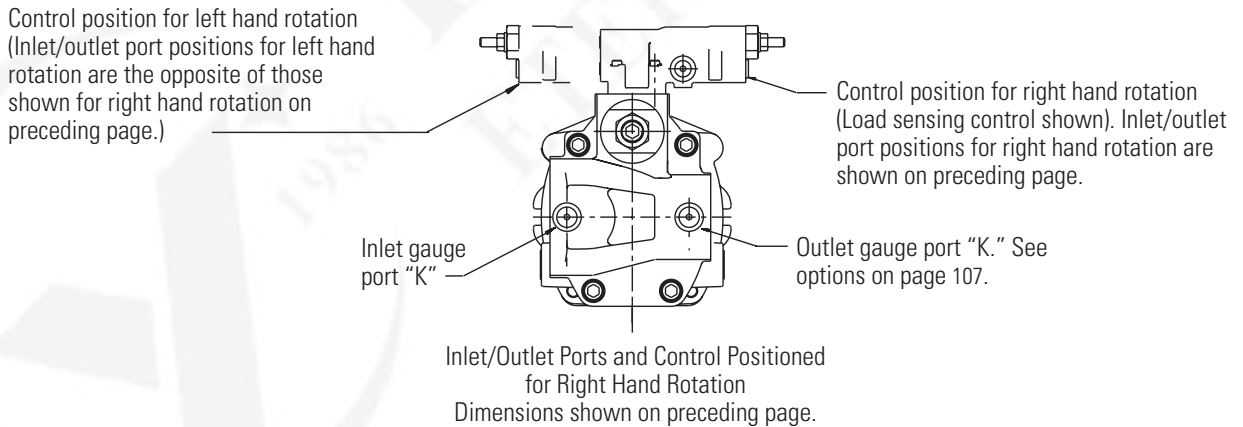
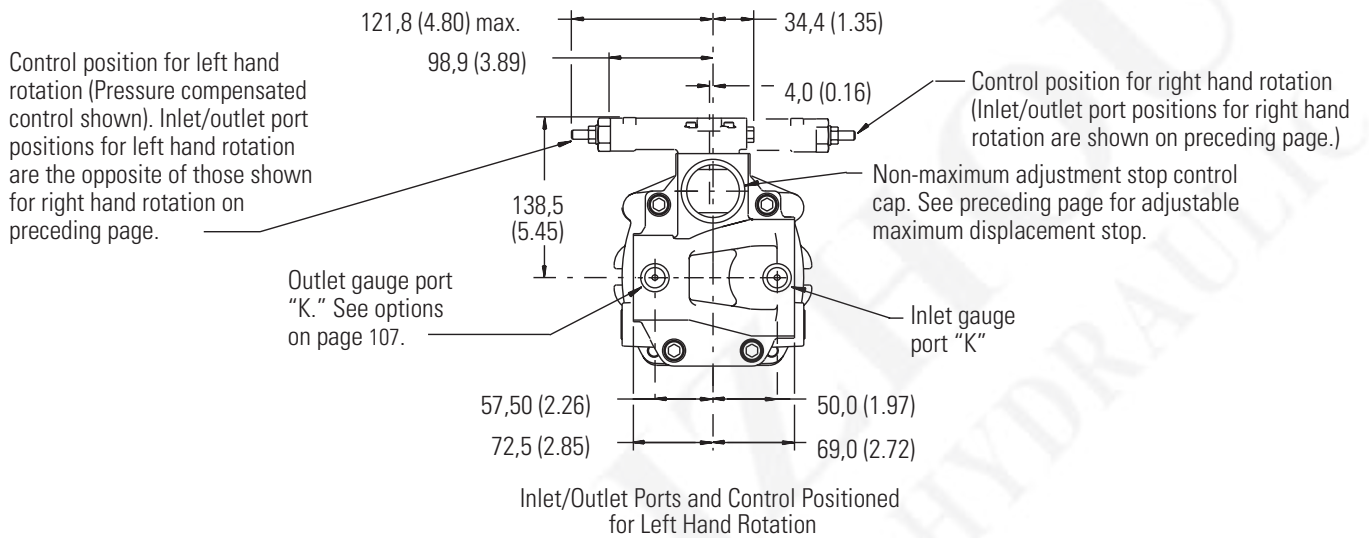

Thru-drive Models

PVM045/050

Dimensions in millimeters (inches)

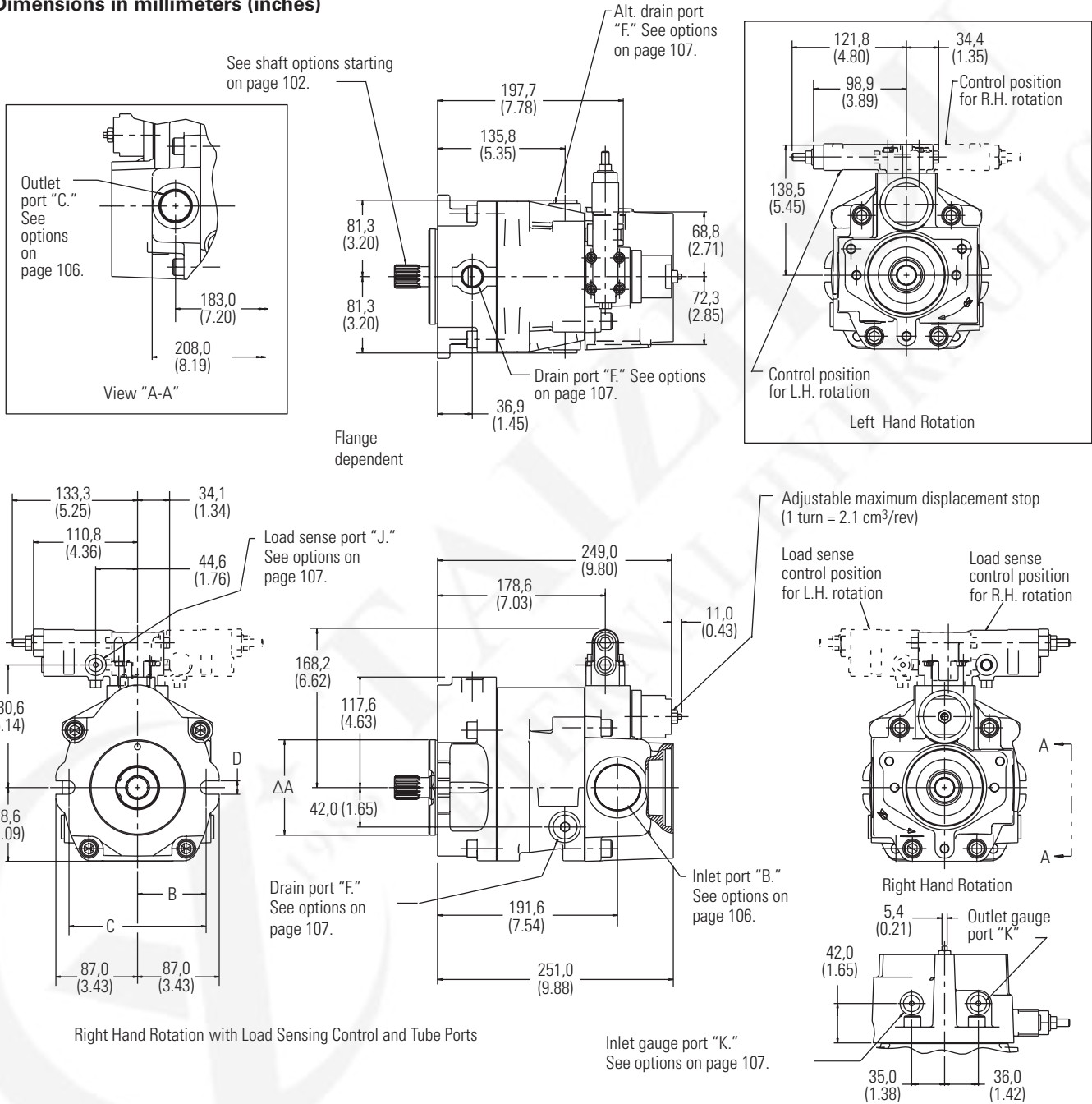

Dimensions in millimeters (inches)

"A" Pad

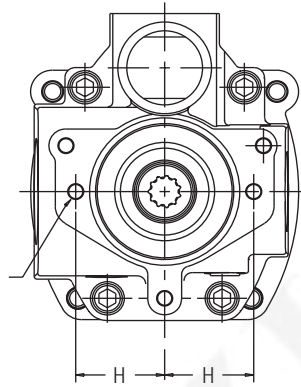
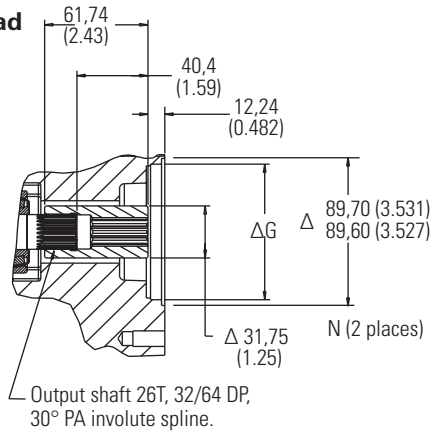

"B" Pad

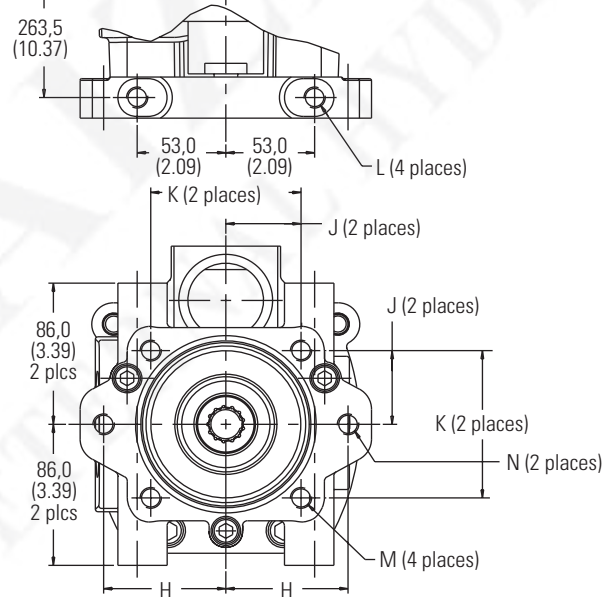
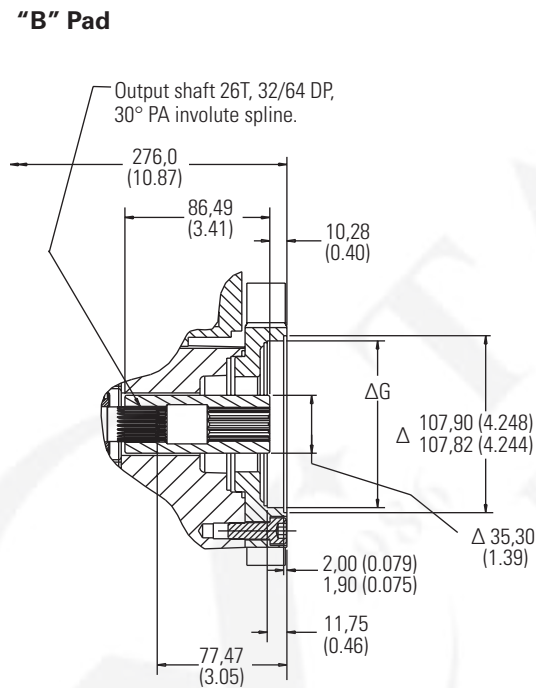

Model Code Position 25

Description

Position	Description
A	For SAE "A" pad with a 9T, 16/32 DP, 30° pressure angle, involute spline
B	For SAE "A" pad with a 11T, 16/32 DP, 30° pressure angle, involute spline
C	For SAE "B" pad with a 13T, 16/32 DP, 30° pressure angle, involute spline
D	For SAE "B" pad with a 15T, 16/32 DP, 30° pressure angle, involute spline
G	For ISO 80-A2HW pad with a 9T SAE spline
H	For ISO 80-A2HW pad with a 11T SAE spline
J	For ISO 100-A2/B4HW pad with a 13T SAE spline

Model Code Position 25	ØG	H	J	K	L	M	N
A,B	82,58 (3.251) 82,52 (3.249)	53,2 (2.09)	-	-	-	-	.375-16 UNC-2B thd. 0.60 deep min.
G,H	80,046 (3.15) 80,002 (3.149)	54,5 (2.15)	-	-	-	-	M10 thd. x 1,50 15,0 deep min.
C,D	101,65 (4.002) 101,60 (4.00)	73,0 (2.87)	44,9 (1.77)	89,8 (3.54)	.500-13 UNC-2B thd. 24,9 deep min. M12 x 1,50 thd. 24,9 deep min.	.500-13 UNC-2B thd. thru M10 x 1,50 thd. thru	.500-13 UNC-2B thd. thru M12 x 1,50 thd. thru
J,K	100,0 (3.937) 99,946 (3.935)	70,0 (2.76)	44,2 (1.74)	88,38 (3.48)	M12 thd. x 1,50 thd. 24,9 deep min.	M10 x 1,50 thd. thru	M12 x 1,50 thd. thru

Flange Designations

PVM045/050

Pilot Flange Designation	ØA	B	C	D	E
SAE J744-101-2	101,60/101,55 (4.000/3.998)	9,70/9,19 (.382/.362)	146,0 (5.750)	73,0 (2.875)	14,55/14,17 (.572/.557)
ISO 3019/2-100A2HW	100,00/99,95 (3.937/3.935)	9,50/9,00 (.374/.354)	140,0 (5.512)	70,0 (2.756)	14,27/14,00 (.562/.551)

Pilot Flange Designation	ØA	B	C	D
SAE 2-bolt mount	101,60/101,55 (4.000/3.998)	73,0 (2.87)	146,0 (5.750)	14,55/14,17 (.572/.557)
ISO 100 2-bolt mount	100,00/99,95 (3.937/3.935)	70,0 (2.76)	140,0 (5.512)	14,27/14,00 (.562/.551)

End-ported Models

PVM057/063

Dimensions in millimeters (inches)

See mounting flange options on page 101.

See shaft options starting on page 102.

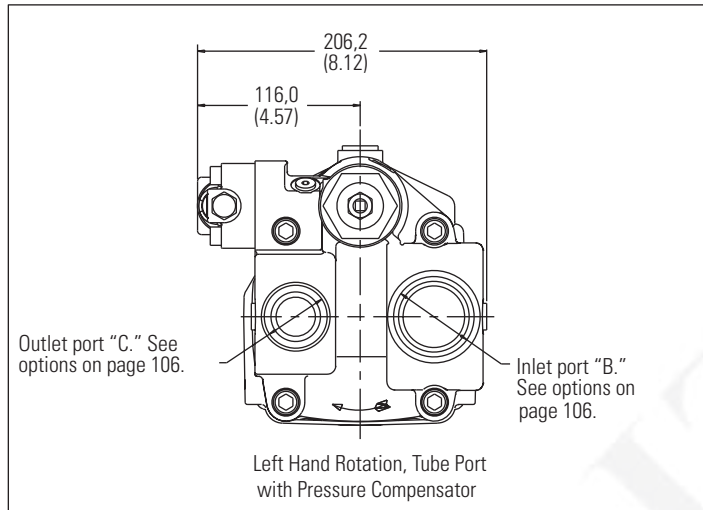

SAE .500-13
UNC-2B thd. 1.06
deep min.
ISO M12 x 1,75 thd.
29.0 deep min.

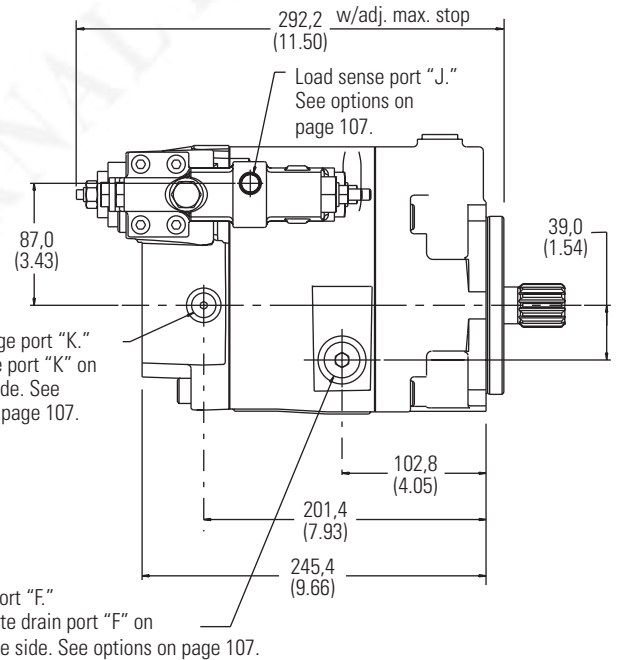
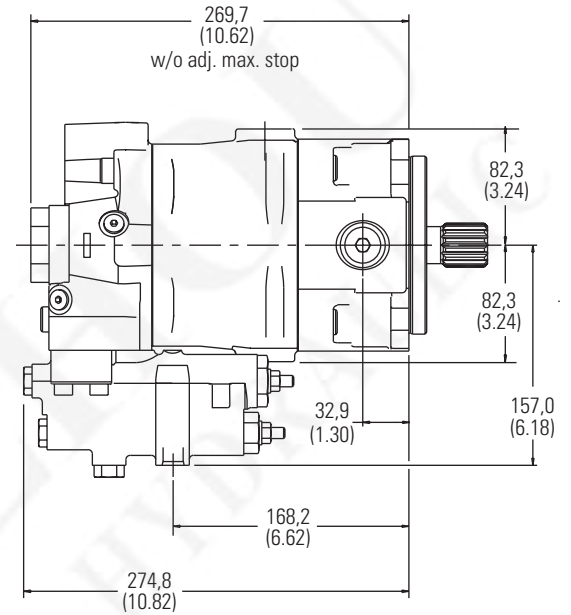
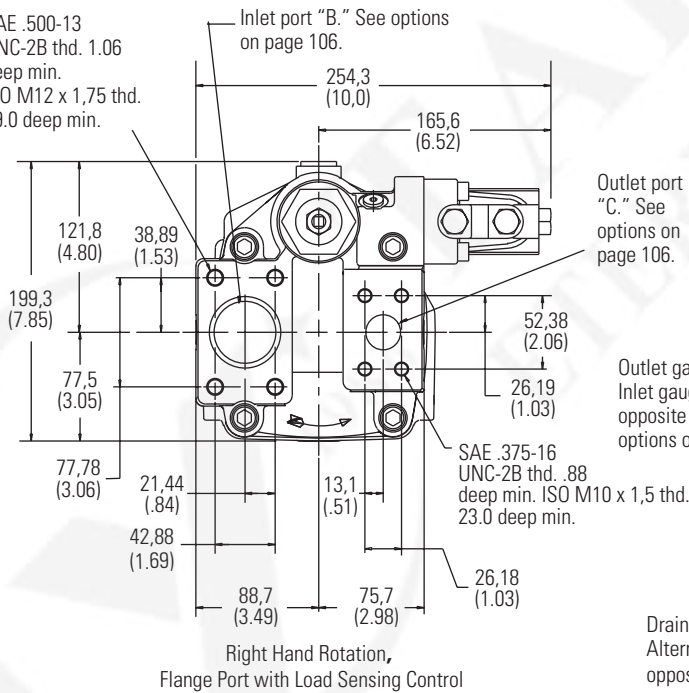

Side-ported Models

PVM057/063

Dimensions in millimeters (inches)

See mounting flange options on page 101.

See shaft options starting on page 102.

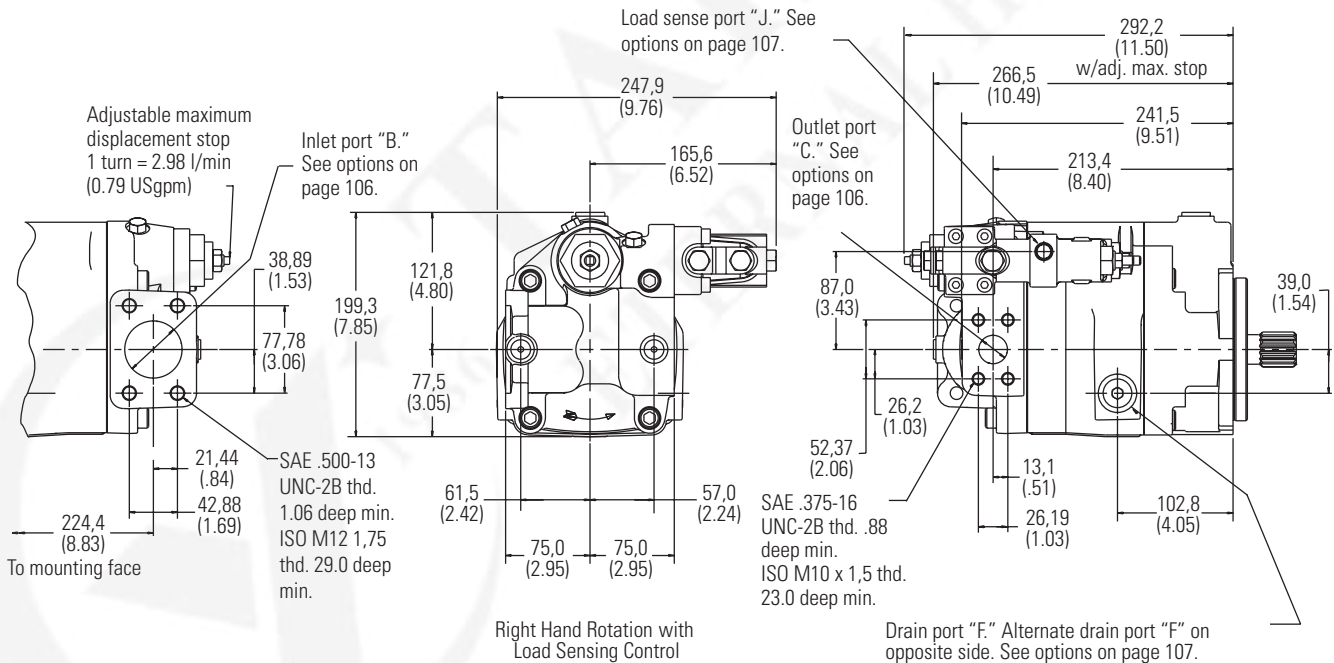
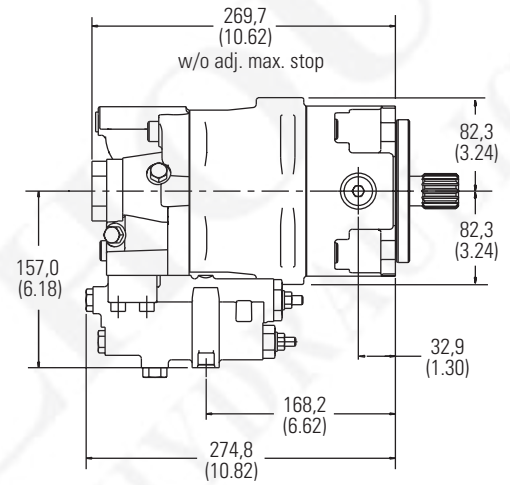
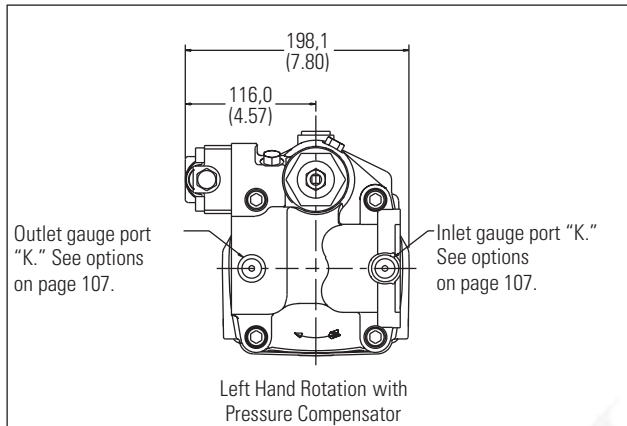

Thru-drive Models

PVM057/063

Dimensions in millimeters (inches)
See pilot flange options on page 101.
See shaft options starting on page 102.

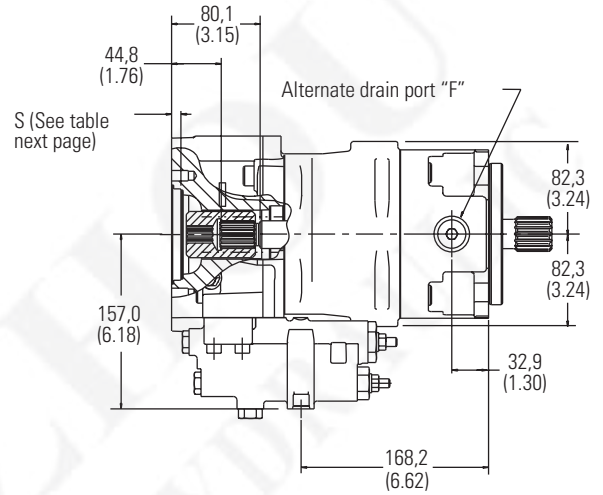
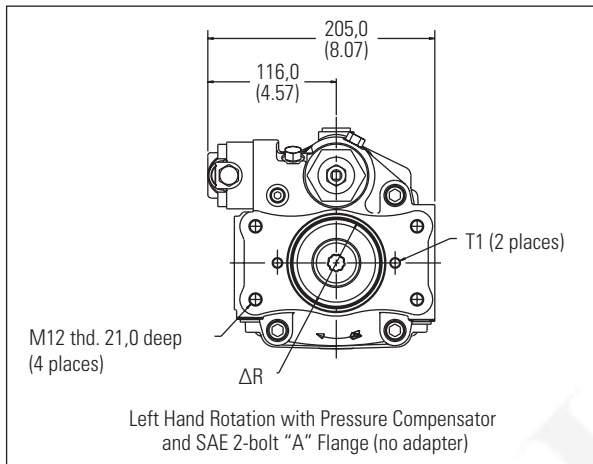

SAE .500-13
UNC-2B thd.
1.06 deep min.
ISO M12 x 1,75 thd.
29.0 deep min.

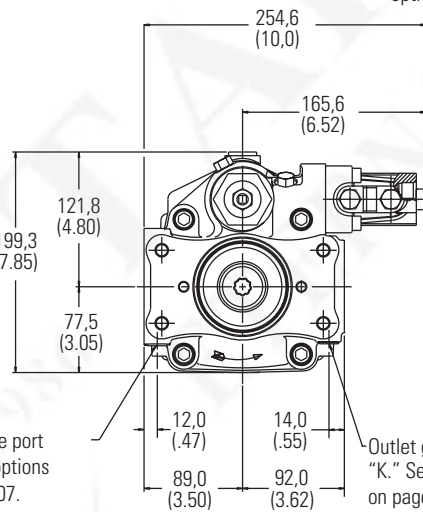
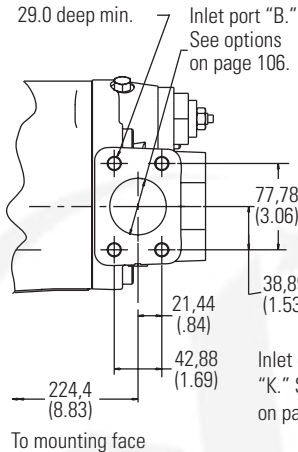

Right Hand Rotation with Load Sensing Control and SAE 2-bolt "A" Flange (no adapter)

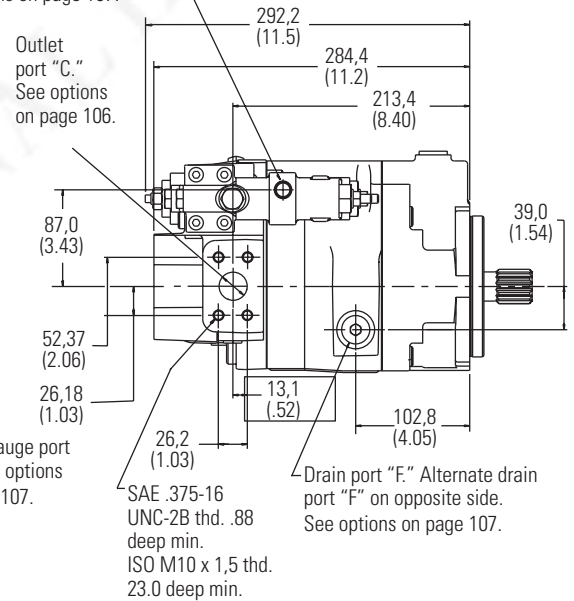

Dimensions in millimeters (inches)

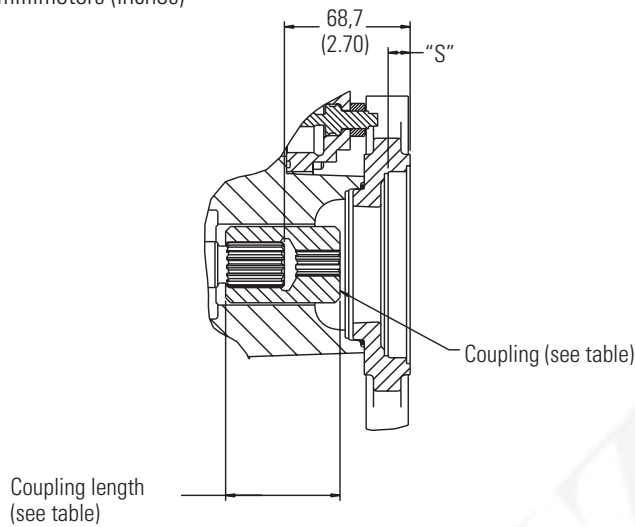

Coupling	Length	Code
SAE "A," 9T	62,5 (2.46)	A,G
SAE "B," 13T	93,0 (3.66)	C,J
SAE "B-B," 15T	93,0 (3.66)	D,K
SAE "C," 14T	93,0 (3.66)	E,L

"B" Adapter Flange

To mounting face

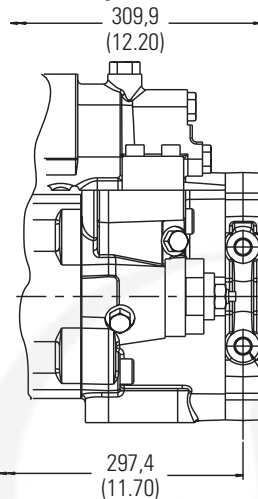

To mounting face

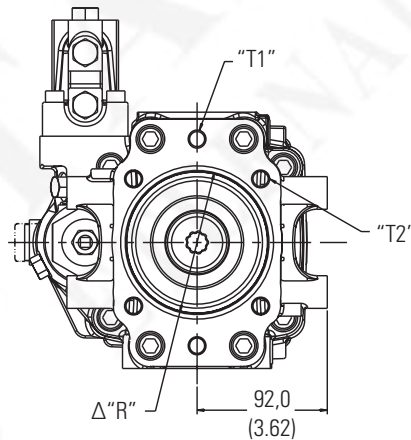

Right hand rotation with Load Sensing Control and

Model Code Position 25 Description

A	SAE "A," 9T, 16/32 DP, 30° pressure angle, involute spline
C	SAE "B," 13T, 16/32 DP, 30° pressure angle, involute spline
D	SAE "B-B," 15T, 16/32 DP, 30° pressure angle, involute spline
E	SAE "C," 14T, 12/24 DP, 30° pressure angle, involute spline
G	For ISO 80-A2HW pad with a 9T SAE spline
J	For ISO 100-A2/B4HW pad with a 13T SAE spline
K	For ISO 100-A2/B4HW pad with a 15T SAE spline
L	For ISO 125-A2/B4HW pad with a 14T SAE spline

Model Code	Position 25		Pilot Dia.	Pilot Depth	2-bolt	4-bolt	Support Mounting Points
	Flange	Bolt	"R"	"S"	"T1"	"T2"	"V"
A,B	SAE "A" 2-bolt	SAE	Ø82,65 (3.25±.001)	8,6/8,1 (.32/.34)	.375-16 UNC-2B thd.	N/A	N/A
G,H	ISO 80	ISO	Ø80,05 (3.15)	9,0/8,0 (.35/.31)	M10 thd.	N/A	N/A
C,D	SAE "B" 2-1/4-bolt	SAE	Ø101,65 (4.002±.001)	12,5/11,5 (.49/.45)	.50-13 UNC-2B thd.	.50-13 UNC-2B thd.	.50-13 UNC-2B thd. .98" deep
J,K	ISO 100	ISO	Ø100,05 (3.94)	12,5/11,5 (.49/.45)	M12 thd.	M12 thd.	M12 thd. x 25,0 deep

Dimensions in millimeters (inches)

"C" Adapter Flange

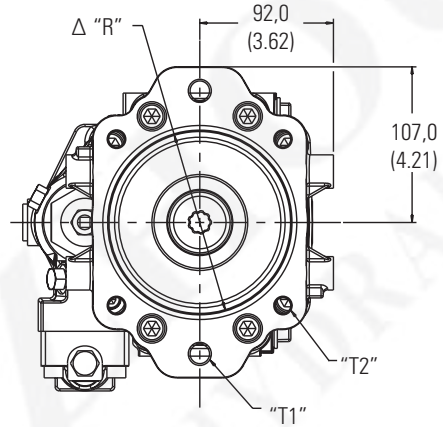
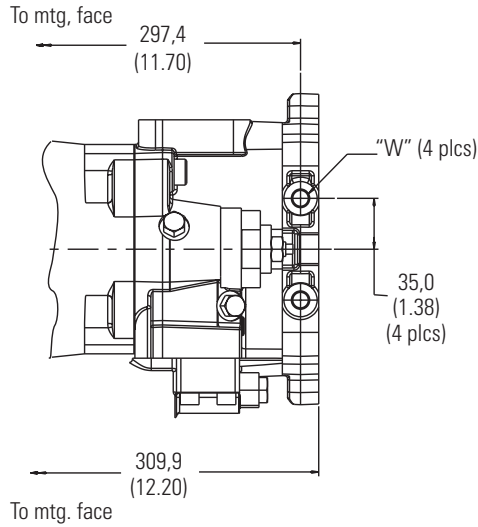

Left hand rotation with Pressure Compensator and
SAE 2-/4-bolt "C" Adapter Flange

Model Code	Position 25		Pilot Dia.	Pilot Depth	2-bolt	4-bolt	Support Mounting Points
	Flange	Bolt	"R"	"S"	"T1"	"T2"	"V"
E,F	SAE "C" 2-/4-bolt	SAE	Ø127,05 (5.002±.001)	15,5/14,5 (.61/.57)	.625-11 UNC-2B thd.	.50-13 UNC-2B thd.	.50-13 UNC-2B thd. .98" deep
L,M	ISO 125	ISO	Ø125,05 (4.92)	15,5/14,5 (.61/.57)	M16 thd.	M12 thd.	M12 thd. x 25,0 deep

Side-ported Models PVM074/081 *Right Hand Only

Dimensions in millimeters (inches)

See pilot flange options on page 101.
See shaft options starting on page 102.

Lifting point .375-16 UNC thd.
10.0 (.39) deep with SAE drain
M10 thd. 10.0 (.39) deep with ISO drain

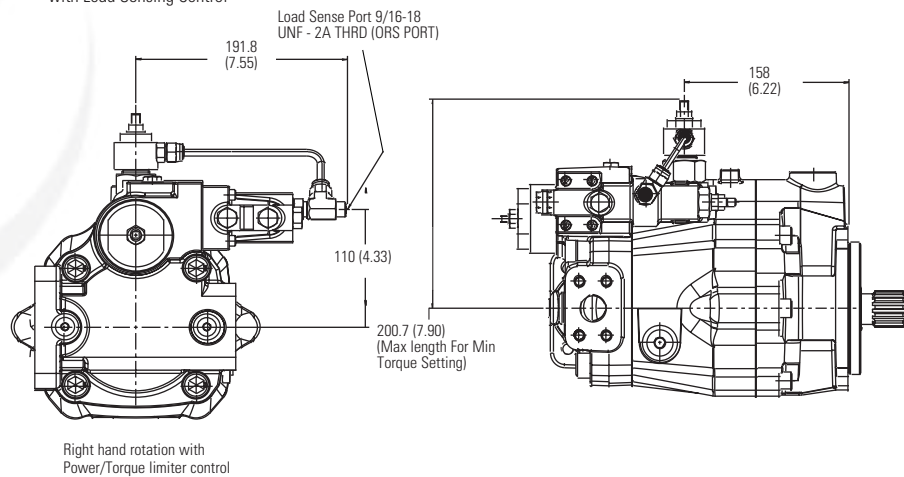
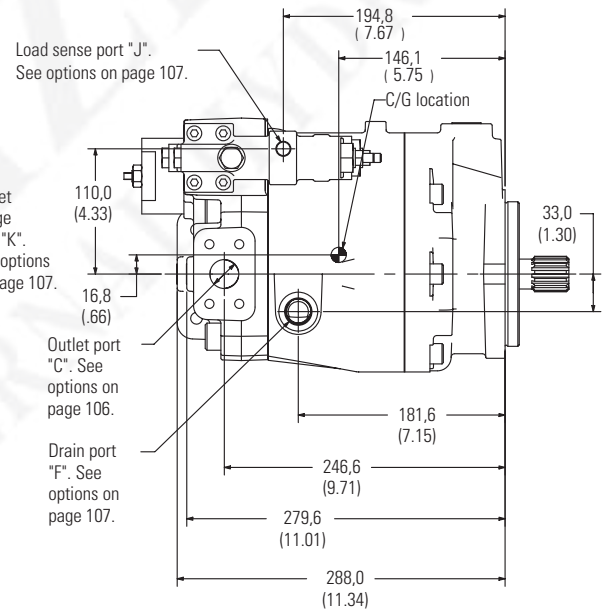
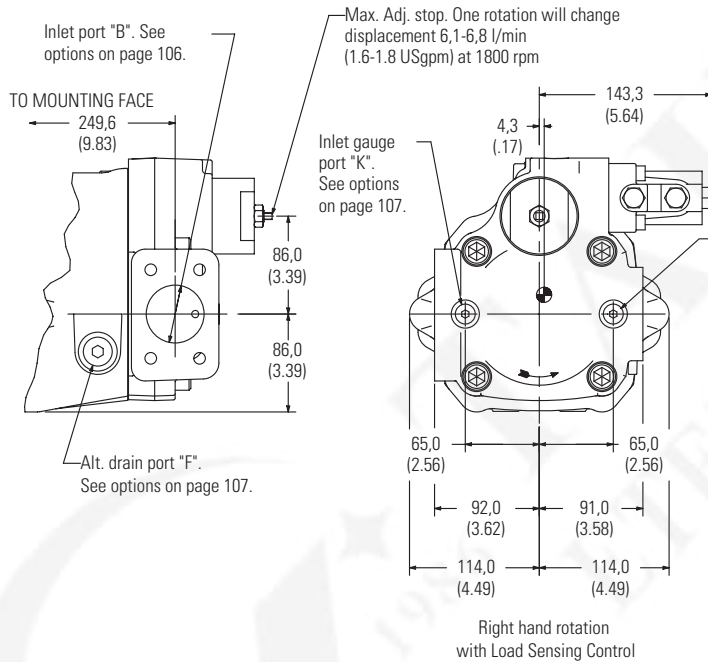
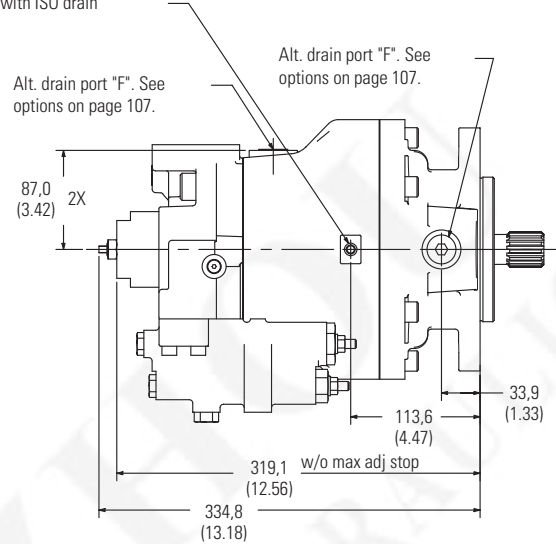
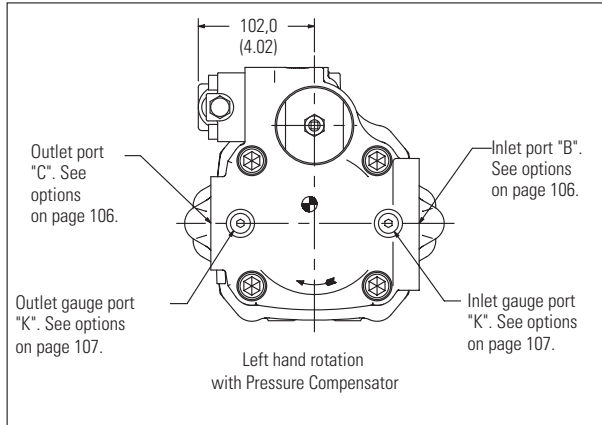

PVM074/108 is not available with left hand rotation in any port configuration.

Thru-drive Models

PVM074/081

*Right-hand only

Dimensions in millimeters (inches)

See pilot flange options on page 101.
See shaft options starting on page 102.

Lifting point .375-16 UNC thd.
10,0 (.39) deep with SAE drain
M10 thd. 10,0 (.39) deep with ISO drain

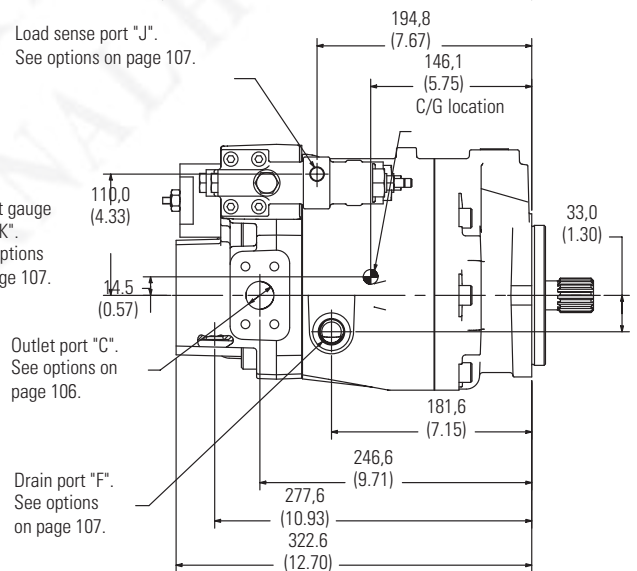
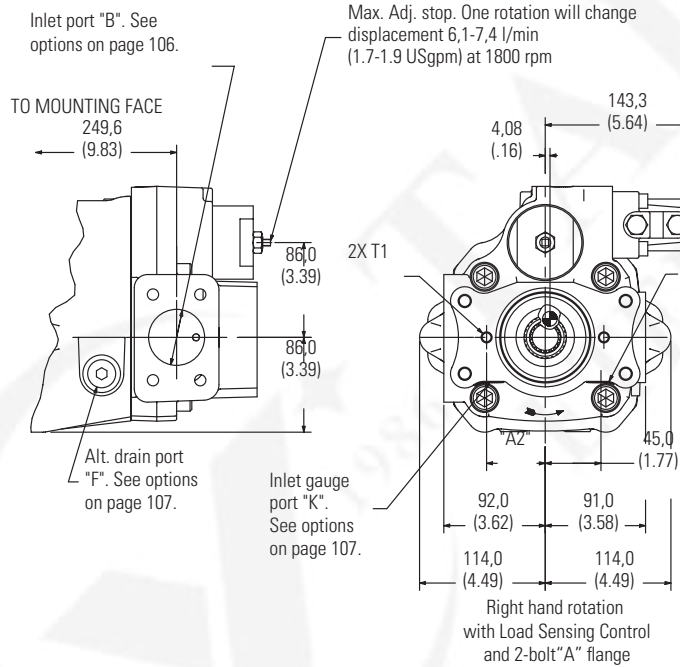
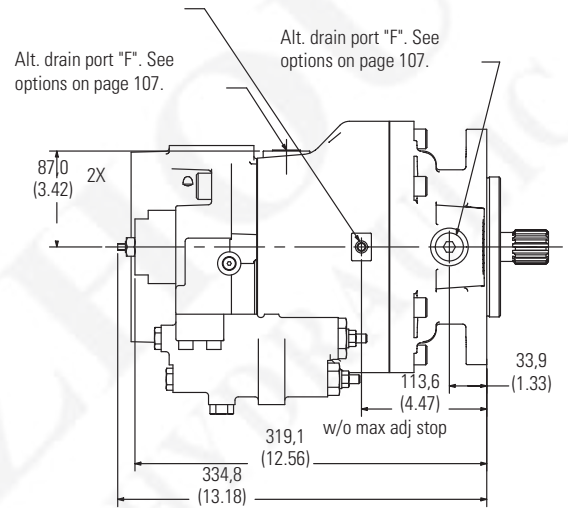
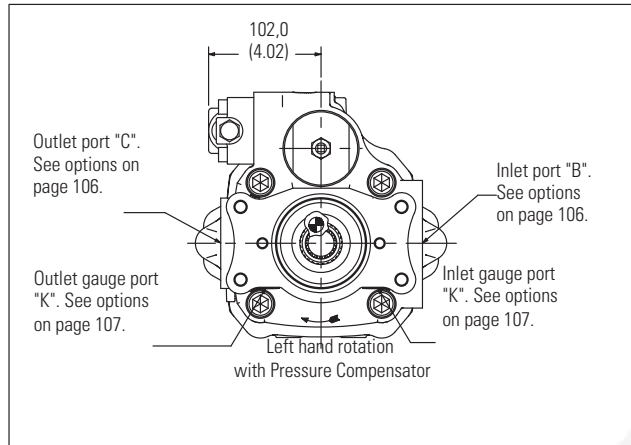

PVM074/108 is not available with left hand rotation in any port configuration.

Dimensions in millimeters (inches)

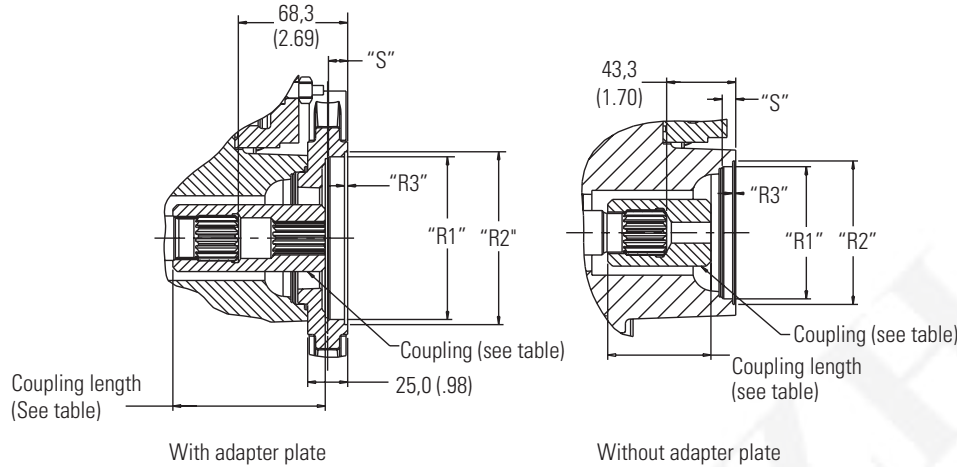

Coupling	Length	Code
SAE "A," 9T	64,5 (2.54)	A,G
SAE "A," 11T	65,3 (2.57)	B,H
SAE "B," 13T	95,3 (3.75)	C,J
SAE "B-B," 15T	95,3 (3.75)	D,K
SAE "C," 14T	95,3 (3.75)	E,L
SAE "C-C," 17T	91,8 (3.61)	F,M

Model code Position 25 Description

A	SAE "A," 9T, 16/32 DP, 30° pressure angle, involute spline
B	SAE "A," 11T, 16/32 DP, 30° pressure angle, involute spline
C	SAE "B," 13T, 16/32 DP, 30° pressure angle, involute spline
D	SAE "B-B," 15T, 16/32 DP, 30° pressure angle, involute spline
E	SAE "C," 14T, 12/24 DP, 30° pressure angle, involute spline
F	SAE "C-C," 17T, 12/24 DP, 30° pressure angle, involute spline
G	For ISO 80-A2HW pad with a 9T SAE spline
H	For ISO 80-A2HW pad with a 11 T SAE spline
J	For ISO 100-A2/B4HW pad with a 13T SAE spline
K	For ISO 100-A2/B4HW pad with a 15T SAE spline
L	For ISO 125-A2/B4HW pad with a 14T SAE spline
M	For ISO 125-A2/B4HW pad with a 17T SAE spline

"B" Adapter Flange

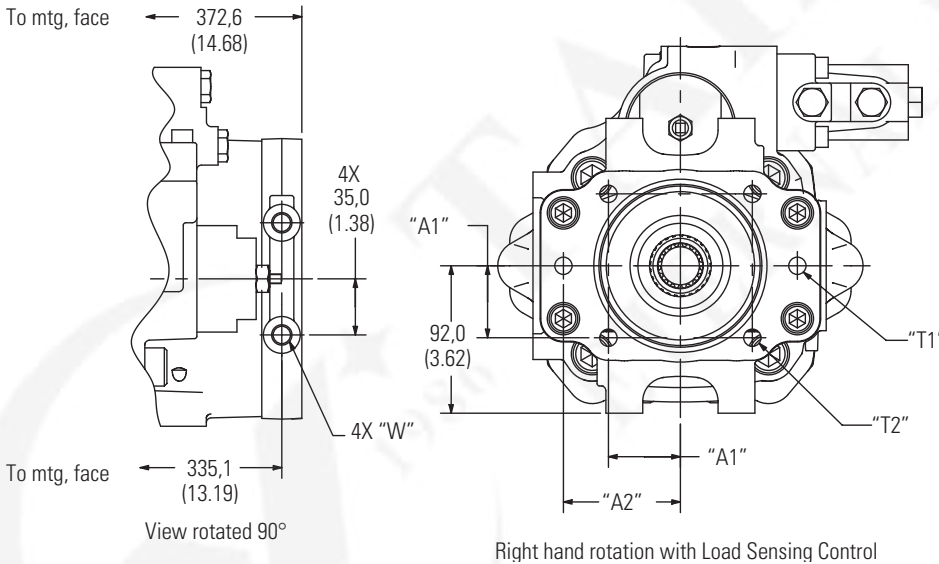

Model Code	Position 25 Flange Bolt		Pilot Dia.	O-ring Dia.	O-ring Depth	Pilot Depth	2-bolt	4-bolt	Support Mounting Points	4-bolt	2-bolt
	"A"	SAE	"R1"	"R2"	"R3"	"S"	"T1"	"T2"	"W"	"A1"	"A2"
A,B	SAE "A"	SAE	Ø82,6 (3.25)	Ø89,65 (3.53)	2,00 (.08)	9,0/8,0 (.35/.31)	375-16 UNC-2B thd.	N/A	N/A	N/A	53,2
G,H	2-bolt	ISO 80	Ø80,05 (3.15)	Ø89,75 (3.53)	2,70 (.11)	9,0/8,0 (.35/.31)	M10 thd.	N/A	N/A	N/A	54,5 (2.15)
C,D	SAE "B"	SAE	Ø101,65 (4.00)	Ø108,05 (4.25)	2,00 (.08)	12,5/11,5 (.49/.45)	.50-13 UNC-2B thd.	.50-13 UNC-2B thd.	.50-13 UNC-2B thd.	44,9 (2.87)	73,0
J,K	2-4-bolt	ISO 100	Ø100,05 (3.94)	Ø108,75 (4.28)	2,70 (.11)	12,5/11,5 (.49/.45)	M12 thd.	M10 thd.	M12 thd. 25,0 deep	44,19 (1.74)	70,0 (2.76)

Dimensions in millimeters (inches)

"C" Adapter Flange

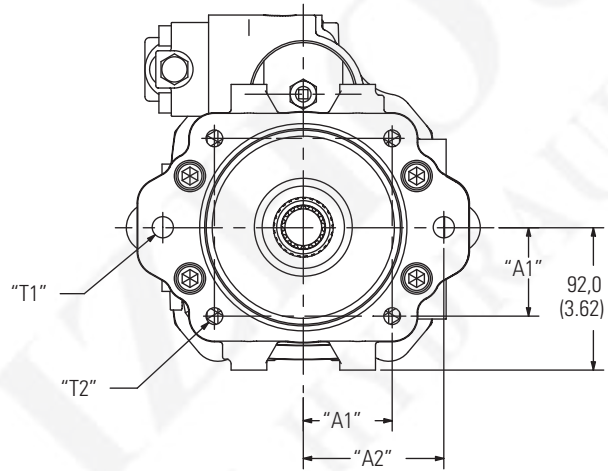
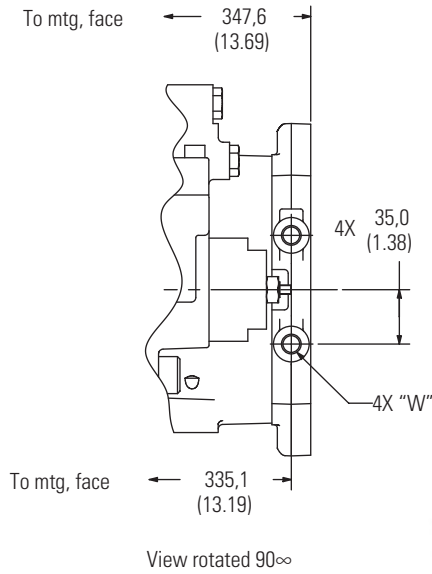

Left hand rotation with Pressure Compensator
and ISO or SAE 2-/4-bolt "C" Adapter Flange

Model Code	Position 25 Flange	Bolt	Pilot Dia.	O-ring Dia.	O-ring Depth	Pilot Depth	2-bolt		4-bolt		Support Mounting Points	
			"R1"	"R2"	"R3"	"S"	"T1"	"T2"	"W"	"A1"	"A2"	
E,F L,M	SAE "C"	SAE	Ø127,05	Ø133,45	2,00 (.08)	15,5/14,5	.625-11 UNC-2B thd.	.50-13 UNC-2B thd.	.50-13 UNC-2B thd.	.98" deep	57,25 (2.25)	90,5 (3.56)
	ISO 125	ISO	Ø125,05 (4.92)	Ø133,75 (3.26)	2,70 (.11) 2,60 (.10)	15,5/14,5 (6.1/5.7)	M16 thd.	M12 thd.	M12 thd.	25,0 deep	56,57 (2.23)	90,0 (3.54)

Side-ported Models

PVM098/106

Dimensions in millimeters (inches)

See pilot flange options on page 101.
See shaft options starting on page 102.

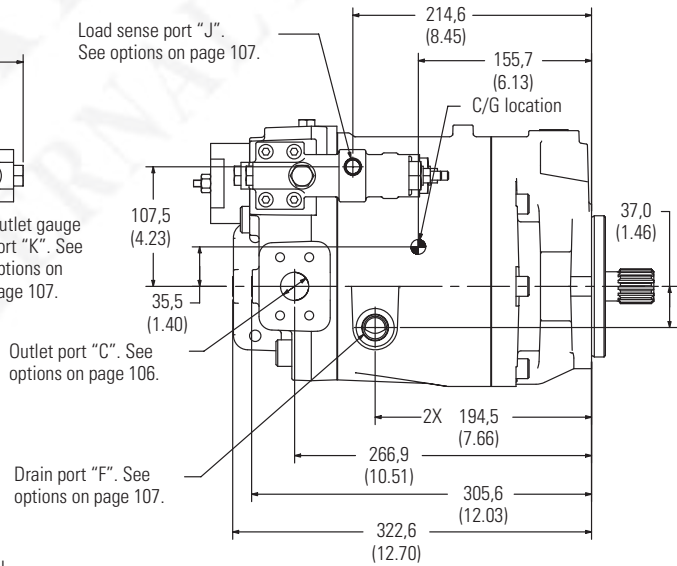
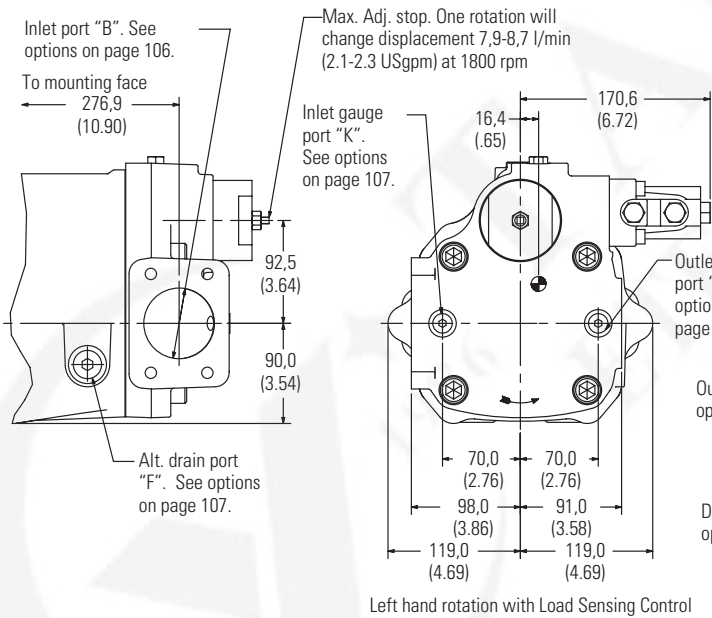
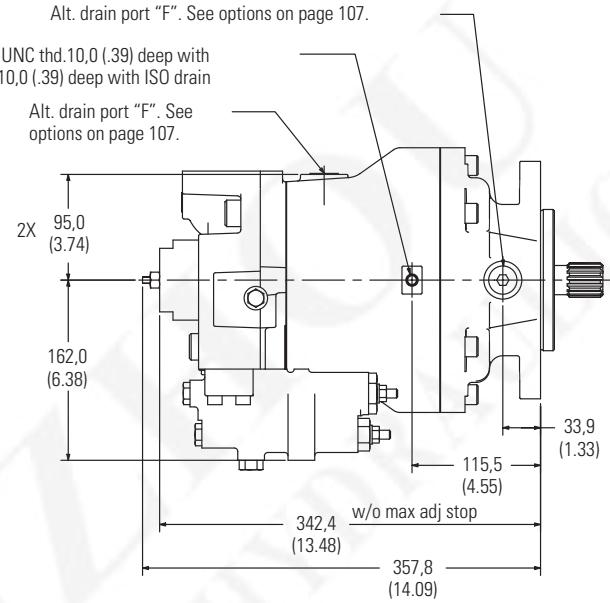
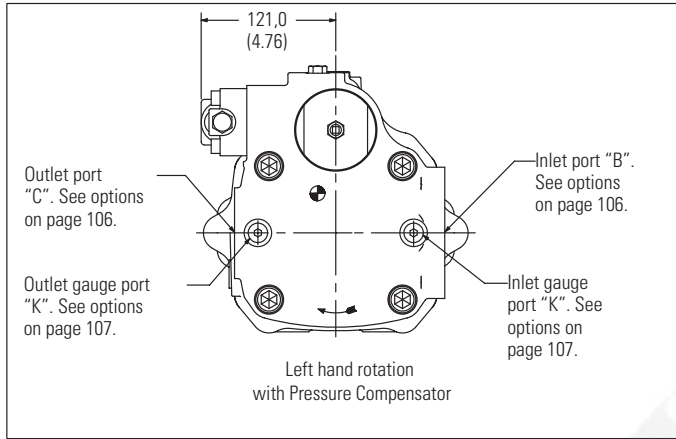

PVM098/106 is not available in left hand rotation with rear ports.

Thru-drive Models

PVM098/106

Dimensions in millimeters (inches)

See pilot flange options on page 101.
See shaft options starting on page 102.

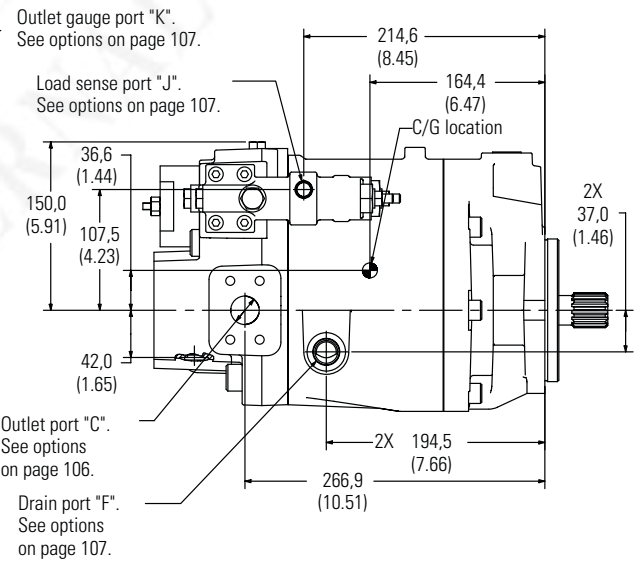
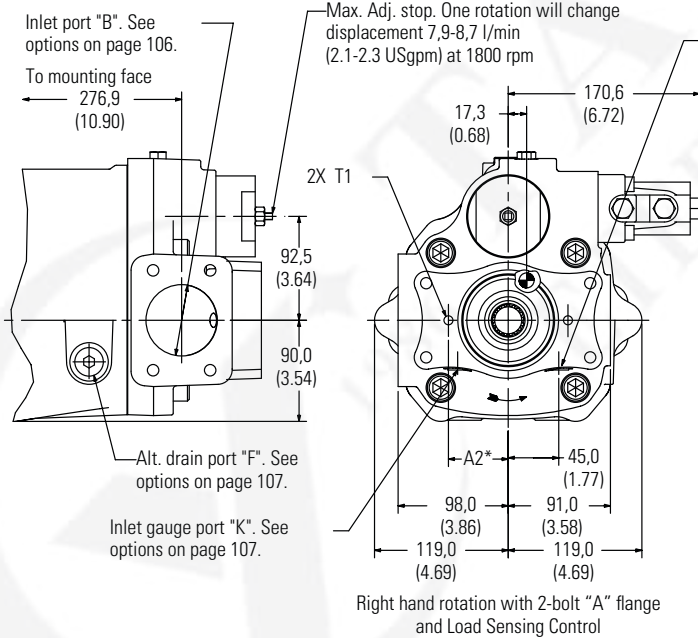
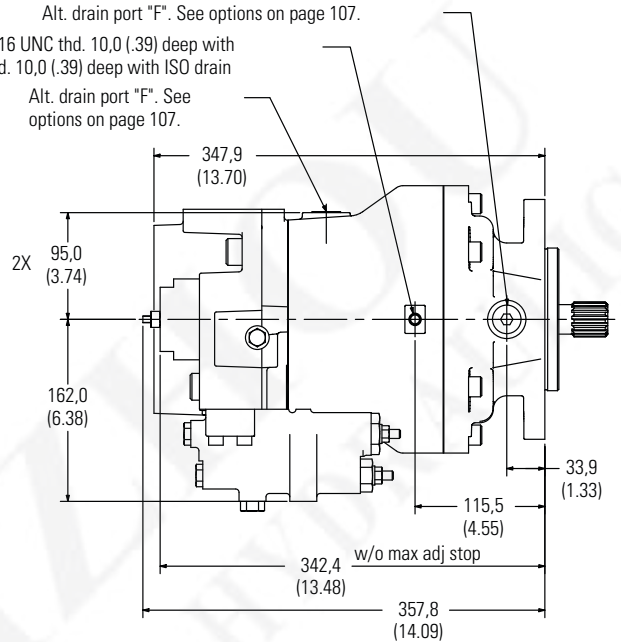
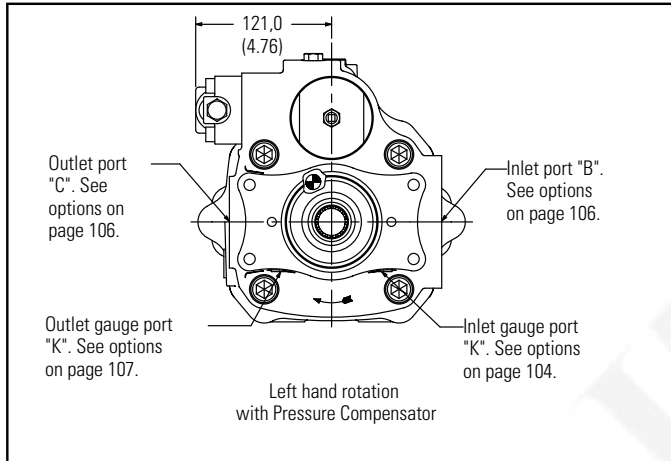

PVM098/106 is not available in left hand rotation with rear ports.

Dimensions in millimeters (inches)

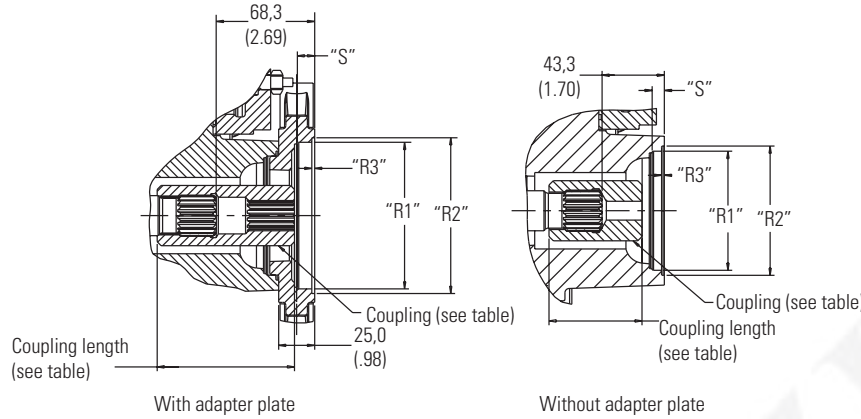

Coupling	Length	Code
SAE "A," 9T	64,5 (2.54)	A,G
SAE "A," 11T	65,3 (2.57)	B,H
SAE "B," 13T	95,3 (3.75)	C,J
SAE "B-B," 15T	95,3 (3.75)	D,K
SAE "C," 14T	95,3 (3.75)	E,L
SAE "C-C," 17T	91,8 (3.61)	F,M

Model Code Position 25
Description

A	SAE "A," 9T, 16/32 DP, 30° pressure angle, involute spline
B	SAE "A," 11T, 16/32 DP, 30° pressure angle, involute spline
C	SAE "B," 13T, 16/32 DP, 30° pressure angle, involute spline
D	SAE "B-B," 15T, 16/32 DP, 30° pressure angle, involute spline
E	SAE "C," 14T, 12/24 DP, 30° pressure angle, involute spline
F	SAE "C-C," 17T, 12/24 DP, 30° pressure angle, involute spline
G	For ISO 80-A2HW pad with a 9T SAE spline
H	For ISO 80-A2HW pad with a 11 T SAE spline
J	For ISO 100-A2/B4HW pad with a 13T SAE spline
K	For ISO 100-A2/B4HW pad with a 15T SAE spline
L	For ISO 125-A2/B4HW pad with a 14T SAE spline
M	For ISO 125-A2/B4HW pad with a 17T SAE spline

"B" Adaptor Flange

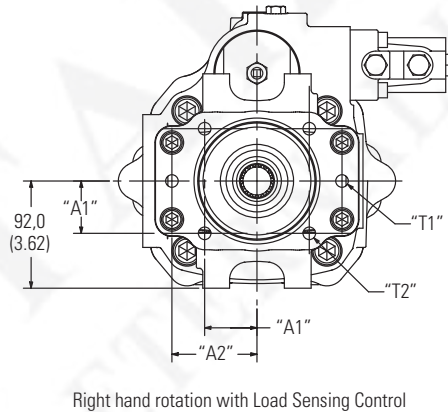
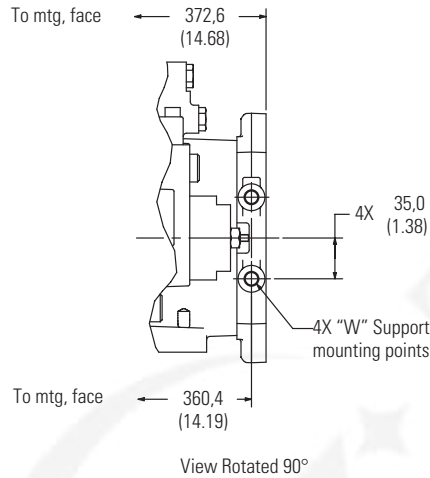

Model Code	Position 25 Flange Bolt	Pilot Dia.	O-ring			Pilot Depth	2-bolt		Support Mounting Points "W"	4-bolt	
			"R1"	"R2"	"R3"		"T1"	"T2"		"A1"	"A2"
A,B	SAE "A" SAE	Ø82,6 (3.25)	Ø89,65 (3.53)	2,00 (.08)	9,0/8,0 (.35/.31)	375-16 UNC-2B	N/A	N/A	N/A	53,2 (2.15)	
G,H	2-bolt ISO 80	Ø80,05 (3.15)	Ø89,75 (3.53)	2,70 (.11)	9,0/8,0 (.35/.31)	M10 thd. x 18,0 deep	N/A	N/A	N/A	54,5 (2.15)	
C,D	SAE "B" SAE	Ø101,65 (4.00)	Ø108,05 (4.25)	2,00 (.08)	12,5/11,5 (.49/.45)	.50-13 UNC-2B thd.	.50-13 UNC-2B thd.	.50-13 UNC-2B thd. .98" deep	44,9 (1.77)	73,0 (2.87)	
J,K	2-1/4-bolt ISO 100	Ø100,05 (3.94)	Ø108,75 (4.28)	2,70 (.11)	12,5/11,5 (.49/.45)	M12 thd.	M10 thd.	M12 thd. 25,0 deep	44,19 (1.74)	70,0 (2.76)	

Dimensions in millimeters (inches)

"C" Adapter Flange

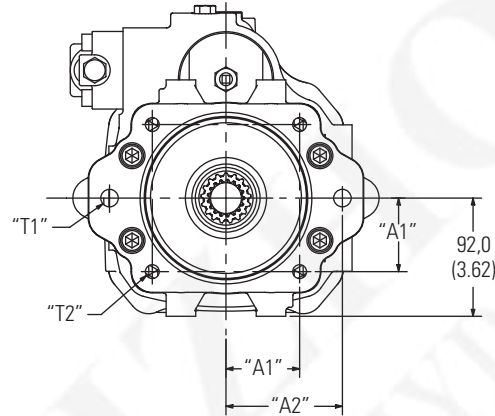
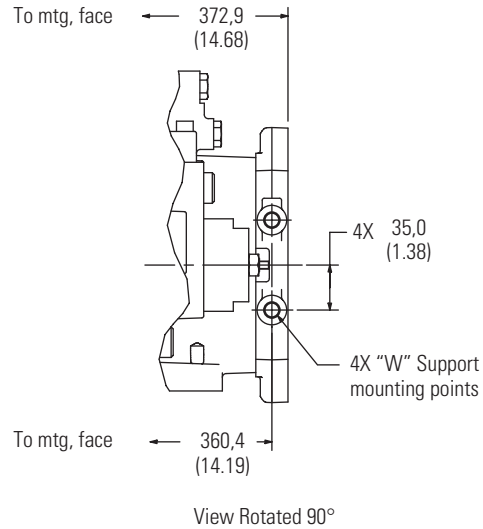

Left hand rotation **with Pressure Compensator and ISO or SAE 2-/4-bolt "C" adapter flange**

Model Code	Position 25 Flange	Bolt	Pilot Dia.	O-ring		Pilot Depth	Support Mounting Points				
			"R1"	"R2"	"R3"	"S"	"T1"	"T2"	"W"	"A1"	"A2"
E,F L,M	SAE "C"	SAE	Ø127,05	Ø133,45	2,00 (.08)	15,5/14,5	.625-11 UNC-2B thd.	.50-13 UNC-2B thd.	.50-13 UNC-2B thd. .98" deep	57,25 (2.25)	90,5 (3.56)
	ISO 125	ISO	Ø125,05 (4.92)	Ø133,75 (3.26)	2,70 (.11) 2,60 (.10)	15,5/14,5 (.61/.57)	M16 thd.	M12 thd.	M12 thd. 25,0 deep	56,57 (2.23)	90,0 (3.54)

End-ported Models

PVM131/141

Dimensions in millimeters (inches)

See pilot flange options on page 101.

See shaft options starting on page 102.

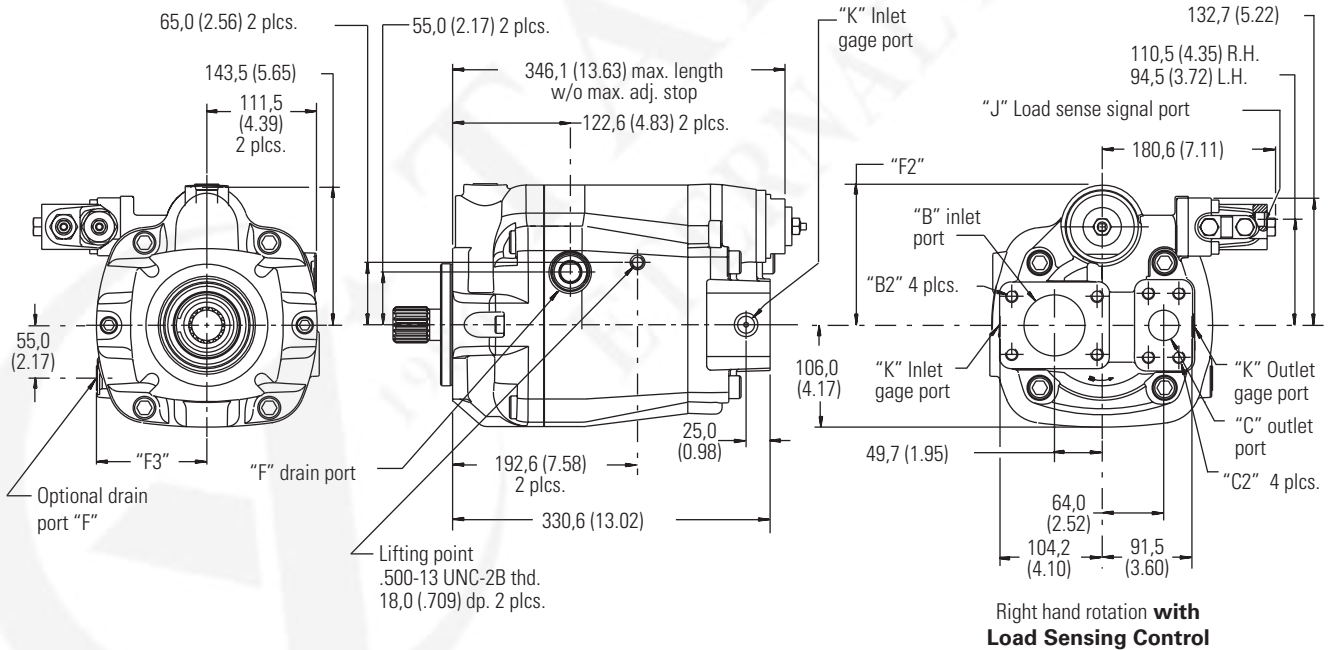
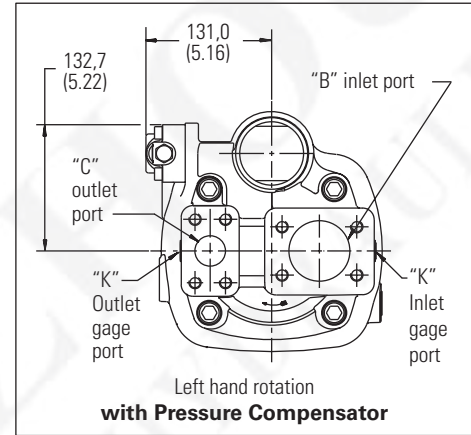
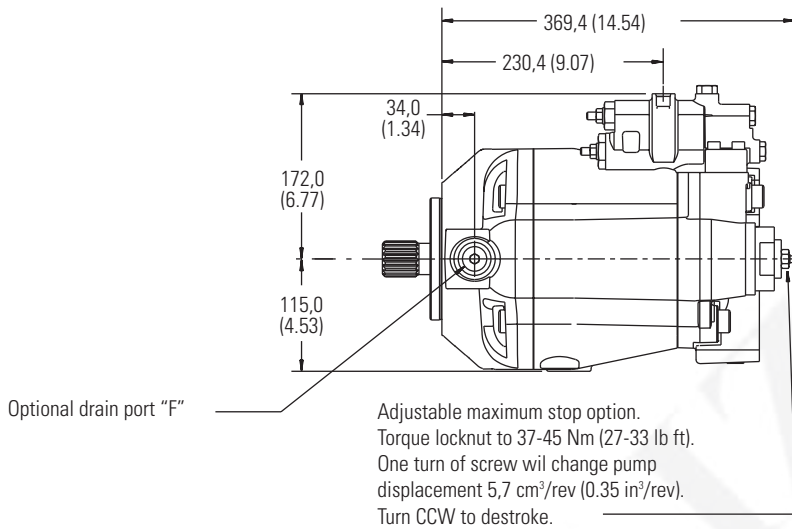

Side-ported Models

PVM131/141

Dimensions in millimeters (inches)

See pilot flange options on page 101.

See shaft options starting on page 102.

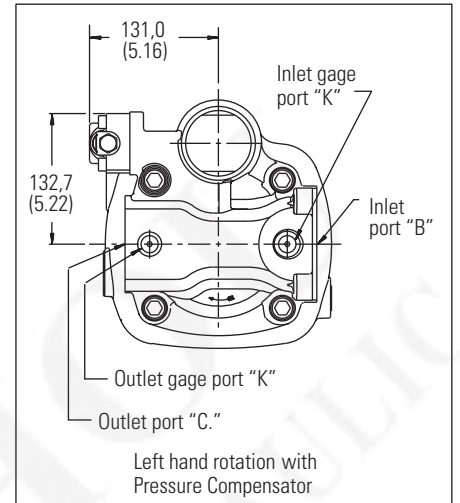
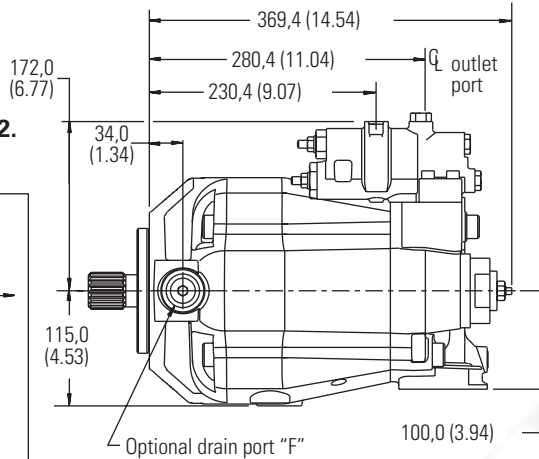
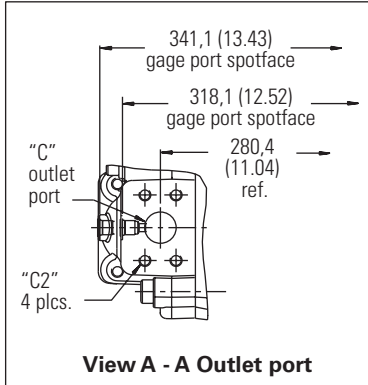

Adjustable maximum stop option.
Torque locknut to 37-45 Nm (27-33 lb ft).
One turn of screw will change pump displacement 5,7 cm³/rev (0.35 in³/rev)

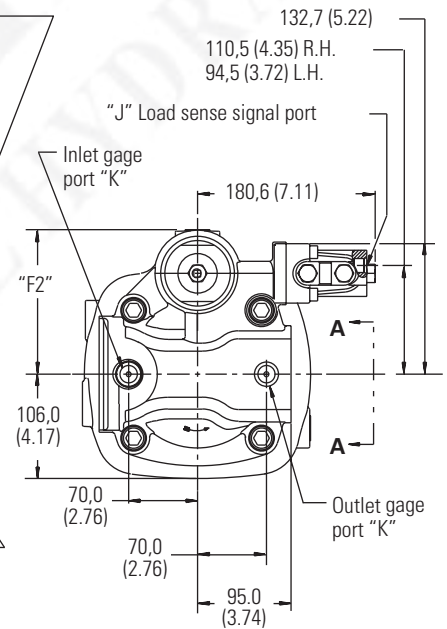
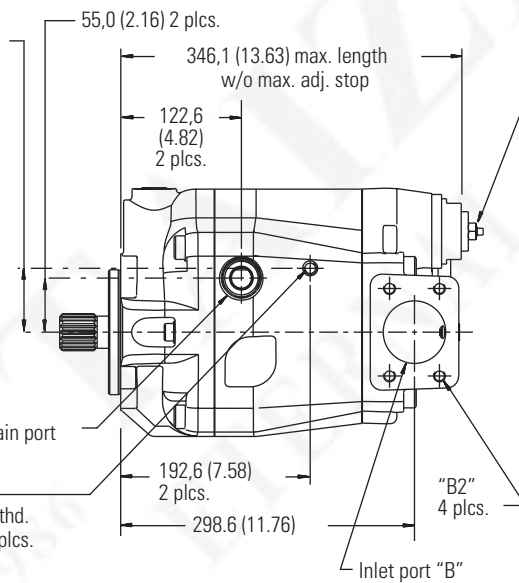
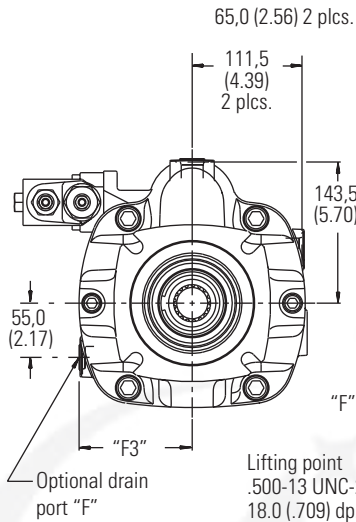

Lifting point
.500-13 UNC-2B thd.
18.0 (.709) dp. 2 plcs.

Right hand rotation with Load Sensing Control

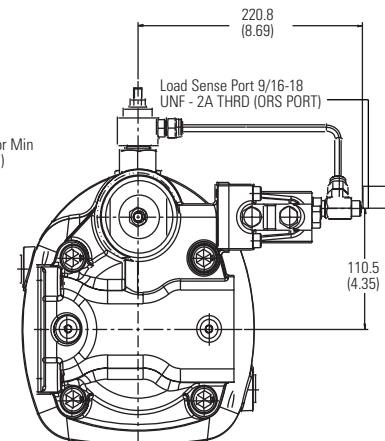
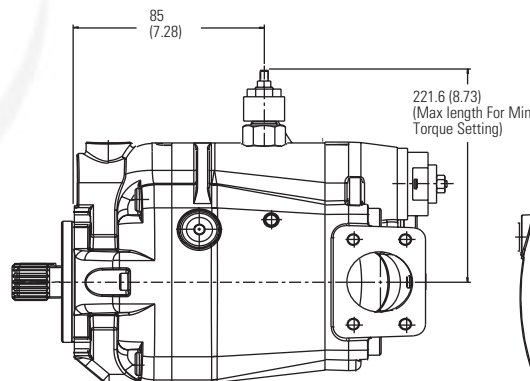

Right hand rotation with Power/Torque limiter control

Thru-drive Models

PVM131/141

Dimensions in millimeters (inches)

See pilot flange options on page 101.

See shaft options starting on page 102.

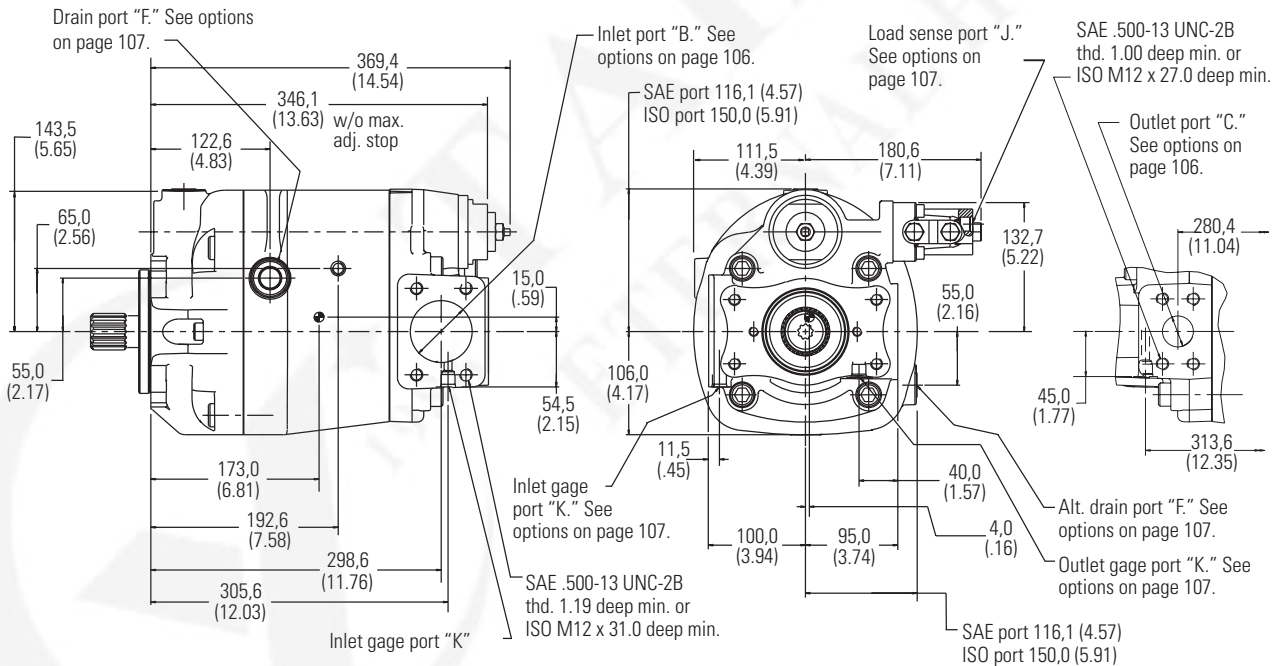
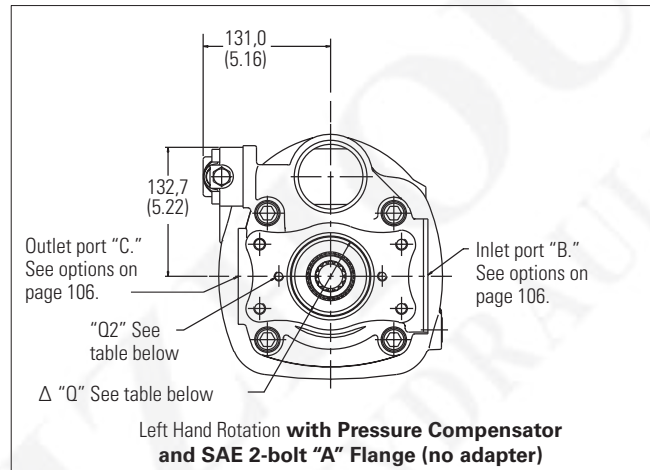
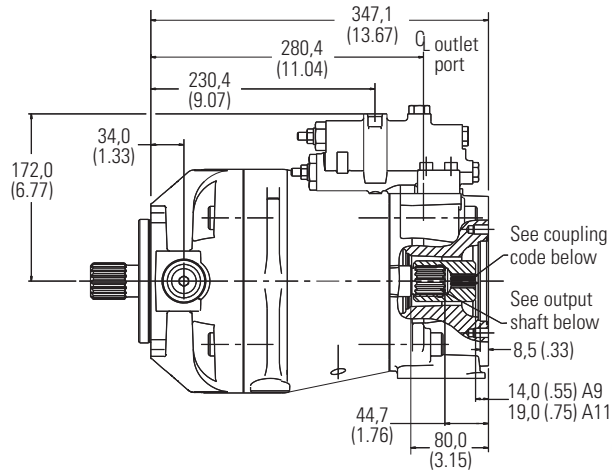

Right Hand Rotation with Load Sensing Control and SAE 2-bolt "A" Flange (no adapter)

Model Code	Position 25	"Q1" Thru-drive Flange	"Q2" 2-bolt Thread
A,B		SAE J744-82-2 Ø82.625/82.575 bore	.375-16 UNC-2B thd. 0.80 deep
G,H		ISO 3019/2-80A2 Ø80.075/80.25 bore	M10 thd. x 18,0 deep

Dimensions in millimeters (inches)

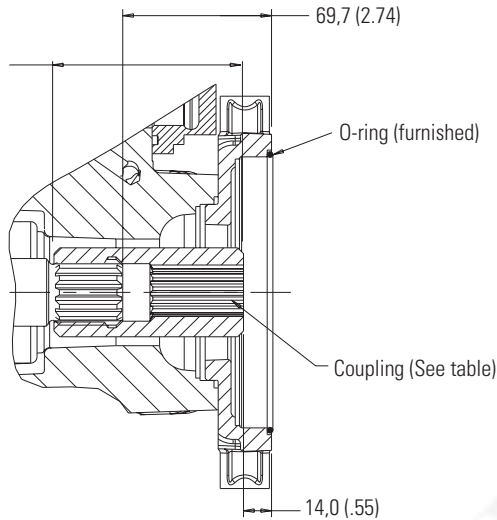

Model Code Position 25

Model Code	Description
A	For SAE "A" pad with a 9T, 16/32 DP, 30° pressure angle, involute spline
B	For SAE "A" pad with a 11T, 16/32 DP, 30° pressure angle, involute spline
Output shaft	14T 12/24 DP external involute spline
C	SAE "B," 13T, 16/32 DP, 30° pressure angle, involute spline
D	SAE "B-B," 15T, 16/32 DP, 30° pressure angle, involute spline
E	SAE "C," 14T, 12/24 DP, 30° pressure angle, involute spline
F	SAE "C-C," 17T, 12/24 DP, 30° pressure angle, involute spline
G	For ISO 80-A2HW pad with a 9T SAE spline
H	For ISO 80-A2HW pad with a 11T SAE spline
J	For ISO 100-A2/B4HW pad with a 13T SAE spline
K	For ISO 100-A2/B4HW pad with a 15T SAE spline
L	For ISO 125-A2/B4HW pad with a 14T SAE spline
M	For ISO 125-A2/B4HW pad with a 17T SAE spline

"B" Adapter Flange

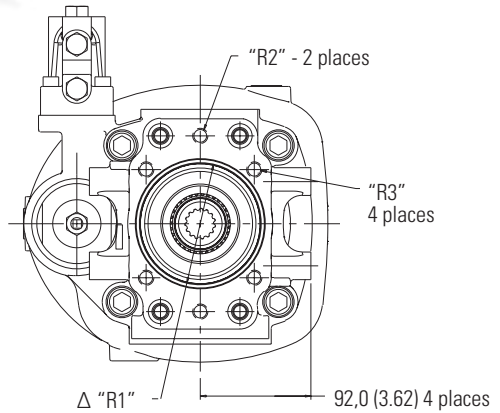
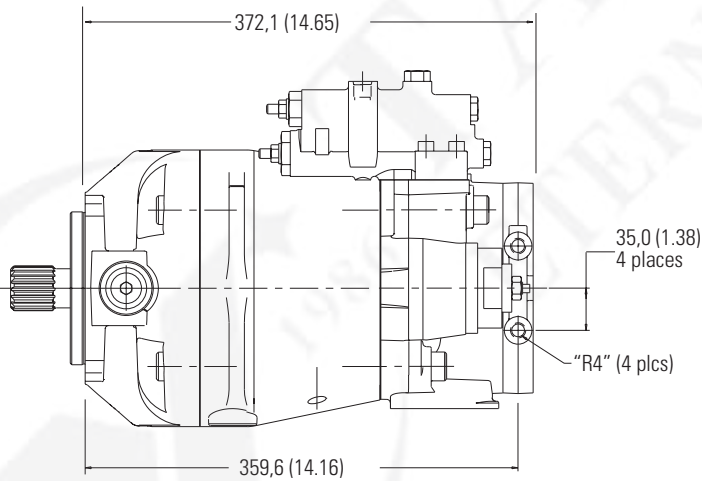

Right Hand Rotation with SAE 2-/4-Bolt "B" Flange and ISO 100 Adapter Flange

Model Code	"R1" Thru-drive Flange	"R2" 2-bolt Thread	"R3" 4-bolt Thread	"R4" Support Mounting Points
C,D	SAE J744-101-2 & -4 Ø101,675/101.625 bore 12,50/11,50 deep	.500-13 UNC-2B 0,98 deep	.500-13 UNC-2B 0,98 deep	.500-13 UNC-2B 0,98 deep
J,K	ISO 3019/2-100A2 & B2 Ø100,075/100.025 bore 12,50/11,50 deep	M12 25,0 deep	M12 25,0 deep	M12 25,0 deep

Dimensions in millimeters (inches)

"C" Adapter Flange

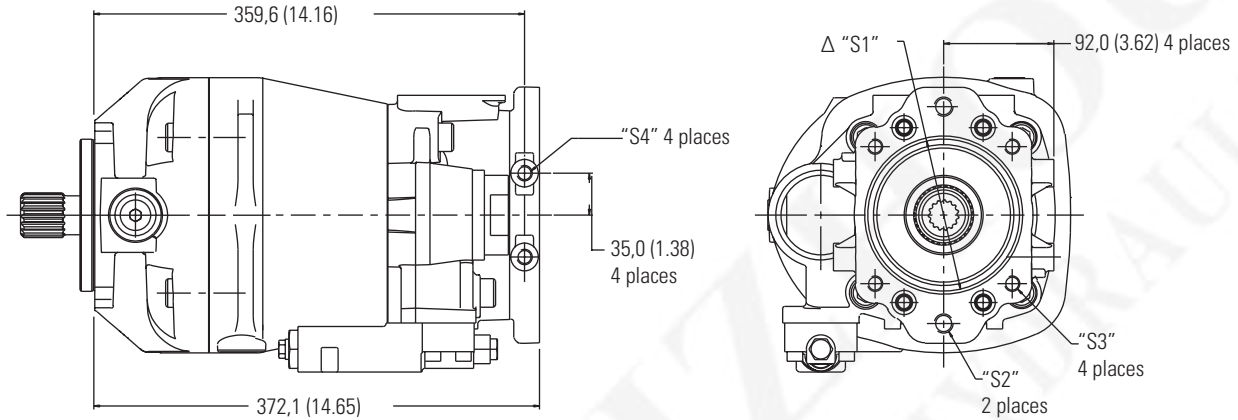

Left Hand Rotation with SAE 2-1/4-bolt "C" and ISO 125 Adapter Flange

Model Code

Position 25	"S1" Thru-drive Flange	"S2" 2-bolt Thread	"S3" 4-bolt Thread	"R4" Support Mounting Points
E,F	SAE J744-127-2 & -4 Ø127,075/127.025 bore 15,50/14,50 deep	.625-11 UNC-2B 0.98 deep	.500-13 UNC-2B 0.98 deep	.500-13 UNC-2B 0.98 deep
L,M	ISO 3019/2-125A2 & B4 Ø125,075/125.025 bore 15,50/14,50 deep	M16 25,0 deep	M12 25,0 deep	M12 25,0 deep

Port	"B"*	"B2"	"C"*	"C2"	"F2"	"F3"
SAE	2.50 inch dia. SAE J518 Code 61, low pressure	.500-13 UNC-2B thd. 1.19 deep minimum	1.25 inch dia. SAE J518 Code 62, high pressure	.500-13 UNC-2B thd. 1.00 deep minimum	146,8 (5.78)	114,9 (4.52)
ISO	64mm diameter. ISO 6162 Type II, 315 bar	M12 thread 31,0 deep minimum	32mm diameter. ISO 6162, 400 bar	M12 thread 27,0 deep minimum	148,5 (5.85)	116,6 (4.59)

*4-bolt flange port. See page 101 for load sensing, drain, and gage port threads.

Mounting Flange Options

Dimensions in millimeters (inches)

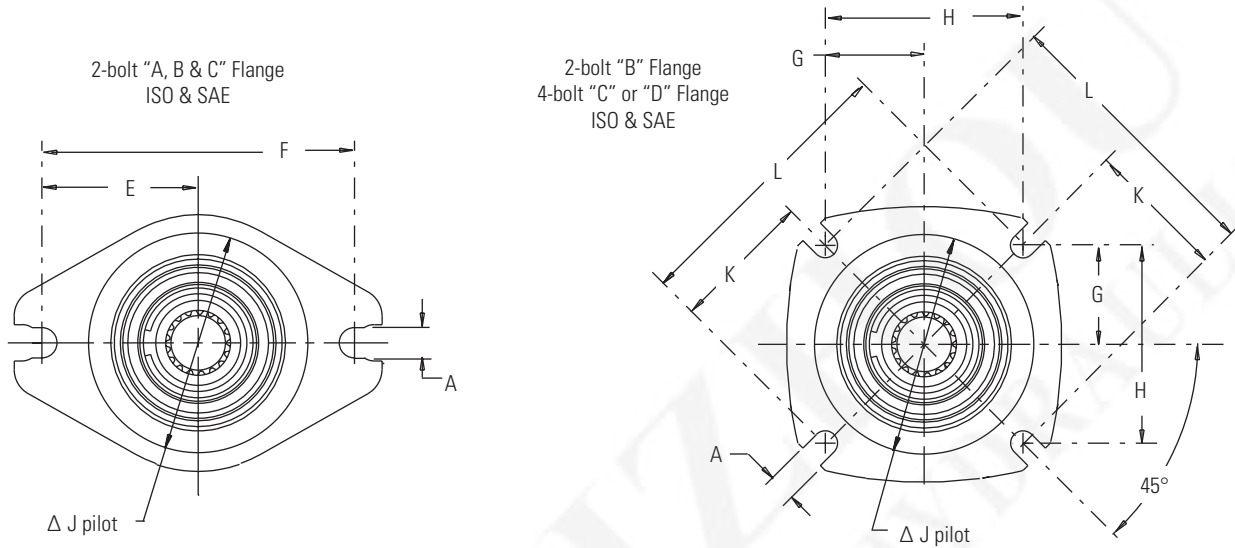

Series	2-bolt or 4-bolt Flange	Code	Flange Description	A	E	F	G	H	J	K	L
PVM018	2-bolt	A	SAE J744-82-2	Ø11,14	53,2	106,4	-	-	Ø82,53 +.02 -.03	-	-
PVM020	"A"			(4.38)	(2.09)	(4.19)	-	-	(Ø3.249) +.000 -.001	-	-
PVM018	2-bolt	B	ISO 3019/2-80A2HW	Ø11,14	54,5	109,0	-	-	Ø79,98 +.02 -.03	-	-
PVM020	"A"			(4.38)	(2.15)	(4.29)	-	-	(Ø3.15) +.000 -.001	-	-
PVM018	2-bolt "B"	C	SAE J744-101-2	14,36	73,0	146,0	-	-	Ø101,58+.02 -.03	-	-
PVM020											
PVM045											
PVM050											
PVM057											
PVM063											
PVM018	2-bolt "B" (special)	D	ISO 3019/2-100A2HW	14,14	70,0	140,0	-	-	Ø100,00/99,95 (Ø3.937/3.935)	-	-
PVM020											
PVM045											
PVM050											
PVM057											
PVM063											
PVM057	2-bolt "C"	E	SAE J744-127-2 ("C")	17,4	90,5	181,0	-	-	Ø127,00/126,95 (Ø5.000/4.998)	-	-
PVM063											
PVM074	2-bolt "C"	F	ISO 3019/2-125A2HW	18,0	90,0	180,0	-	-	Ø125,00/124,95 (Ø4.921/4.919)	-	-
PVM081											
PVM098	4-bolt "C"	G	SAE J744-127-4 ("C")	14,2	-	-	57,25	114,50	Ø127,00/126,95 (Ø5.000/4.998)	-	-
PVM106											
PVM131											
PVM141											
PVM131	4-bolt "D"	J	SAE J744-152-4 ("D")	20,6	-	-	80,82	161,64	Ø152,40/152,35 (Ø6.000/5.998)	-	-
PVM141											
		K	ISO 3019/2-160B4HW	18,0	-	-	-	-	Ø160,00/159,95 (Ø6.299/6.297)	100,0	200,0
				(.709)						(3.937)	(7.874)

*Flanges for PVM020 and PVM050 are shown on pages 73 and 80, respectively.

Shaft Options

Dimensions in millimeters (inches)

SAE Splined Shaft

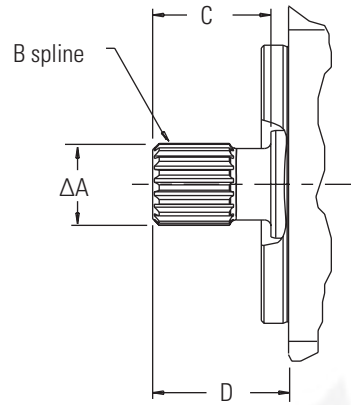

Model Series	SAE Spline Shaft Designation	Shaft Code	A max.	B	C	D	Max. Input Torque Nm (lb. in.)
PVM018/020	SAE J744-16-4 SAE "A" (9T)	03	15,88 (.625)	9T 16/32 DP	37,0 (1.46)	32,0 (1.26)	58 (517)
	SAE J744-19-4 SAE "A" (11T)	04	19,05 (.750)	11T 16/32 DP	30,0 (1.18)	38,0 (1.50)	123 (1100)
	SAE J744-22-4 SAE "B" (13T)	07	21,81 (.859)	13T 16/32 DP	33,0 (1.31)	41,0 (1.61)	208 (1850)
	SAE J744-25-4 SAE "B-B" (15T)	08	24,98 (.983)	15T 16/32 DP	38,0 (1.50)	46,0 (1.81)	337 (2987)
PVM045/050	SAE J744-22-4 SAE "B" (13T)	07	21,81 (.859)	13T 16/32 DP	33,0 (1.31)	41,0 (1.61)	208 (1850)
	SAE J744-25-4 SAE "B-B" (15T)	08	24,98 (.983)	15T 16/32 DP	38,0 (1.50)	46,0 (1.81)	337 (2987)
PVM057/063	SAE J744-22-4 SAE "B" (13T)	07	21,81 (.859)	13T 16/32 DP	33,0 (1.31)	41,0 (1.61)	208 (1850)
	SAE J744-25-4 SAE "B-B" (15T)	08	24,98 (.983)	15T 16/32 DP	38,0 (1.50)	46,0 (1.81)	337 (2987)
PVM074/081 PVM098/106	SAE J744-32-4 SAE "C" (14T)	11	31,22 (1.23)	14T 12/24 DP	48,0 (1.89)	56,0 (2.20)	640 (5660)
	SAE J744-38-4 SAE "C-C" (17T)	12	37,57 (1.479)	17T 12/24 DP	54,0 (2.13)	62,0 (2.44)	1215 (10,750)
PVM131/141	SAE J744-32-4 SAE "C" (14T)	11	31,22 (1.23)	14T 12/24 DP	48,0 (1.89)	56,0 (2.20)	640 (5660)
	SAE J744-38-4 SAE "C-C" (17T)	12	37,57 (1.479)	17T 12/24 DP	54,0 (2.13)	62,0 (2.44)	1215 (10,750)
	SAE J744-44-4 SAE "D" (13T)	14	43,71 (1.721)	13T 8/16 DP	67,0 (2.63)	75,0 (2.95)	1215 (10,750)

Dimensions in millimeters (inches)

SAE Keyed Shaft

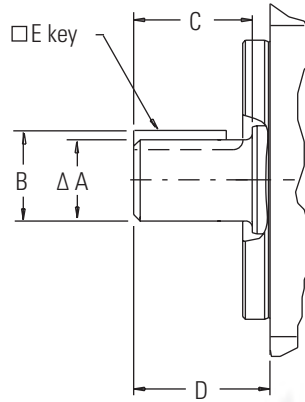

Model Series	SAE Keyed Shaft Designation	Shaft Code	A	B	C	D	E	Max. Input Torque Nm (lb. in.)
PVM018/020	SAE J744-16-1 SAE "A"	01	15,88 (.625)	17,73 (.698)	24,0 (.94)	32,0 (1.26)	4,0 (.157)	58 (517)
	SAE J744-19-1 SAE "19-1"	02	19,05 (.750)	21,23 (.836)	24,0 (.94)	32,0 (1.26)	4,81 (.189)	104 (918)
	SAE J744-22-1 SAE "B"	05	22,22 (.875)	25,12 (.989)	33,0 (1.31)	41,0 (1.61)	6,35 (.250)	135 (1200)
	SAE J744-25-1 SAE "B-B"	06	25,37 (.999)	28,22 (1.111)	38,0 (1.50)	46,0 (1.81)	6,35 (.250)	215 (1900)
PVM045/050	SAE J744-22-1 SAE "B"	05	22,22 (.875)	25,12 (.989)	33,0 (1.31)	41,0 (1.61)	6,35 (.250)	135 (1200)
	SAE J744-25-1 SAE "B-B"	06	25,37 (.999)	28,22 (1.111)	38,0 (1.50)	46,0 (1.81)	6,35 (.250)	215 (1900)
PVM057/063	SAE J744-25-1 SAE "B-B"	06	25,37 (.999)	28,22 (1.111)	38,0 (1.50)	46,0 (1.81)	6,35 (.250)	215 (1900)
	SAE J744-32-1 SAE "C"	09	31,75 (1.25)	35,32 (1.390)	48,0 (1.89)	56,0 (2.20)	7,93 (.312)	450 (3980)
PVM074/081 PVM098/106	SAE J744-32-1 SAE "C"	09	31,75 (1.25)	35,32 (1.390)	48,0 (1.89)	56,0 (2.20)	7,93 (.312)	450 (3980)
	SAE J744-38-1 SAE "C-C"	10	38,10 (1.50)	42,39 (1.67)	54,0 (2.13)	62,0 (2.44)	9,52 (.375)	765 (6770)
PVM131/141	SAE J744-32-1 SAE "C"	09	31,75 (1.25)	35,32 (1.390)	48,0 (1.89)	56,0 (2.20)	7,93 (.312)	450 (3980)
	SAE J744-38-1 SAE "C-C"	10	38,10 (1.50)	42,39 (1.67)	54,0 (2.13)	62,0 (2.44)	9,52 (.375)	765 (6770)
	SAE J744-44-1 SAE "D"	13	44,45 (1.75)	49,46 (1.95)	67,0 (2.63)	75,0 (2.95)	11,11 (.438)	1200 (10,620)

Dimensions in millimeters (inches)

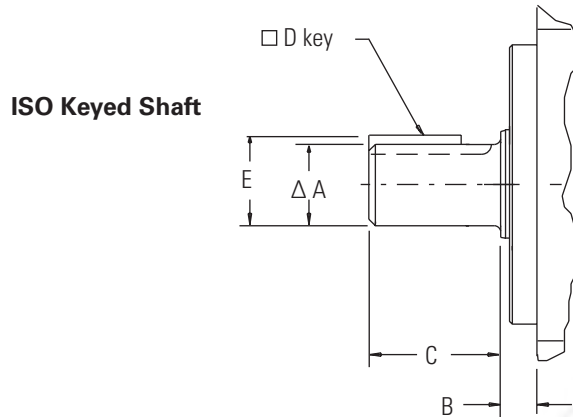

Model Series	ISO Keyed Shaft Designation	Shaft Code	A	B	C	D	E	Max. Input Torque Nm (lb. in.)
PVM018/020	ISO 3019/2 E20N 15		19,9 (.786)	8,5 (.335)	36 (1.42)	6 (.236)	22,5 (.886)	113 (1000)
	ISO 3019/2 E25N Short Spigot	16	25 (.984)	8,5 (.335)	42 (1.65)	8 (.315)	28,0 (1.102)	215 (1900)
	ISO 3019/2 E25N 17		25 (.984)	10 (.393)	42 (1.65)	8 (.315)	28,0 (1.102)	215 (1900)
PVM045/050	ISO 3019/2 E25N 17		25 (.984)	10 (.393)	42 (1.65)	8 (.315)	28,0 (1.102)	215 (1900)
PVM057/063	ISO 3019/2 E25N 17		25 (.984)	10 (.393)	42 (1.65)	8 (.315)	28,0 (1.102)	215 (1900)
	ISO 3019/2 E32N 18		32 (1.26)	10 (.393)	58 (2.28)	10 (.394)	35,0 (1.378)	450 (3980)
PVM074/081	ISO 3019/2 E32N 18		32 (1.26)	10,5 (.413)	58 (2.28)	10 (.394)	35,0 (1.378)	450 (3980)
PVM098/106	ISO 3019/2 E40N 19		40 (1.57)	10,5 (.413)	82 (3.23)	12 (.472)	43,0 (1.693)	870 (7700)
PVM131/141	ISO 3019/2 E32N 18		32 (1.26)	10 (.393)	58 (2.28)	10 (.394)	35,0 (1.378)	450 (3980)
	ISO 3019/2 E40N 19		40 (1.57)	10 (.393)	82 (3.23)	12 (.472)	43,0 (1.693)	870 (7700)

□ ISO 80mm pilot only – B

□ ISO 80mm pilot only – D

*Torque of non-thru-drive PVM pump, or combined torque of PVM thru-drive pump and thru-driven pump.

NOTE: In those cases where geometric tolerances of mounting are critical, or where specific tolerance ranges are required and not specified, consult Eaton Engineering for specific limits.

Input Shaft Selection Data

SAE Splined Shafts

Model Series	Shaft Designation	Shaft Code	Max. Input Torque† Nm (lb. in.)	Max. Thru-drive Output Torque‡ Nm (lb. in.)
PVM018/020	SAE J744-16-4 (SAE "A," 9T)	03	58 (513)	Exceeds maximum input torque
	SAE J744-19-4 (SAE "A," 11T)	04	123 (1100)	Exceeds maximum input torque
	SAE J744-22-4 (SAE "B," 13T)	07	208 (1850)	123 (1100)
	SAE J744-25-4 (SAE "B-B," 15T)	08	337 (2987)	123 (1100)
PVM045/050	SAE J744-22-4 (SAE "B," 13T)	07	208 (1850)	208 (1850)*
	SAE J744-25-4 (SAE "B-B," 15T)	08	337 (2987)	337 (2987)
PVM057/063	SAE J744-22-4 (SAE "B," 13T)	07	208 (1850)	208 (1850)*
	SAE J744-25-4 (SAE "B-B," 15T)	08	337 (2987)	337 (2987)
	SAE J744-32-4 (SAE "C," 14T)	11	640 (5660)	337 (2987)
PVM074/081	SAE J744-32-4 (SAE "C," 14T)	11	640 (5660)	515 (4560)
PVM098/106	SAE J744-38-4 (SAE "C-C," 17T)	12	1215 (10,750)	515 (4560)
PVM131/141	SAE J744-32-4 (SAE "C," 14T)	11	640 (5660)	640 (5660)
	SAE J744-38-4 (SAE "C-C," 17T)	12	1215 (10,750)	640 (5660)
	SAE J744-44-4 (SAE "D," 13T)	14	1215 (10,750)	640 (5660)

SAE Keyed Shafts

Model Series	Shaft Designation	Shaft Code	Max. Input Torque† Nm (lb. in.)	Max. Thru-drive Output Torque‡ Nm (lb. in.)
PVM018/020	SAE J744-16-1 (SAE "A")	01	58 (513)	Exceeds maximum input torque
	SAE J744-19-1 (SAE "19-1")	02	104 (920)	Exceeds maximum input torque
	SAE J744-22-1 (SAE "B")	05	135 (1200)	123 (1100)
	SAE J744-25-1 (SAE "B-B")	06	215 (1900)	123 (1100)
PVM045/050	SAE J744-22-1 (SAE "B")	05	135 (1200)	135 (1200)*
	SAE J744-25-1 (SAE "B-B")	06	215 (1900)	215 (1900)*
PVM057/063	SAE J744-25-1 (SAE "B-B")	06	215 (1900)	215 (1900)*
	SAE J744-32-1 (SAE "C")	09	450 (3980)	337 (2987)
PVM074/081	SAE J744-32-1 (SAE "C")	09	450 (3980)	450 (3980)*
PVM098/106	SAE J744-38-1 (SAE "C-C")	10	765 (6770)	515 (4560)
PVM131/141	SAE J744-32-1 (SAE "C")	09	450 (3980)	450 (3980)*
	SAE J744-38-1 (SAE "C-C")	10	765 (6770)	640 (5660)
	SAE J744-44-1 (SAE "D")	13	1200 (10,620)	640 (5660)

ISO Keyed Shafts

Model Series	Shaft Designation	Shaft Code	Max. Input Torque† Nm (lb. in.)	Max. Thru-drive Output Torque‡ Nm (lb. in.)
PVM018/020	ISO 3019/2 E20N (B mount only)	15	113 (1000)	Exceeds maximum input torque
	ISO 3019/2 E25N (B mount only)	16	215 (1900)	Exceeds maximum input torque
	ISO 3019/2 E25N (D mount only)	17	215 (1900)	123 (1100)
PVM045/050	ISO 3019/2 E25N	17	215 (1900)	215 (1900)*
PVM057/063	ISO 3019/2 E25N	17	215 (1900)	215 (1900)*
	ISO 3019/2 E32N	18	450 (3980)	337 (2987)
PVM074/081	ISO 3019/2 E32N	18	450 (3980)	450 (3980)*
PVM098/106	ISO 3019/2 E40N	19	870 (7700)	515 (4560)
PVM131/141	ISO 3019/2 E32N	18	450 (3980)	450 (3980)*
	ISO 3019/2 E40N	19	870 (7700)	640 (5660)

†Maximum total torque of the thru-drive pump and the thru-driven pump(s).

‡Maximum torque that can be applied to the thru-driven pump(s).

*This value is limited by the maximum input torque.

Port Options Inlet and Outlet Ports

Model Series	Inlet/Outlet Port Option (per model code, page 5)	Port Code	Inlet Port "B"	Outlet Port "C"
PVM018/020	Inch Flange	02	SAE J518 Code 61, standard pressure. 1.25 inch diameter, .4375-14 x 1.12 bolt holes	SAE J518 Code 61, standard pressure. 0.75 inches diameter, .375-16 x .88 bolt holes
	Metric Flange	04	ISO 6162 Type II, 315 bar. 31,75mm diameter, M10 x 28 bolt holes	ISO 6162 Type II, 315 bar. 19,05mm diameter, M10 x 22 bolt holes
	Inch Tube	01	SAE J514 O-ring -20, for 1-1/4 inch O.D. tube	SAE J514 O-ring -12, for 3/4 inch O.D. tube
	Metric Tube	03	ISO 6149-1, M42 thread	ISO 6149-1, M27 thread
	British Parallel Pipe	05	ISO 228-1:1994 (E), G 1-1/4 thread	ISO 228-1:1994 (E), G 3/4 thread
PVM045/050	Inch Flange	02	SAE J518 Code 61, standard pressure. 2.00 inch diameter, .500-13 x 1.06 bolt holes	SAE J518 Code 61, standard pressure. 1.00 inch diameter, .375-16 x .87 bolt holes
	Metric Flange	04	ISO 6162 Type II, 315 bar. 51mm diameter, M12 x 27 bolt holes	ISO 6162 Type II, 315 bar. 25mm diameter, M10 x 22 bolt holes
	Inch Tube	01	SAE J514 O-ring -24, for 1-1/2 inch O.D. tube	SAE J514 O-ring -16, for 1 inch O.D. tube
	Metric Tube	03	ISO 6149-1, M48 thread	ISO 6149-1, M33 thread
	British Parallel Pipe	05	ISO 228-1:1994 (E), G 1-1/2 thread	ISO 228-1:1994 (E), G1 thread
PVM057/063	Inch Flange	02	SAE J518 Code 61, standard pressure. 2.00 inch diameter, .500-13 x 1.06 bolt holes	SAE J518 Code 61, standard pressure. 1.00 inch diameter, .375-16 x .88 bolt holes
	Metric Flange	04	ISO 6162 Type II, 350 bar. 51mm diameter, M12 x 29 bolt holes	ISO 6162 Type, 350 bar. 25mm diameter, M10 x 23 bolt holes
	Inch Tube (End ported models only)	01	SAE J514 O-ring -24, for 1-1/2 inch O.D. tube	SAE J514 O-ring -16 for 1 inch O.D. tube
	Metric Tube (End ported models only)	03	ISO 6149-1, M48 thread	ISO 6149-1, M33 thread
PVM074/081	Inch Flange	02	SAE J518 Code 61, standard pressure. 2.00 inch diameter, .500-13 x 1.19 bolt holes	SAE J518 Code 61, standard pressure. 1.00 inch diameter, .375-16 x .88 bolt holes
	Metric Flange	04	ISO 6162 Type II, 315 bar. 51mm diameter, M12 x 20 bolt holes	ISO 6162 Type, 400 bar. 25mm diameter, M10 x 17 bolt holes
PVM098/106	Inch Flange	02	SAE J518 Code 61, standard pressure. 2.50 inch diameter, .500-13 x 1.19 bolt holes	SAE J518 Code 61, standard pressure. 1.00 inch diameter, .375-16 x .88 bolt holes
	Metric Flange	04	ISO 6162 Type I, 350 bar. 64mm diameter, M12 x 31 bolt holes	ISO 6162 Type I, 350 bar. 25mm diameter, M10 x 23 bolt holes
PVM131/141	Inch Flange	02	SAE J518 Code 61, standard pressure. 2.50 inch diameter, .500-13 x 1.19 bolt holes	SAE J518 Code 62, high pressure. 1.25 inch diameter, .500-13 x 1.00 bolt holes
	Metric Flange	04	ISO 6162 Type II, 315 bar. 64mm diameter, M12 x 31 bolt holes	ISO 6162 Type, 400 bar. 32mm diameter, M12 x 27 bolt holes

Drain, Load Sensing, and Gauge Ports

Model Series	Inlet/Outlet Port Option (per model code, page 5)	Port Code	Drain Port "F"	Load Sensing Port "J"	Gauge Port "K"
PVM018/020	Inch Flange or Tube	01, 03	SAE J514 O-ring, .50" O.D. tube. .750-16 UNF 2B thread	SAE J514 O-ring, .25" O.D. tube. .4375-20 UNF 2B thread	SAE J514 O-ring, .25" tube. .4375-20 UNF 2B thread
	Metric Flange or Tube	03, 04	ISO 6149-1 O-ring M18 x 1,5 thread	ISO 6149-1 O-ring M12 x 1,5 thread	ISO 6149-1 O-ring M12 x 1,5 thread
	British Parallel Pipe	05	ISO 228-1:1994 (E) G 1/2 thread	ISO 228-1:1994 (E) G 1/4 thread	ISO 228-1:1994 (E) G 1/4 thread
PVM045/050	Inch Flange or Tube	01, 03	SAE J514 O-ring, .625" O.D. tube. .875-14 UNF 2B thread	SAE J514 O-ring, .250" O.D. tube. .4375-20 UNF 2B thread	SAE J514 O-ring, .375" O.D. tube. .5625-18 UNF 2B thread
	Metric Flange or Tube	03, 04	ISO 6149-1 O-ring M22 x 1,5 thread	ISO 6149-1 O-ring M12 x 1,5 thread	ISO 6149-1 O-ring M14 x 1,5 thread
	British Parallel Pipe	05	ISO 228-1:1994 (E) G 1/2 thread	ISO 228-1:1994 (E) G 1/4 thread	ISO 228-1:1994 (E) G 1/4 thread
PVM057/063	Inch Flange or Tube	01, 02	SAE J514 O-ring, .625" O.D. tube. .875-14 UNF 2B thread	SAE J514 O-ring, .375" O.D. tube. .5625-18 UNF 2B thread	SAE J514 O-ring, .375" O.D. tube. .5625-18 UNF 2B thread
	Metric Flange or Tube	03, 04	ISO 6149-1 O-ring M22 x 1,5 thread	ISO 6149-1 O-ring M14 x 1,5 thread	ISO 6149-1 O-ring M14 x 1,5 thread
PVM074/83 PVM098/106	Inch Flange	02	SAE J514 O-ring, .625" O.D. tube. .875-14 UNF 2B thread	SAE J514 O-ring, .375" O.D. tube. .562-18 UNF 2B thread	SAE J514 O-ring, .375" O.D. tube. .5625-18 UNF 2B thread
	Metric Flange	04	ISO 6149-1 O-ring M22 x 1,5 thread	ISO 6149-1 O-ring M14 x 1,5 thread	ISO 6149-1 O-ring M14 x 1,5 thread
PVM131/141	Inch Flange	02	SAE J514 O-ring, .625" O.D. tube. .875-14 UNF 2B thread	SAE J514 O-ring, .375" O.D. tube. .562-18 UNF 2B thread	SAE J514 O-ring, .375" O.D. tube. .5625-18 UNF 2B thread
	Metric Flange	04	ISO 6149-1 O-ring M22 x 1,5 thread	ISO 6149-1 O-ring M14 x 1,5 thread	ISO 6149-1 O-ring M14 x 1,5 thread