

■ 特点 Feature:

OMV马达是一种盘配流马达

先进的盘配流设计, 低速性能好 容积效率高, 并具有磨损自动补偿功能

双列圆锥滚针轴承能够承受大的径向力, 并应用于重载驱动场合

OMV motor is one disc valve type gerotor motor,

Advanced design of disc distribution flow, which can provide improved performance at low speed

Higher volumetric for the automatically compensate wear.

Double taper roller bearings permit high radial loads, can be used on heavy vehicles in traction drive applications



■ OMV型号说明 Model Code

OMV	-800	4	P1	D
系列 Code	排量 Displace	安装法兰及止口 Mounting Flange&Spigot	输出轴 Shaft	油口&泄油口 Inlet&Outlet and Drain Port
OMV	315,400,500,630,800,1000	4: 4-φ18方法兰 Square Flange (φ200),止口 Spigot φ160x11 W: 4-φ18车轮法兰 Wheel Flange (φ224),止口 Spigot φ180x10	P1: φ50(82),key14x9x70 P2: φ57.15(82), key12.7x12.7x57.15 H1: φ53.975(82), 16-DP8/16 H2: φ53.975(82), 16-DP8/16 H3: φ45, 17Zx2.5x30Px5e Z1: φ60锥轴 Taper, key B16x10x32 Z2: 57.2锥轴 Taper, key14.308x14.308x50.8	D: G1,G3/4,4-M12 M: M33x2,M14x1.5,4-M12 S: 1-5/16-12UN, 9/16-18UNF G: G1,G1/4 M5: M33x2,M14x1.5 D1: G3/4,G1/4,4-M12
OMVE		K6: 4-φ14.2方形法兰 Square Flange (φ162),止口 Spigot φ127x11 K4: 4-φ14.2方法兰 Square Flange (φ160),止口 Spigot φ125x11	P3: φ40(79),key12x8x70 P4: φ40(56),key12x8x45	

■ OMV技术参数 Technical Data

型号 TYPE	OMV OMVE 315	OMV OMVE 400	OMV OMVE 500	OMV OMVE 630	OMV OMVE 800	OMV OMVE 1000	
排量 Displacement(ml/r)	333	419	518	666	801	990	
最大压降 Max.Pressure.Drop(Mpa) (Mpa)	连续 cont.	20	20	20	18	16	14
	间断 int.	24	24	24	21	18	16
	尖峰 peak.	28	28	28	24	21	18
最大扭矩 Max.Torque(N.m)	连续 cont.	920	1180	1460	1660	1880	2015
	间断 int.	1110	1410	1760	1940	2110	2280
	尖峰 peak.	1290	1640	2050	2210	2470	2400
转速范围 (连续) Speed.Range(cont)(r/min)	510	500	400	320	250	200	
最大流量 (连续) Max Flow(cont)(L/min)	160	200	200	200	200	200	
最大输出功率 (连续) Max.output.Power(cont)(Kw)	38	47	47	40	33	28.6	
重量 Weight(Kg)	31.8	32.6	33.5	34.9	36.5	38.6	

OMV 安装连接尺寸 Dimension

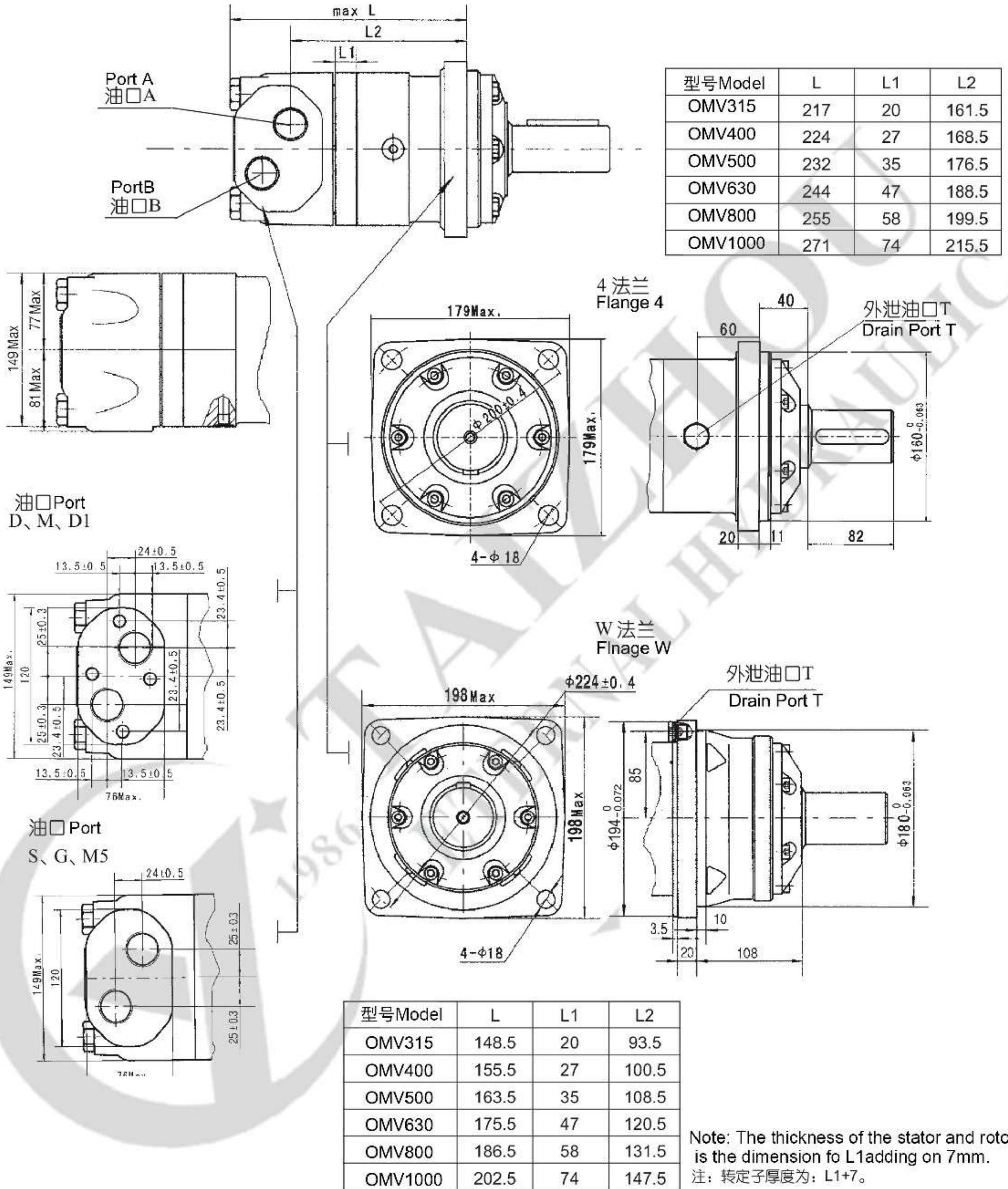

内容 Content	代号 Code					
	D(深)(depeth)	M(深)(depeth)	S(深)(depeth)	G(深)(depeth)	M5(深)(depeth)	D1(深)(depeth)
连接尺寸 Mounting						
P(A,B)	G1 (18)	M33 x 2 (18)	1-5/16-12UN(18)	G1 (18)	M33 x 2 (18)	G3/4(18)
T	G1/4 (12)	M14 x 1.5 (12)	9/16-18UNF(12)	G1/4 (12)	M14 x 1.5 (12)	G1/4 (12)
C	4-M12 (12)	4-M12 (12)	--	--	--	4-M12 (12)

■ OMVE 安装连接尺寸 Dimension

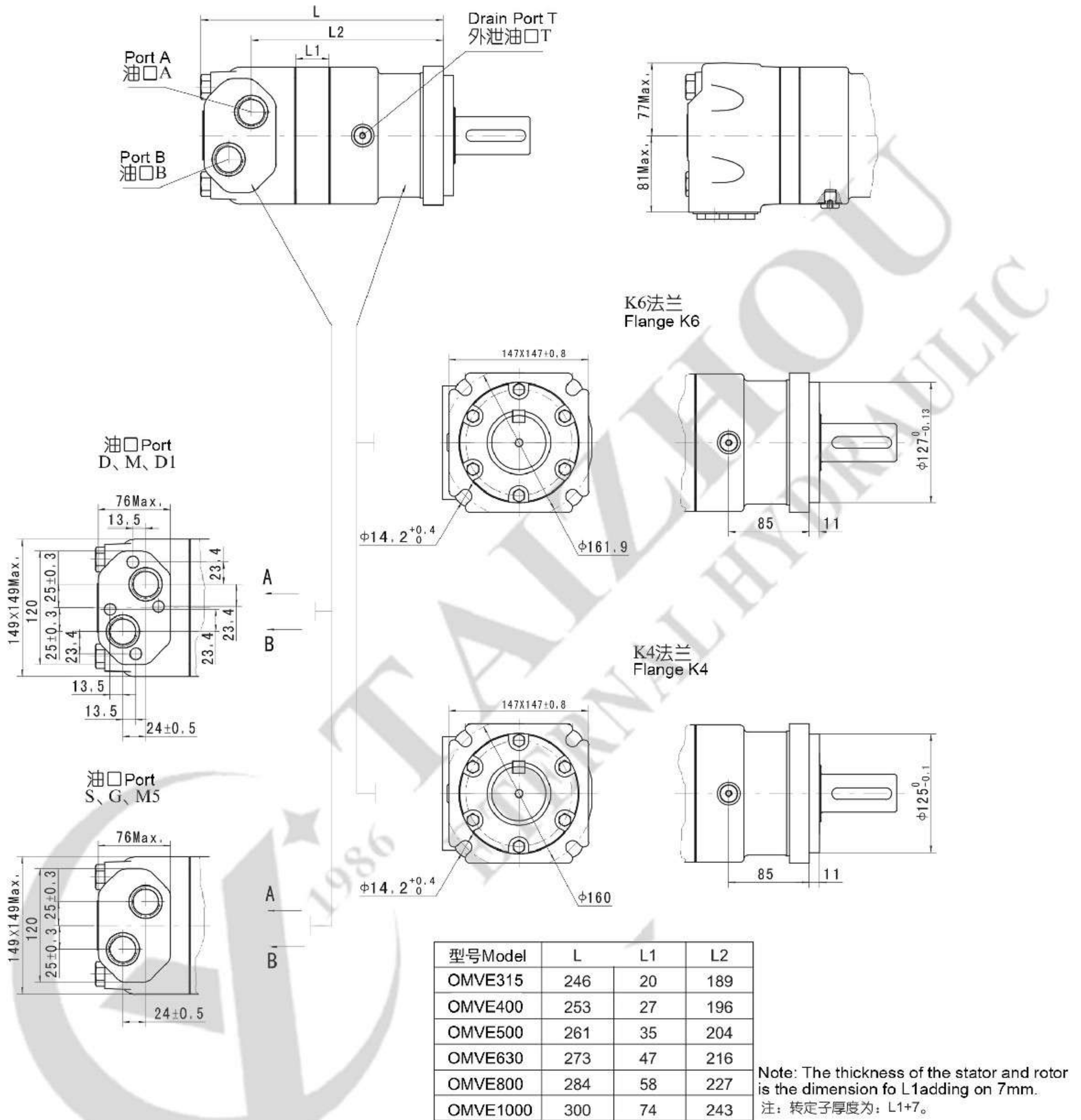

内容 Content 连接尺寸 Mounting	代号Code					
	D(深)(depeth)	M(深)(depeth)	S(深)(depeth)	G(深)(depeth)	M5(深)(depeth)	D1(深)(depeth)
P(A,B)	G1 (18)	M33 x 2 (18)	1-5/16-12UN(18)	G1 (18)	M33 x 2 (18)	G3/4(18)
T	G1/4 (12)	M14 x 1.5 (12)	9/16-18UNF(12)	G1/4 (12)	M14 x 1.5 (12)	G1/4(12)
C	4-M12 (12)	4-M12 (12)	--	--	--	4xM12(12)

