

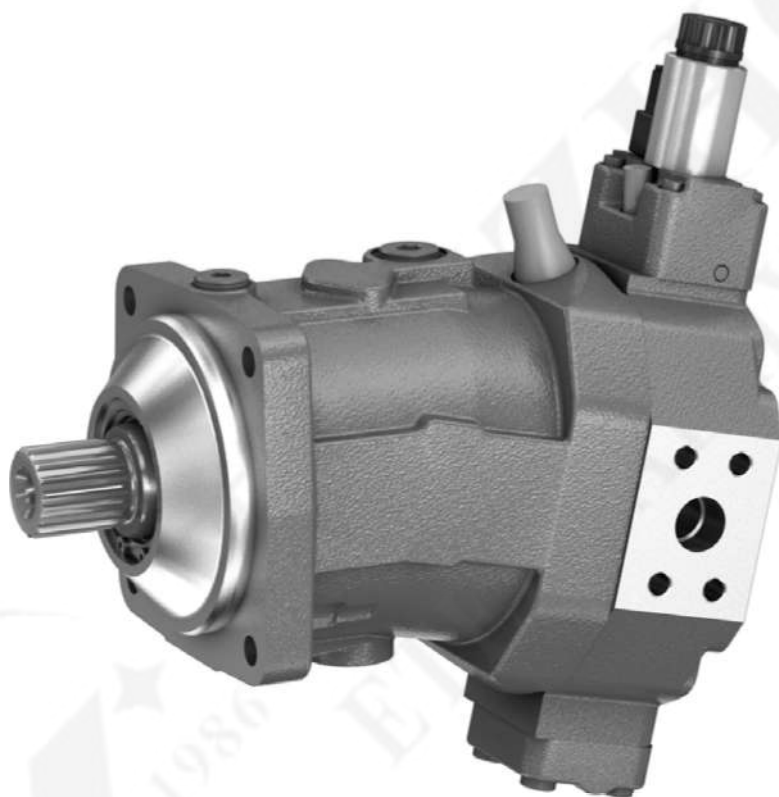

Axial piston variable motor A6VM

Series 65 and 71

台州永暢液壓機械有限公司
Taizhou Eternal Hydraulic Machine Co.,Ltd.



Contents

1	About this documentation	5
1.1	Validity of the documentation	5
1.2	Required and supplementary documentation	5
1.3	Display of information	6
1.3.1	Safety instructions	6
1.3.2	Symbols	7
1.3.3	Designations	7
1.3.4	Abbreviations	7
2	Safety instructions	8
2.1	About this chapter	8
2.2	Intended use	8
2.3	Improper use	8
2.4	Personnel qualifications	9
2.5	General safety instructions	9
2.6	Product-specific safety instructions	10
2.7	Personal protective equipment	13
3	General instructions on damage to property and the product	14
4	Scope of delivery	17
5	About this product	18
5.1	Performance description	18
5.2	Product description	18
5.2.1	Layout of the axial piston unit	18
5.2.2	Functional description	19
5.3	Product identification	20
6	Transport and storage	21
6.1	Transporting the axial piston unit	21
6.1.1	Transporting by hand	21
6.1.2	Transporting with lifting device	21
6.2	Storing the axial piston unit	23
7	Installation	25
7.1	Unpacking	25
7.2	Installation conditions	25
7.3	Installation position	27
7.3.1	Below-reservoir installation (standard)	27
7.3.2	Above-reservoir installation	28
7.4	Installing the axial piston unit	29
7.4.1	Preparation	29
7.4.2	Dimensions	29
7.4.3	General notes	29
7.4.4	Installation with coupling	31
7.4.5	Installation on a gearbox	32
7.4.6	Installation with cardan shaft	32
7.4.7	Completing installation	32
7.4.8	Hydraulically connecting the axial piston unit	33
7.4.9	Electrically connecting the axial piston unit	40
7.5	Performing flushing cycle	41

8	Commissioning	42
8.1	Initial commissioning	42
8.1.1	Filling the axial piston unit	42
8.1.2	Testing the hydraulic fluid supply	44
8.1.3	Performing functional test	44
8.2	Running-in phase	45
8.3	Recommissioning after standstill	45
9	Operation	46
10	Maintenance and repair	47
10.1	Cleaning and care	47
10.2	Inspection	47
10.3	Maintenance	48
10.4	Repair	48
10.5	Spare parts	49
11	Removal and replacement	50
11.1	Required tools	50
11.2	Preparing for removal	50
11.3	Carrying out removal	50
11.4	Preparing the components for storage or further use	50
12	Disposal	51
13	Extension and conversion	51
14	Troubleshooting	52
14.1	How to proceed with troubleshooting	52
14.2	Malfunction table	53
15	Technical data	55
16	Alphabetical index	56

1 About this documentation

1.1 Validity of the documentation

This documentation is valid for the following product:

- Axial piston variable motor A6VM series 65
- Axial piston variable motor A6VM series 71

This documentation is intended for machine/system manufacturers, fitters and service technicians.

This documentation contains important information on the safe and appropriate transport, installation, commissioning, operation, maintenance, removal and simple troubleshooting of the axial piston unit.

- ▶ Read this documentation completely and in particular the chapter 2 “Safety instructions” on page 8 and chapter 3 “General instructions on damage to property and the product” on page 14 before you start work with the axial piston unit.

1.2 Required and supplementary documentation









- ▶ Only commission the axial piston unit if the documentation marked with the book symbol  is available to you and you have understood and observed it.

Table 1: Required and supplementary documentation

Title	Document number	Document type
 Order confirmation Contains the order-related technical data for your A6VM axial piston variable motor.	-	Order confirmation
 Installation drawing Contains the outer dimensions, all connections and the hydraulic circuit diagram for your axial piston variable motor A6VM.	Please request the installation drawing via your contact person	Installation drawing
 Axial piston variable motor A6VM series 65 Axial piston variable motor A6VM series 71 Contains the permissible technical data.	91607 91610	Data sheet
 Mineral-oil based hydraulic fluids and related hydrocarbons Describes the requirements for a mineral-oil based hydraulic fluid and related hydrocarbons for operation hydraulic components, and assists you in selecting a hydraulic fluid for your hydraulic system.	90220	Data sheet
 Environmentally acceptable hydraulic fluids Describes the requirements on an environmentally acceptable hydraulic fluid for operation components and assists you in selecting a hydraulic fluid for your hydraulic system.	90221	Data sheet
 Fire-resistant, water-free hydraulic fluids (HF DU/HFDR) Describes the requirements on fire-resistant, water-free hydraulic fluids for operation components and assists you in selecting a hydraulic fluid for your hydraulic system.	90222	Data sheet
 Axial piston units for operation with HF hydraulic fluids Contains additional information on the use of axial piston units with HF hydraulic fluids.	90223	Data sheet
Information for the use of hydrostatic drives at low temperatures Contains additional information on the use of axial piston units at low temperatures.	90300-03-B	Manual
Storage and preservation of axial piston units Contains additional information on storage and preservation.	90312	Data sheet

1.3 Display of information

Standardized safety instructions, symbols, terms and abbreviations are used throughout this documentation so that you can work quickly and safely with your product. To give you a better understanding, these are explained in the sections below.

1.3.1 Safety instructions



This manual includes safety instructions in chapter 2.6 “Product-specific safety instructions” on page 10 and in chapter 3 “General instructions on damage to property and the product” on page 14 and before a sequence of actions or an instruction involving a risk of personal injury or damage to equipment. The measures described to avert danger must be observed.

Safety instructions are set out as follows:

 SIGNAL WORD
Type and source of danger Consequences of non-compliance ▶ Measures to avert danger

- **Warning sign:** draws attention to the danger
- **Signal word:** identifies the degree of danger
- **Type and source of the danger:** identifies the type and source of the danger
- **Consequences:** describes what will happen if the safety instructions are not complied with
- **Precautions:** states how the danger can be avoided

Table 2: Hazard classes as defined in ANSI Z535.6-2006

Warning sign, signal word	Meaning
 DANGER	Identifies a dangerous situation that will result in death or serious injuries if it is not avoided.
 WARNING	Identifies a dangerous situation that may result in death or serious injuries if it is not avoided.
 CAUTION	Identifies a dangerous situation that may result in minor to moderate injuries if it is not avoided.
NOTICE	Property damage: The product or the environment may be damaged.

1.3.2 Symbols

The following symbols indicate information that is not directly relevant to safety but increases understanding of the manual.

Table 3: Meaning of the symbols

Symbol	Meaning
	If this information is disregarded, the product cannot be used or operated to its optimum potential.
▶	Single, independent step
1.	Numbered instruction:
2.	The numbers indicate that the steps must be completed one after the other.
3.	

1.3.3 Designations

This documentation uses the following designations:

Table 4: Designations

Designation	Meaning
A6VM	Axial piston variable motor, open and closed circuits
Threaded plug	Metal screw, pressure-resistant
Protective plug	Made out of plastic, not pressure-resistant, only for transportation

As a generic term for the “A6VM axial piston variable motor” the designation “axial piston unit” is used in the following.

1.3.4 Abbreviations

This manual uses the following abbreviations:

Table 5: Abbreviations

Abbreviation	Meaning
ATEX	EU directive on explosion protection (A tmosphère e xplosible)
DIN	D eutsche I ndustrie N orm (German Institute for Standardization)
EP	P roportional control e lectric
EZ	T wo point control e lectric
HA	A utomatic control, h igh-pressure related
HP	P roportional control h ydraulic
HZ	T wo-point control, h ydraulic
ISO	I nternational O rganization for S tandardization (Internationale Normierungsorganisation)
JIS	J apan I ndustrial S tandard
RE	Document in the E nglish language
VDI 2230	Directive for the systematic calculation of high duty bolted joints and joints with one cylindrical bolt from the VDI (V erein D eutscher I ngenieure - A ssociation of German Engineers)

2 Safety instructions

2.1 About this chapter

The axial piston unit has been manufactured according to the generally accepted rules of current technology. There is, however, still a danger of personal injury or damage to equipment if this chapter and the safety instructions in this documentation are not complied with.

- ▶ Read this documentation completely and thoroughly before working with the axial piston unit.
- ▶ Keep this documentation in a location where it is accessible to all users at all times.
- ▶ Always include the required documentation when you pass the axial piston unit on to third parties.

2.2 Intended use

Axial piston units are hydraulic components, meaning that in their application they are classified neither as complete nor as incomplete machines in the sense of the EU machine directive 2006/42/EC. A component is exclusively intended to form an incomplete or a complete machine together with other components. The component may only be commissioned after it has been installed in the machine/system for which it is intended and the safety of the entire system has been established in accordance with the machine directive.

The product is intended for the following use:

The axial piston unit is only approved as a hydraulic motor in hydrostatic drive systems.

- ▶ Observe the technical data, application and operating conditions and performance limits as specified in data sheet 91607 and 91610 and in the order confirmation. Information about approved hydraulic fluids can be found in data sheet 91607 and 91610.

The axial piston unit is only intended for professional use and not for private use. Intended use also includes having read and understood the documentation in full, especially the chapter 2 “Safety instructions” on page 8.

2.3 Improper use

Any use other than that described as intended use shall be considered as improper and is therefore impermissible.

shall accept no liability whatsoever for damages resulting from improper use. The user shall bear all risks arising from improper use.

The following foreseeable forms of misuse shall also be considered to be improper (this list does not claim to be exhaustive):

- Use outside the operating parameters approved in the data sheet or in the order confirmation (unless customer-specific approval has been granted and confirmed in writing)
- Use of non-approved fluids, e.g. water or polyurethane components
- Modification of the factory settings by non-authorized personnel
- Use of add-on parts (e.g. control unit, valves) not in combination with specified components

- Using the axial piston unit under water at a depth of more than 10 meters without necessary additional measures, e.g., pressure equalization
- Using the axial piston unit when the ambient pressure is greater than the interior pressure (case pressure)
- Using the axial piston unit in explosive environments unless the component or machine/system has been certified as compliant with the ATEX directive 94/9/EC
- Use of the axial piston unit in an aggressive atmosphere
- Use of the axial piston unit in aircraft or space craft

2.4 Personnel qualifications

The activities described in this documentation require basic mechanical, electrical and hydraulics expertise, as well as knowledge of the associated technical terms. For transporting and handling the product, additional knowledge is necessary with regard to working with lifting gear and the corresponding attachment equipment. In order to ensure safe use, these activities may therefore only be performed by an appropriately qualified person or an instructed person under the direction and supervision of a qualified person.

Qualified personnel are those who can recognize possible hazards and institute the appropriate safety measures due to their professional training, knowledge, and experience, as well as their understanding of the relevant conditions pertaining to the work to be done. Qualified personnel must observe the rules relevant to the specialist field and have the necessary hydraulics expertise.

Hydraulic expertise includes:

- Reading and fully understanding hydraulic diagrams,
- Specifically, fully understanding the relationships with regard to safety devices, and
- Understanding how hydraulic components work and are put together



Offers training support for specialist fields. An overview of the training contents can be found on the Internet at:

www.boschrexroth.com/training.

2.5 General safety instructions

- Observe the applicable accident prevention and environmental protection regulations.
- Observe the safety regulations and provisions of the country in which the product is used/operated.
- Use products only when they are in good technical order and condition.
- Observe all notes on the product.
- Persons who install, operate, remove or maintain products must not consume any alcohol, drugs or pharmaceuticals that may affect their ability to respond.
- Only use genuine accessories and spare parts to ensure there is no risk to personnel from unsuitable spare parts.
- Adhere to the technical data and ambient conditions specified in the product documentation.

- If unsuitable products are installed or used in applications that are relevant for safety, unexpected operating conditions may occur in the application, which could result in injury to personnel or damage to equipment. For this reason, only use the product in a safety-related application if this use is expressly specified and permitted in the product documentation, for example in explosion protection applications or in safety-related parts of a control system (functional safety).
- You may only commission the product if it has been determined that the end product (e.g., machinery or system) in which the products are installed complies with the country-specific provisions, safety regulations and standards for the application.

2.6 Product-specific safety instructions

The following safety instructions apply for chapters 6 to 14.

WARNING

Danger from excessively high pressure!

Danger to life or risk of injury, damage to equipment.

An inappropriate change in the factory pressure settings can result in a pressure increase beyond the permissible maximum pressure.

Operating the unit above the permissible maximum pressure can cause components to burst and hydraulic fluid to escape under high pressure.

- ▶ Changes to the factory settings must only be made specialist personnel.
- ▶ In addition, a pressure relief valve is needed as back-up in the hydraulic system. If the axial piston unit is equipped with a pressure cut-off and/or a pressure control, this is not an adequate back-up against pressure overload.

Danger from suspended loads!

Danger to life or risk of injury, damage to equipment.

Improper transportation may cause the axial piston unit to fall down and lead to injuries e.g. crushing or broken bones or damage to the product.

- ▶ Make sure that the load capacity of the lifting gear is sufficient to safely bear the weight of the axial piston unit.
- ▶ Never step or reach under a suspended load.
- ▶ Ensure a stable position during transportation.
- ▶ Use your personal protective equipment (e.g., safety glasses, safety gloves, suitable working clothes, safety shoes).
- ▶ Use suitable lifting gear for transportation.
- ▶ Observe the prescribed position of the lifting strap.
- ▶ Observe the national laws and regulations on work and health protection and transportation.

WARNING

Pressurized machine/system!

Danger to life or risk of injury, serious injuries when working on machines/systems not shut down. Damage to equipment.

- ▶ Switch off the entire system and secure it against reconnection according to information provided by the machine/system manufacturer.
- ▶ Make sure that all relevant components of the hydraulic system are depressurized. Follow the machine/system manufacturer's specifications.
- ▶ Note that the hydraulic system may still be under pressure even after the separation of the actual pressure supply.
- ▶ Do not disconnect any line connections, ports and components while the hydraulic system is pressurized.

Escaping oil mist!

Risk of explosion, fire, health hazard, environmental pollution.

- ▶ Depressurize the machine/system and repair the leak.
- ▶ Only perform welding work when the machine/system is depressurized.
- ▶ Keep open flames and ignition sources away from the axial piston unit.
- ▶ If axial piston units are to be situated in the vicinity of ignition sources or powerful thermal radiators, a shield must be erected to ensure that any escaped hydraulic fluid can not ignite, and to protect hose lines from premature aging.

Electrical voltage!

Risk of injury due to electric shock or damage to equipment.

- ▶ Always set up the relevant part of the machine/system so that it is free of electrical voltage before you install the product or when connecting and disconnecting plugs. Protect the machine/system against being energized.

Overloading of the axial piston motor!

Risk of injury or damage to equipment!

When using the axial piston motor in winch drives it can, when extremely overloaded (e.g. if the maximum permissible rotational speeds are exceeded during weighing of the anchor while the ship is in motion) cause damage to the rotary group and in the worst case, the axial piston motor may burst.

- ▶ Ensure that the technical limits are not exceeded in any operating conditions.
- ▶ Check whether any additional measures are needed for your machine/system (up to an encapsulation) in order to avoid injury to persons. If necessary, make sure that these are properly implemented.
- ▶ For safety reasons, axial piston variable motors with beginning of control at $V_{g \min}$ (e.g., HA) are not permissible for winch drives (e.g. anchor winches).

 **WARNING**

Limitation of the control function!

Risk of injury or damage to equipment!

Moving parts in control equipment (e.g. valve pistons) can, under certain circumstances get blocked in position as a result of contamination (e.g. impure hydraulic fluid, abrasion, or residual dirt from components). As a result, the flow of hydraulic fluid and the build-up of momentum in the axial piston unit can no longer meet the operator's specifications. Even the use of various filter elements (external or internal flow filtering) cannot rule out errors, but can only help minimize risks.

- ▶ Check whether remedial measures for your application are needed on your machine in order to put the driven consumer in a safe state (e.g. safe stop).
- ▶ If necessary, make sure that these are properly implemented.

CAUTION

High noise levels during operation!

Danger of hearing damage, deafness.

The noise emission of axial piston units depends on, among other factors, rotational speed, operating pressure and installation conditions. The sound pressure level may rise above 70 dB (A) during normal application conditions.

- ▶ Always wear hearing protection when in the vicinity of the operating axial piston unit.

Hot surfaces on the axial piston unit!

Risk of burns!

- ▶ Allow the axial piston unit to cool down sufficiently before touching it.
- ▶ Wear heat-resistant protective clothing, e.g. gloves.

Improper routing of cables and lines!

Tripping danger and damage to equipment!

- ▶ Lay cables and lines so that they can not be damaged and nobody can trip over them.

Contact with hydraulic fluid!

Health hazard / risk of health impairment, e.g., eye injuries, skin damage, poisoning on inhalation.

- ▶ Avoid contact with hydraulic fluids.
- ▶ When working with hydraulic fluids, strictly observe the safety instructions provided by the lubricant manufacturer.
- ▶ Use your personal protective equipment (e.g., safety glasses, safety gloves, suitable working clothes, safety shoes).
- ▶ If hydraulic fluid should, nevertheless, come into contact with your eyes, get into your bloodstream or be swallowed, consult a doctor immediately.

Escaping hydraulic fluid due to machine/system leakage!

Risk of burns and risk of injury due to escaping oil jet.

- ▶ Depressurize the machine/system and repair the leak.
- ▶ Never attempt to block or seal the leak or oil jet with a cloth.

2.7 Personal protective equipment

The personal protective equipment is the responsibility of the user of the axial piston unit. Observe the safety regulations and provisions in your country.

All components of the personal protective equipment must be intact.

3 General instructions on damage to property and the product

The following instructions apply for chapters 6 to 14.

NOTICE

Danger from improper handling.

Product can be damaged!

- ▶ Do not expose the product to a non-permitted mechanical load.
- ▶ Never use the product as a handle or step.
- ▶ Do not place/lay any objects on the product.
- ▶ Do not strike the drive shaft of the axial piston unit.
- ▶ Do not set/place the axial piston unit on the drive shaft or fittings.
- ▶ Do not strike fittings (e.g., sensors or valves).
- ▶ Do not strike sealing surfaces (e.g. working line ports).
- ▶ Leave the protective covers on the axial piston unit until shortly before the lines are connected.
- ▶ Disconnect all electrical connectors before performing electro-welding or painting operations.
- ▶ Make certain that the electronic components (e.g., sensors) do not become electrostatically charged (e.g., during painting operations).

Damage to equipment due to improper lubrication!

Product can be damaged or destroyed.

- ▶ Never operate the axial piston unit with insufficient hydraulic fluid. In particular, make sure that the rotary group has sufficient lubrication.
- ▶ When commissioning a machine/system, make sure that the case interior and the working lines of the axial piston unit are filled with hydraulic fluid and remain filled during operation. Air inclusions in the forward drive shaft bearing are to be prevented, especially with the installation position “drive shaft upwards”.
- ▶ With the installation position “drive shaft upwards” additional air bleeding is to be provided via the flushing port **U**.
- ▶ Check the hydraulic fluid level in the motor housing regularly; if necessary, recommission. With above-reservoir installation, the motor housing may drain via the drain line after longer standstill periods (air enters via the shaft seal) or via the working line (gap leakage). When switched on, the bearings are thus insufficiently lubricated.

Mixing of hydraulic fluids.

Product can be damaged!

- ▶ Before installation, remove all fluids from the axial piston unit to prevent mixing with the hydraulic fluid used in the machine/system.
- ▶ Any mixing of hydraulic fluids from different manufacturers or different types from the same manufacturer is not generally permitted.

NOTICE

Contamination of the hydraulic fluid!

The cleanliness of the hydraulic fluid has a considerable impact on the cleanliness and service life of the hydraulic system. Contamination of the hydraulic fluid could cause premature wear and malfunctions.

- ▶ Make sure that the working environment at the installation site is fully free of dust and foreign substances in order to prevent foreign particles, such as welding beads or metal cuttings, from getting into the hydraulic lines and causing product wear or malfunctions. The axial piston unit must be installed in a clean condition.
- ▶ Use only clean connections, hydraulic lines and attachments (e.g. measuring equipment).
- ▶ No contaminants may enter the ports when they are sealed.
- ▶ Before commissioning, make sure that all hydraulic connections are tight and that all of the connection seals and plugs are installed correctly to ensure that they are leak proof and fluids and contaminants are prevented from penetrating the product.
- ▶ Use a suitable filter system to filter hydraulic fluid during filling to minimize solid impurities and water in the hydraulic system.

Improper cleaning!

Product can be damaged.

- ▶ Plug all openings with the appropriate protection equipment in order to prevent cleaning agents from entering the hydraulic system.
- ▶ Never use solvents or aggressive cleaning agents. Use only water and, if necessary, a mild cleaning agent to clean the axial piston unit.
- ▶ Do not point the high-pressure cleaner at sensitive components, e.g., shaft seal, electrical connections and components.
- ▶ Use lint-free cloths for cleaning.

Environmental pollution due to incorrect disposal!

Careless disposal of the axial piston unit and its fittings, the hydraulic fluid and the packaging material can lead to pollution of the environment!

- ▶ Dispose of the axial piston unit, hydraulic fluid and packaging in accordance with the national regulations in your country.
- ▶ Dispose of the hydraulic fluid in accordance with the applicable safety data sheet for the hydraulic fluid.

Escaping or spilling hydraulic fluid!

Environmental pollution and contamination of groundwater.

- ▶ Always place a drip tray under the axial piston unit when filling and draining the hydraulic fluid.
- ▶ Use an oil binding agent if hydraulic fluid is spilt.
- ▶ Observe the information in the safety data sheet for the hydraulic fluid and the specifications provided by the system manufacturer.

The warranty only applies to the delivered configuration.
The warranty entitlement is rendered void if the product is incorrectly installed,
commissioned or operated, as well as in cases of improper use and/or handling.

4 Scope of delivery

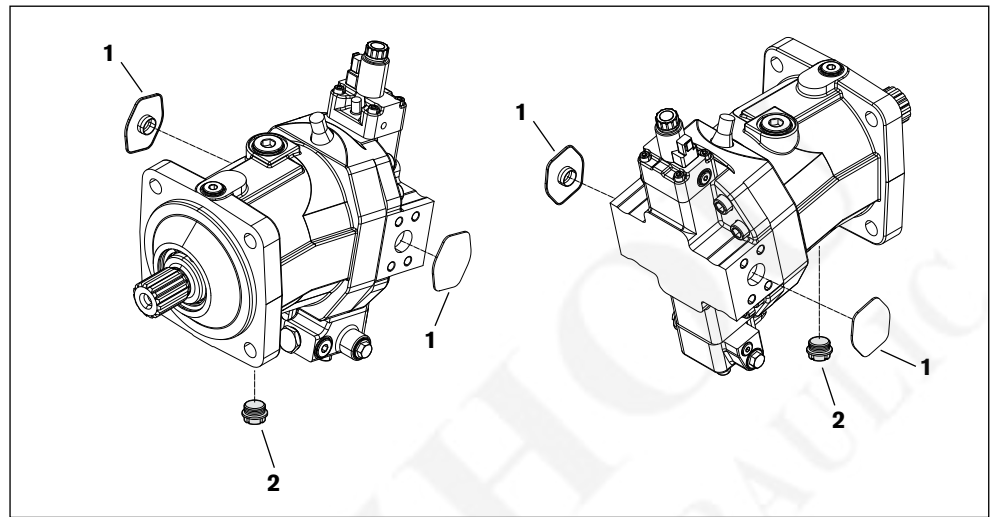

Fig. 1: Axial piston unit

Included in the scope of delivery are:

- Axial piston unit as per order confirmation

The following parts are also fitted prior to delivery:

- Protective covers (1)
- Protective plug/threaded plug (2)

5 About this product

5.1 Performance description

A Axial piston variable motor converts hydrostatic flow into mechanical rotation and controls or regulates this. The A6VM is designed for mobile and stationary applications.

Refer to data sheets 91607 and 91610 and to the order confirmation for the technical data, operating conditions and operating limits of the axial piston unit.

5.2 Product description

The A6VM is a variable motor with axial piston rotary group of bent-axis design, for hydrostatic drives in open and closed circuits. For axial piston units with bent-axis design, the pistons (**7**) are arranged at an angle to the drive shaft (**1**). The pistons rest directly on the drive shaft where they generate torque depending on the pressure and swivel angle. The specific torque and displacement can be changed by adjusting the bent axis.

Open circuit In the open circuit, the hydraulic fluid flows from the reservoir to the hydraulic pump from where it is transported to the hydraulic motor. From the hydraulic motor, the hydraulic fluid flows directly back to the reservoir. The output direction of rotation of the hydraulic motor can be changed, e.g. by a directional valve.

Closed circuit In the closed circuit, the hydraulic fluid flows from the hydraulic pump to the hydraulic motor and from there directly back to the hydraulic pump. The output direction of rotation of the hydraulic motor is changed, e.g. by reversing the flow direction in the hydraulic pump.

5.2.1 Layout of the axial piston unit

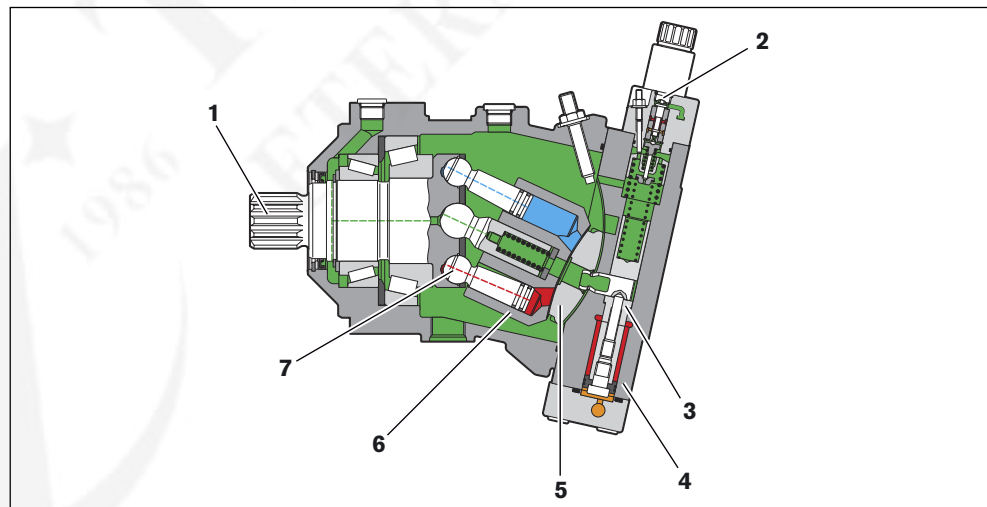

Fig. 2: Layout of the A6VM

- | | | |
|-------------------------|---------------------|-----------------|
| 1 Drive shaft | 4 Port plate | 7 Piston |
| 2 Control piston | 5 Lens plate | |
| 3 Stroke piston | 6 Cylinder | |

5.2.2 Functional description

- Motor function** A hydraulic motor converts hydrostatic energy into mechanical energy. Hydraulic fluid is directed via the port plate (4) and the lens plate (5) to the cylinder bores. The pistons (7) in the cylinder bores execute a stroke that is converted into rotary movement by the piston on the drive shaft flange. During this process, the pistons move the cylinder (6) and generate an output torque at the drive shaft. The output torque increases with the pressure difference between the high- and low-pressure sides and increasing displacement. The output speed is proportional to the inward flow and inversely proportional to the displacement of the hydraulic motor.
- Flushing and boost pressure valve (optional)** The flushing and boost pressure valve is used to remove heat from the hydraulic circuit. In an open circuit, it is used exclusively for flushing the case. In a closed circuit, it ensures a minimum boost pressure level in addition to the case flushing. Hydraulic fluid is directed from the respective low pressure side into the motor case. This is then fed into the reservoir, together with the case drain fluid. The hydraulic fluid removed from the closed circuit must be replaced by cooled hydraulic fluid from the boost pump.
- Control** The swivel angle of the bent-axis rotary group is steplessly variable. With two-point control (HZ, EZ), the swivel angle can be switched from maximum to minimum angle. Control of the swivel angle of the bent-axis rotary group changes the piston stroke and therefore the displacement. The swivel angle is changed hydraulically via the stroke piston (3). Here, the cylinder is swiveled including the pistons and lens plate. The lens plate is mounted for easy motion in a guideway. Increasing the swivel angle results in an increase in the displacement and specific torque; decreasing the swivel angle results in a corresponding decrease of these values. The output speed is dependent on the input flow and the displacement of the hydraulic motor.



Various control devices are available depending on requirements. Information about this can be found in data sheet 91607 and 91610.

5.3 Product identification

The axial piston unit can be identified from the name plate. The following example shows an A6VM name plate:

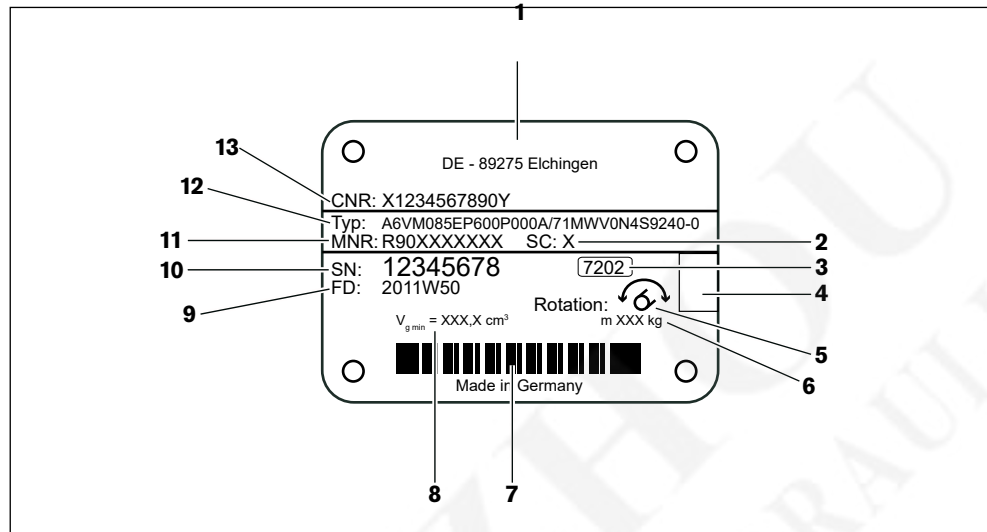

Fig. 3: Name plate A6VM

- | | |
|--|--|
| 1 Manufacturer | 8 Minimum displacement |
| 2 Sample category (optional) | 9 Production date |
| 3 Internal plant designation | 10 Serial number |
| 4 Specified area for test stamp | 11 Material number of the axial piston unit |
| 5 Direction of rotation (looking at drive shaft) – here: bi-directional | 12 Ordering code |
| 6 Weight (optional) | 13 Customer material number |
| 7 Barcode | |

6 Transport and storage

- ▶ Always observe the required ambient conditions for transport and storage, see chapter 6.2 “Storing the axial piston unit” on page 23.



Notes on unpacking can be found in chapter 7.1 “Unpacking” on page 25.

6.1 Transporting the axial piston unit

The following transportation options are available depending on the weight and duration of transport:

- Transport by hand (chapter not relevant for this axial piston unit)
- Transporting with lifting device (eye bolt or lifting strap)

Dimensions and weights

Table 6: Dimensions and weights A6VM series 65

Size		55	80	107	140	160	200
Weight	kg	28	36	46	61	62	78
Width	mm	The dimensions vary with the unit type. The values applicable for your axial piston unit can be found in the installation drawing (request if necessary).					
Height	mm						
Depth	mm						

Table 7: Dimensions and weights A6VM series 71

Size		60	85	115	150	170	215	280
Weight	kg	28	36	46	61	62	78	101
Width	mm	The dimensions vary with the unit type. The values applicable for your axial piston unit can be found in the installation drawing (request if necessary).						
Height	mm							
Depth	mm							

The weight specifications may vary depending on the unit type.

6.1.1 Transporting by hand

Axial piston units with a weight of up to 15 kg can be transported manually for a short time if necessary.

CAUTION! Danger from heavy loads!

There is a danger of health damage when carrying axial piston units.

- ▶ Use suitable lifting, placement and relocation equipment.
- ▶ Use your personal protective equipment (e.g., safety glasses, safety gloves, suitable working clothes, safety shoes).
- ▶ Do not transport the axial piston unit at sensitive attachment parts (e.g. sensors or valves).
- ▶ Carefully place the axial piston unit on the seating to prevent it from being damaged.

6.1.2 Transporting with lifting device

For transporting, the axial piston unit can be connected to a lifting device via an eye bolt or a lifting strap.

Transport with eye bolt

The axial piston unit can be transported suspended from an eye bolt screwed into the drive shaft as long as only outward (pulling) axial forces are applied.

- ▶ For all threaded holes, use a threaded plug from the same system of units and of the correct size.
- ▶ To do this, screw an eye bolt completely into the female thread on the drive shaft. The threaded size is stated in the installation drawing.
- ▶ Make sure that the eye bolt can bear the total weight of the axial piston unit plus 20 %.

You can hoist the axial piston unit as shown in Fig. 4 with the eye bolt screwed into the drive shaft.

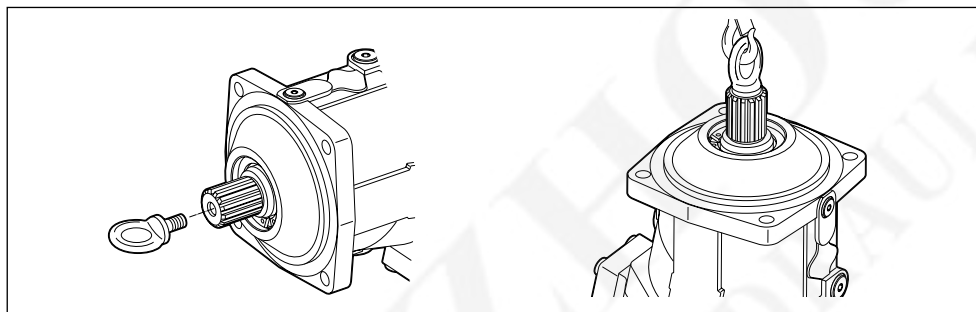

Fig. 4: Fixing the eye bolt

Transport with lifting strap

WARNING! Danger from suspended loads.

During transport with a lifting device, the axial piston unit can topple out of the lifting strap and cause injuries.

- ▶ Use the widest possible lifting strap.
- ▶ Make sure that the axial piston unit is securely fixated with the lifting strap.
- ▶ Only guide the axial piston unit by hand for fine positioning and to avoid oscillations.
- ▶ Never step or reach under a suspended load.
- ▶ Place the lifting strap around the axial piston unit in such a way that it neither passes over the attachment parts (e.g. valves) nor that the axial piston unit is hung from attachment parts (see Fig. 5).

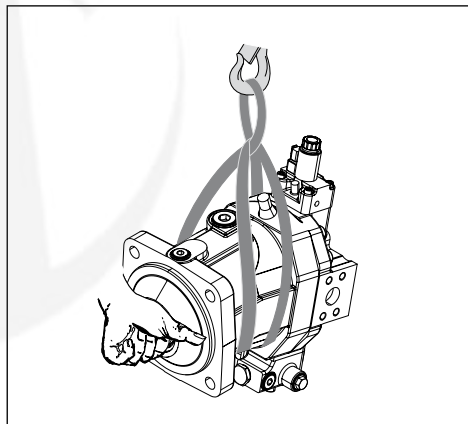

Fig. 5: Transport with lifting strap

6.2 Storing the axial piston unit

Requirements

- The storage areas must be free of corrosive materials and gases.
 - To prevent damage to the seals, ozone-forming equipment (e.g. mercury-vapor lamps, high voltage equipment, electric motors, sources of electrical sparks or electrical discharge) must not be operated in storage areas.
 - The storage areas must be dry.
 - Ideal storage temperature: +5 °C to +20 °C.
 - Minimum storage temperature: -50 °C.
 - Maximum storage temperature: +60 °C.
 - Avoid significant exposure to light (e.g. bright windows or direct fluorescent lighting).
 - Do not stack axial piston units and store them shock-proof.
 - Do not store the axial piston unit on the drive shaft or fitting, e.g. sensors or valves.
 - For further storage conditions, see Table 8.
- Check the axial piston unit monthly to ensure proper storage.

After delivery

The axial piston units are provided ex-works with corrosion protection packaging (corrosion protection film).

Table 8 lists the maximum permissible storage times for an originally packed axial piston unit as per data sheet 90312.

Table 8: Storage time with factory corrosion protection

Storage conditions	Standard corrosion protection	Long-term corrosion protection
Closed, dry room, uniform temperature between +5 °C and +20 °C. Undamaged and closed corrosion protection film.	Maximum 12 months	Maximum 24 months



Entitlement to warranty will be rendered void if the requirements and storage conditions are not adhered to or after expiration of the maximum storage time (see Table 8).

Procedure after expiry of the maximum storage time:

1. Check the entire axial piston unit for damage and corrosion prior to installation.
2. Check the axial piston unit for proper function and leaks during a test run.
3. If the storage time exceeds 24 months, the shaft seal must be replaced.



After expiry of the maximum storage time, we recommend that you have the axial piston unit inspected by your responsible Service partner.

In the event of questions regarding repair and spare parts, contact your responsible Service partner or the service department of the manufacturer's plant for the axial piston unit, see chapter 10.5 "Spare parts" on page 49.

After removal If a dismantled axial piston unit is to be stored, it must be preserved against corrosion for the duration of the storage.



The following instructions only refer to axial piston units which are operated with a mineral-oil based hydraulic fluid. Other hydraulic fluids require preservation methods that are specifically designed for them. In such cases, consult Service, see chapter 10.5 “Spare parts” on page 49.

recommends the following procedure:

1. Clean the axial piston unit, see chapter 10.1 “Cleaning and care” on page 47.
2. Empty the axial piston unit.
3. For storage periods up to 12 months: Moisten the inside of the axial piston unit with mineral oil and fill with approx. 100 ml mineral oil.
For storage periods up to 24 months: Fill the axial piston unit with corrosion protection VCI 329 (20 ml).
The filling is carried out via the reservoir port **T₁** or **T₂**, see chapter 7.4 “Installing the axial piston unit”, Fig. 11 to Fig. 14 on page 36.
4. Seal all ports so they are airtight.
5. Moisten the unpainted areas of the axial piston unit with mineral oil or with a suitable, easily removable corrosion protection agent, e.g. acid-free grease.
6. Package the axial piston unit airproof together with desiccant in corrosion protection film.
7. Store the axial piston unit so that it is protected against jolts, see “Requirements” on page 23 in this chapter.

7 Installation

Prior to installation, the following documents must be available:

- Installation drawing for axial piston unit (can be obtained from your responsible contact person)
- Hydraulic circuit diagram for the axial piston unit (in the installation drawing)
- Hydraulic circuit diagram for the machine/system (available from the machine/system manufacturer)
- Order confirmation (contains the order-related technical data for your axial piston unit)
- Data sheet of the axial piston unit (contains the permissible values of technical data)

7.1 Unpacking

The axial piston unit is delivered in a corrosion protection film made of polyethylene material (PE).

CAUTION! Danger from parts falling out.

If the packaging is not opened correctly, parts may fall out and damage the parts or even cause injuries.

- ▶ Place the packaging on a flat and solid surface.
- ▶ Only open the packaging from the top.

- ▶ Remove the packaging from the axial piston unit.
- ▶ Check the axial piston unit for transport damage and completeness, see chapter 4 “Scope of delivery” on page 17.
- ▶ Dispose of the packaging material according to the national regulations in your country.

7.2 Installation conditions

The installation location and position of the axial piston unit essentially determine the procedures during installation and commissioning (such as when filling and air bleeding the axial piston unit).

- ▶ Fix the axial piston unit so that the expected forces and torques can be transferred without any danger. The machine/system manufacturer is responsible for dimensioning the fasteners.
- ▶ Observe the permissible radial forces on the drive shaft when transferring output drive with radial force loading (belt drives). If necessary, the belt disc must be separately mounted.
- ▶ Make certain that the axial piston unit is air bled and filled with hydraulic fluid during commissioning and operation. This is also to be observed following relatively long standstill periods as the axial piston unit may empty via the hydraulic lines.
- ▶ The case drain fluid in the case interior must be directed to the reservoir via the highest case drain port. Use the line size which is appropriate for the port.

- ▶ Avoid using a check valve in the drain line.
Exception: Above-reservoir installation, drive shaft upward. A check valve in the drain line (cracking pressure 0.5 bar) can prevent draining via the drain line.
Please not the correct flow direction.
- ▶ To achieve favorable noise values, decouple all connecting lines from all vibration-capable components (e.g. reservoir) using elastic elements.
- ▶ Make sure that the reservoir and return lines lead into the reservoir below the minimum fluid level in all operating conditions. You prevent foam formation by doing this.
- ▶ Make sure that the working environment at the installation site is fully free of dust and foreign substances. The axial piston unit must be installed in a clean condition. Contamination of the hydraulic fluid can have a considerable impact on the function and service life of the axial piston unit.
- ▶ Use lint-free cloths for cleaning.
- ▶ Use suitable mild detergents to remove lubricants and other difficult-to-remove contamination. Cleaning agents must not enter the hydraulic system.

7.3 Installation position

The following installation positions are permissible. The shown piping layout illustrates the basic layout.



With installation positions 4 and 8 (shaft upwards) additional air bleeding is to be provided via the flushing port **U**.

7.3.1 Below-reservoir installation (standard)

Below-reservoir installation is when the axial piston unit is installed outside of the reservoir below the minimum fluid level.



Recommended installation position: 1 and 2.

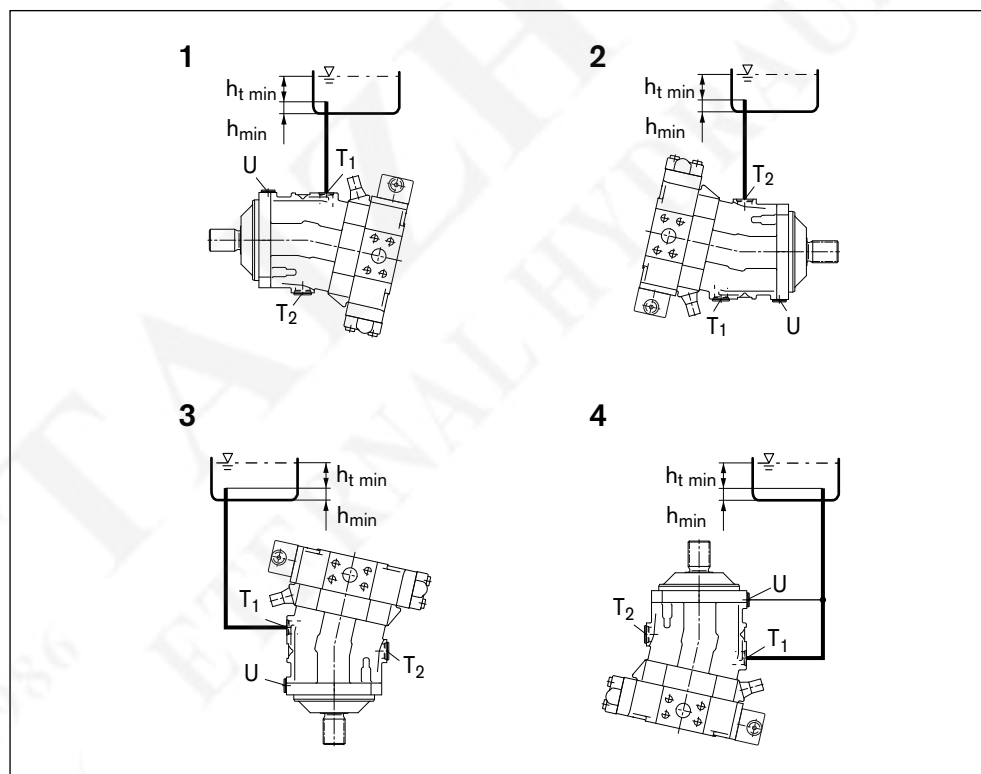

Fig. 6: Below-reservoir installation A6VM with installation position 1-4

T₁, T₂	Highest level drain port	h_{min}	Minimum required spacing to reservoir base (100 mm)
h_{t min}	Minimum necessary immersion depth (200 mm)	U	Bearing flushing / air bleed port

Table 9: Below-reservoir installation

Installation position	Air bleeding	Filling
1 (drive shaft, horizontal)	–	T ₁
2 (drive shaft, horizontal)	–	T ₂
3 (drive shaft vertically downward)	–	T ₁
4 (drive shaft vertically upward)	U	T ₁

7.3.2 Above-reservoir installation

Above-reservoir installation means the axial piston unit is installed above the minimum fluid level of the reservoir.



Recommendation for installation position 8 (shaft upward): A check valve in the drain line (cracking pressure 0.5 bar) can prevent draining of the case interior.

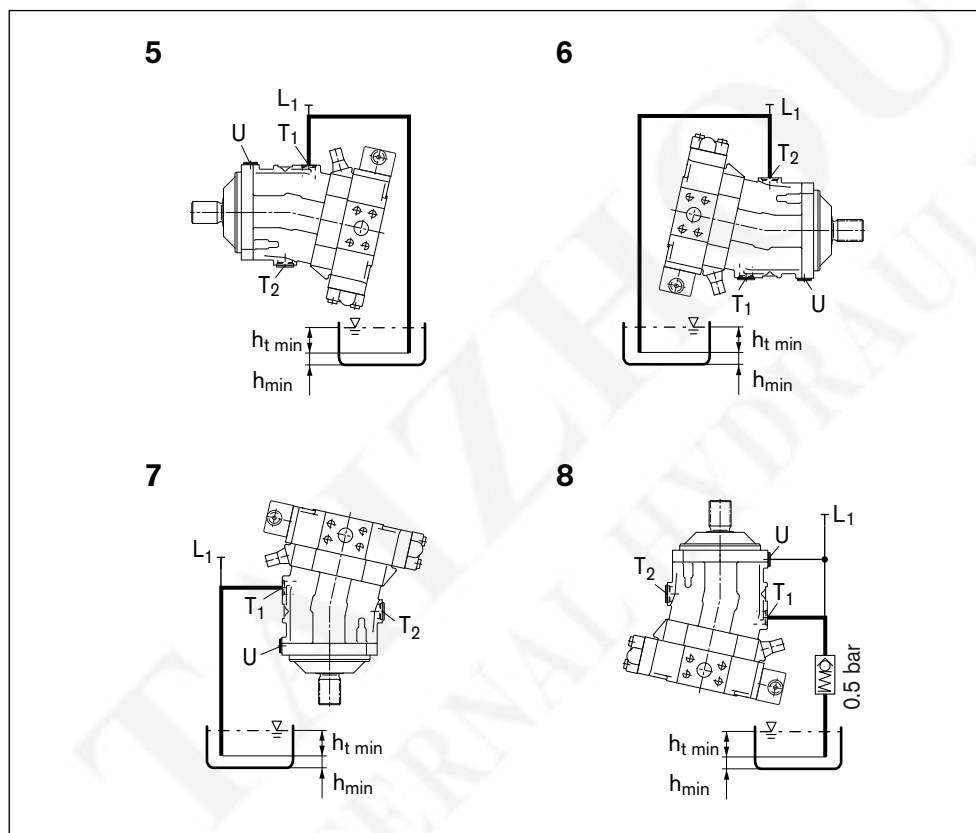

Fig. 7: Above-reservoir installation A6VM with installation position 5-8

L₁	Filling / air bleeding Note: L ₁ is part of the external piping	h_{t min}	Minimum necessary immersion depth (200 mm)
T₁, T₂	Highest level drain port	h_{min}	Minimum required spacing to reservoir base (100 mm)
U	Bearing flushing / air bleed port		

Table 10: Above-reservoir installation

Installation position	Air bleeding	Filling
5 (drive shaft, horizontal)	L ₁	T ₁ (L ₁)
6 (drive shaft, horizontal)	L ₁	T ₂ (L ₁)
7 (drive shaft vertically downward)	L ₁	T ₁ (L ₁)
8 (drive shaft vertically upward)	U	T ₁ (L ₁)

7.4 Installing the axial piston unit

7.4.1 Preparation

1. Compare the material number and designation (ordering code) with the details in the order confirmation.



If the material number for the axial piston unit does not correspond to the one in the order confirmation, contact Service for clarification, see chapter 10.5 “Spare parts” on page 49.

2. Before installing, completely empty the axial piston unit to prevent mixing with the hydraulic fluid used in the machine/system.

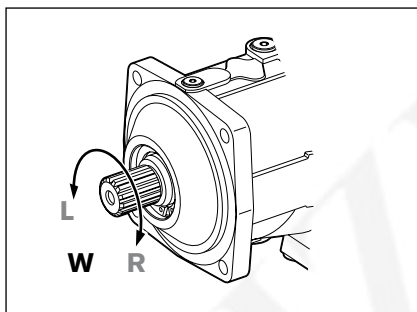

Fig. 8: Direction of rotation

- W** Bi-directional (counter-clockwise and clockwise rotation permissible)
L counter-clockwise
R clockwise



The direction of rotation as specified on the name plate determines the direction of rotation of the axial piston unit as viewed on the drive shaft, see chapter 5.3 “Product identification” on page 20.

7.4.2 Dimensions

The installation drawing contains the dimensions for all connections and ports on the axial piston unit. Also observe the manuals provided by the manufacturers of the other hydraulic components when selecting the required tools.

7.4.3 General notes

Please keep in mind the following general notes for installation of the axial piston unit:

- Note that you can expect certain installation positions to affect the control device. Gravity, dead weight and case pressure can cause minor shifts in control characteristic curves and changes in response time.
- After a short operating time, toothed belts lose a major portion of their pre-tension and thus cause speed variations and torsional vibrations. Torsional vibrations may cause leakages on the shaft seal or increased rotary angle accelerations of the rotary group of the axial piston unit.

- V-belt drives are also critical with respect to speed variations and torsional vibration. These can also lead to leakages on the shaft seal ring. An automatic tensioning device can lessen the speed variations and vibrations and thus avoid consequential damage.
 - When using toothed belts or v-belts to transfer the input or output drive, always use an automatic tensioning device.
- On the input or output drive of an axial piston unit, a cardan shaft may cause vibrations and impermissible rotary angle accelerations. Depending on the frequency and temperature, they may result in leakage on the shaft seal and damage to the rotary group.
- For combinations comprising several units, make sure that the respective case pressure is not exceeded. In the event of pressure differences at the reservoir ports of the units, the shared drain line must be changed so that the minimum permissible case pressure of all connected units is not exceeded in any situation. If this is not possible, separate drain lines must be laid if necessary.

The installation method for the axial piston unit depends on the connecting elements to the output drive side. The following descriptions explain the installation of the axial piston unit:

- with a clutch
- on a gearbox

7.4.4 Installation with coupling

How to install the axial piston unit with a coupling is described in the following:

NOTICE! Danger from improper handling.
Product can be damaged.

- ▶ Do not install the coupling hub onto the drive shaft of the axial piston unit by striking it.
- 1. Install the specified coupling half onto the drive shaft of the axial piston unit according to the instructions of the coupling manufacturer.



The drive shaft of the axial piston unit is equipped with a female thread. Use this female thread to pull the coupling element onto the drive shaft. The size of the female thread can be seen in the installation drawing.

- 2. Clamp the coupling hub onto the drive shaft or ensure permanent lubrication of the drive shaft. This prevents the formation of frictional corrosion and the associated wear.
- 3. Transport the axial piston unit to the installation location.
- 4. Remove dirt and contaminants from the installation location.
- 5. Install the coupling on the drive shaft of the machine/system in accordance with the specifications provided by the coupling manufacturer.



The axial piston unit must not be tightened down until the coupling has been correctly installed.

- 6. Fix the axial piston unit at the installation location.
- 7. Align the drive shaft of the axial piston unit and the drive shaft of the machine or system so that there is no angular deviation.
- 8. Make certain that no impermissible axial and radial forces act on the drive shaft.
- 9. Details on the required tools and tightening torques for the mounting bolts are available from the machine/system manufacturer.
- 10. When using flexible couplings, check that the drive is free of resonance after completing the installation.

7.4.5 Installation on a gearbox

The installation layout for the axial piston unit on a gearbox is described below.

After installing on a gearbox, the axial piston unit is covered and is difficult to access:

- ▶ Therefore, before installing, make sure that the centering diameter centers the axial piston unit (observe tolerances) and that no impermissible axial or radial forces act on the drive shaft of the axial piston unit (installation length).
- ▶ Protect the drive shaft against frictional corrosion by providing permanent lubrication.
- ▶ Fix the axial piston unit at the installation location.

For attachment via gear wheel or helical-toothed shaft

No gearing forces higher than the permissible axial and radial forces are to act on the shaft, if necessary the gear wheel must be supported separately at the gearbox output.

7.4.6 Installation with cardan shaft

To be connected around the axial piston unit with a cardan shaft:

1. Position the axial piston unit close to the specified installation point. It should allow enough space for the cardan shaft to fit through on both sides.
2. Join the cardan shaft to the drive shaft of the machine/system.
3. Push the axial piston unit to the cardan shaft and join the cardan shaft to the output shaft of the axial piston unit.
4. Bring the axial piston unit to the installation position and secure. If necessary, details on the required tools and tightening torques for the mounting bolts can be obtained from the system manufacturer.

7.4.7 Completing installation

1. Remove any mounted transport screws.

CAUTION! Operation with protective plug!

Operating the axial piston unit with protective plugs may result in injuries or damage to the axial piston unit.

- ▶ Before commissioning, remove all protective plugs and replace them with suitable, pressure-proof, metal threaded plugs.
2. Remove the transport protection.
The axial piston unit is delivered with protective covers **(1)** and protective plugs **(2)**. They are not pressure-resistant, therefore they have to be removed prior to connection. Use a suitable tool for this to prevent damage to the sealing and functional surfaces. If sealing or functional surfaces are damaged, contact your responsible Service partner or the service department of the manufacture's plant for the axial piston unit.

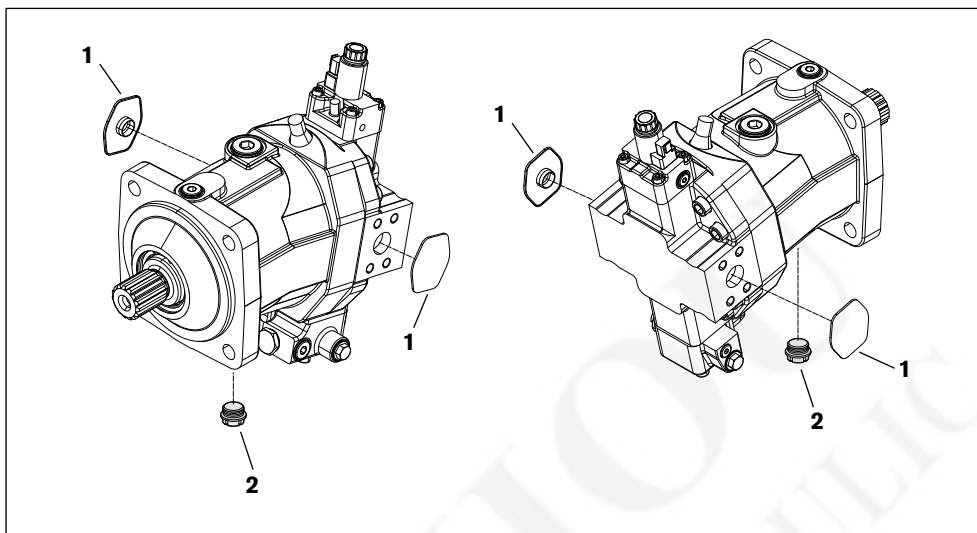

Fig. 9: Remove transport protection

1 Protective covers

2 Protective plugs/threaded plugs



Ports intended for connecting lines are covered by protection plugs or threaded plugs, which serve as transport protection. All ports required for functional operation must be connected (see Table 13 “Ports A6VM series 65” on page 37 and Table 14 “Ports A6VM series 71” on page 38). Failure to comply with this could lead to malfunctions or damage. If a port is not connected, it must be plugged with a threaded plug because protective plugs are not pressure-resistant.



Setting screws are protected against unauthorized resetting by means of protective caps. Removal of the protective caps will void the warranty. If you need to change settings, contact your responsible Service partner (for address, see chapter 10.5 “Spare parts” on page 49).

7.4.8 Hydraulically connecting the axial piston unit

The machine/system manufacturer is responsible for dimensioning the lines. The axial piston unit must be connected to the rest of the hydraulic system in accordance with the hydraulic circuit diagram of the machine/system manufacturer. The ports and fixing threads are designed for the peak pressure specified in the data sheet. The machine/system manufacturer must ensure that the connecting elements and lines correspond to the specified application conditions (pressure, flow, hydraulic fluid, temperature) with the necessary safety factors.



Connect only hydraulic lines that are appropriate for the axial piston unit port (pressure level, size, system of units).

Notes on routing the lines

Observe the following notes when routing the pressure and drain lines.

- Lines and hoses must be installed without pre-charge pressure, so that no further mechanical forces are applied during operation that will reduce the service life of the axial piston unit and, if applicable, the entire machine/system.
- Use suitable seals as sealing material.
- Pressure line
 - For the pressure lines, use only pipes, hoses and connecting elements rated for the operating pressure range specified in data sheets 91607 and 91610 (see Table 13 and Table 14).
- Drain line
 - Always route the drain lines so that the housing is constantly filled with hydraulic fluid and to ensure that no air gets through the shaft seal even during extended standstill periods.
 - In no operating condition may the case internal pressure exceed the maximum values specified for the axial piston unit in the data sheet.
 - The drain line joint in the reservoir must always be below the minimum fluid level under all conditions (see chapter 7.3 “Installation position” on page 27).
- If the axial piston unit is equipped with installed screw fittings, these must not be unscrewed. Screw the threaded plug of the fitting directly into the installed screw fitting.

Risk of mix-ups with threaded connections

Axial piston units are employed in regions using the metric measuring system, in regions using the Anglo-American (imperial) measuring system and in regions using the Japanese measuring system (JIS – Japan Industrial Standard).

Moreover, various kinds of seal are used.

The system of units, the kind of seal and the size of female thread and threaded plugs (e.g., threaded plug) must all match.

Due to the limited options for visually detecting differences, there is a risk of mix-ups.

WARNING! Leaking or popped-out threaded plugs!

If a threaded plug which is of a different measurement system, kind of seal and size with respect to the female thread is pressurized, the threaded plug may loosen itself or even be ejected from the hole in a projectile-like manner. This can result in serious injury and damage to equipment. Hydraulic fluid can be discharged from this leakage point.

- ▶ Use the drawings (installation drawing) to determine the required threaded plug for each fitting.
- ▶ Make certain that there are no mix-ups when installing fittings, mounting bolts and threaded plugs.
- ▶ For all threaded holes, use a threaded plug from the same system of units and of the correct size.

Mounting of the counterbalance valve

Note the following instructions on versions with counterbalance valve. When delivered, the counterbalance valve is mounted to the motor with two tacking screws (transport protection). The tacking screws may not be removed while mounting the working lines! If the counterbalance valve and motor are delivered separately, the counterbalance valve must first be mounted to the motor port plate using the provided tacking screws. The counterbalance valve is finally mounted to the motor by screwing on the SAE flange with the following screws:

- 6 screws **(1, 2, 3, 4, 5, 8)** length B1+B2+B3
- 2 screws **(6, 7)** length B3+B4

Tighten the screws in two steps in the specified sequence from 1 to 8 (see following diagram)!

- ▶ In the first step, tighten the screws with half the tightening torque; in the second step, tighten with the maximum tightening torque (see table Table 11).

Table 11: Tightening torques of the mounting bolts

Thread	Strength class	Tightening torque ¹⁾
M6 x 1 (tacking screw)	10.9	13.2 Nm
M10 x 1.5	10.9	63 Nm
M12 x 1.75	10.9	108 Nm
M14 x 2	10.9	172 Nm

¹⁾ The tightening torques for mounting bolts apply for the “slightly oiled” state as received on delivery. (friction coefficients $\mu = 0.10$)

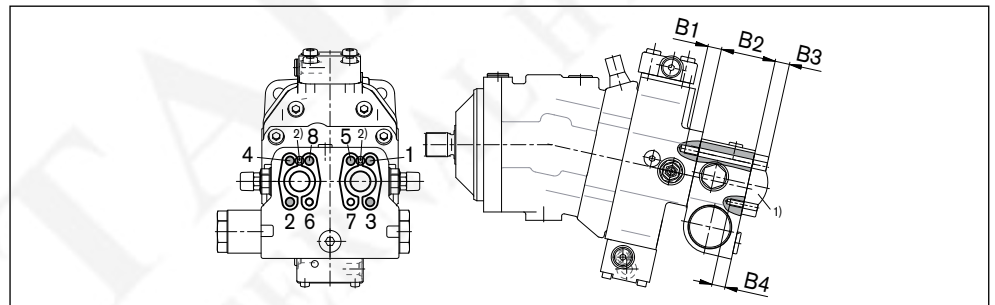

¹⁾ SAE flange

²⁾ Tacking screw (M6 x 1, length = B1 + B2, DIN 912)

Fig. 10: Mounting of the counterbalance valve



The SAE flange and corresponding mounting bolts are not included in the scope of delivery.

Table 12: Thread sizes and dimensions

Size	55...7, 60...7	80...7, 107...7 85...7, 115...7	107...8, 140...8 115...8, 170...8	160...8, 200...8
Dimension	M10 x 1.5, 17 deep	M12 x 1.75, 15 deep	M14 x 2, 19 deep	M14 x 2, 19 deep
Dimension B1 ¹⁾				
Dimension B2	68 mm	68 mm	85 mm	85 mm
Dimension B3	customer-specific			
Dimension B4	M10 x 1.5, 15 deep	M12 x 1.75, 16 deep	M14 x 2, 19 deep	M14 x 2, 19 deep

Fixing thread according to DIN 13. For mounting bolts with metric ISO threads according to DIN 13, we recommend checking the tightening torque individually in accordance with VDI 2230.

¹⁾ Minimum required thread reach 1 x \varnothing thread

Port overview

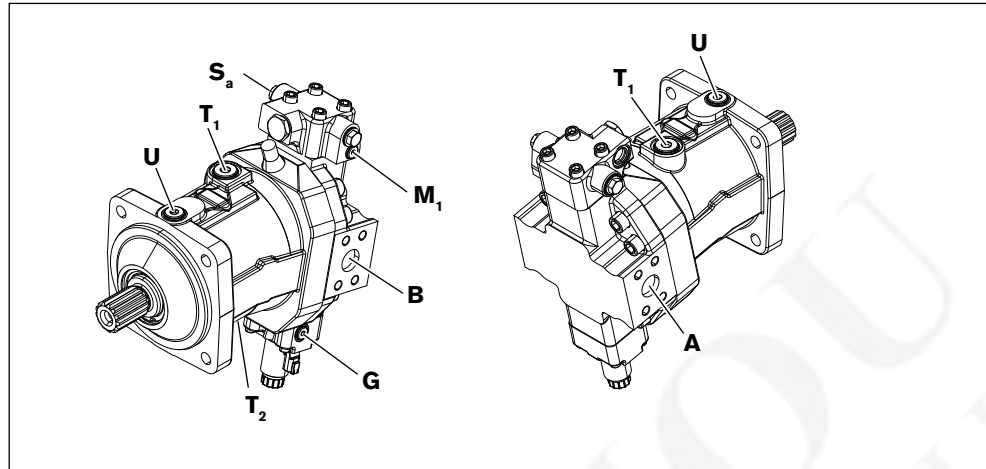

Fig. 11: Port overview A6VM with control EP1/EP2 and flushing valve, working line ports at side

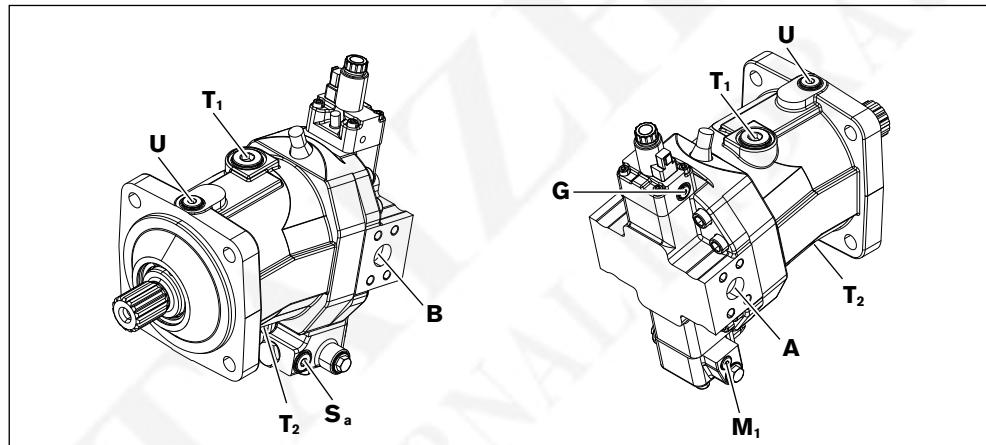

Fig. 12: Port overview A6VM with control EP5/EP6 and flushing valve, working line ports at side

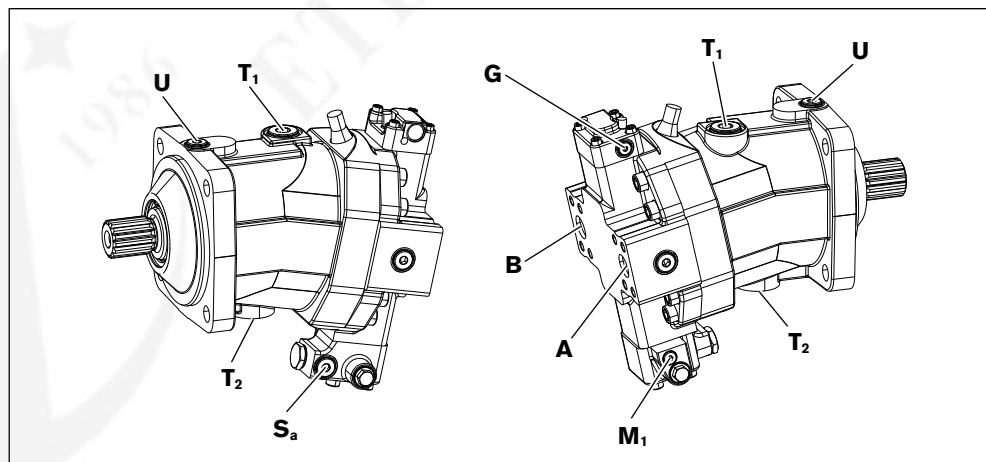

Fig. 13: Port overview A6VM with control HP5/HP6 and flushing valve, working line ports at side

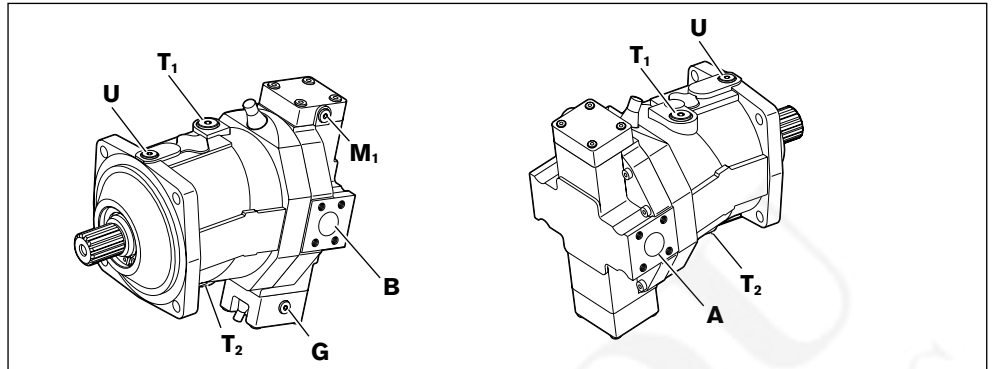

Fig. 14: Port overview A6VM with control HA, working line ports at side

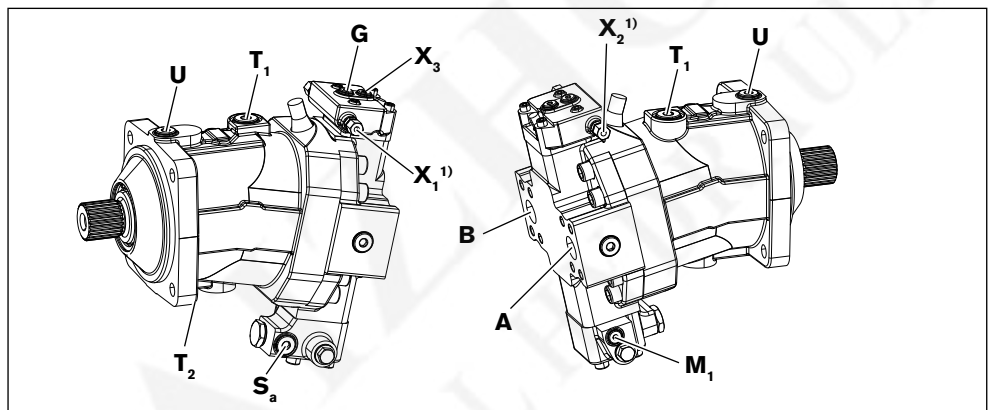

Fig. 15: Port overview A6VM with control DA and flushing valve, working line ports at rear

¹⁾ Use assembled screws, do not remove

Table 13: Ports A6VM series 65

Ports ¹⁾		p_{max} [bar] ²⁾	Status
A, B	Working line port	450	O
T ₁	Drain port	3	X ³⁾
T ₂	Drain port	3	O ³⁾
G	Synchronous control	450	X
U	Bearing flushing	3	X
X	Pilot signal (HP, HZ, HA1T/HA2T)	100	O
X	Pilot signal (HA1 and HA2)	3	X
X ₁ , X ₂	Pilot signal (DA0)	40	O
X ₁	Pilot signal (DA1, DA2)	40	O
X ₃	Pilot signal (DA1, DA2)	40	X
M ₁	Stroking chamber measurement	450	X
S _a	External flushing port	2	X
M _A	Measuring, pressure A	420	X
M _B	Measuring pressure B	420	X

¹⁾ The measuring system and thread size can be taken from the installation drawing.

²⁾ Depending on the application, short-term pressure spikes can occur. Keep this in mind when selecting measuring equipment and fittings.

³⁾ Depending on the installation position, T₁ or T₂ must be connected (see chapter 7.3 "Installation position" on page 27)

O = Must be connected (plugged on delivery)

X = Plugged (in normal operation)

Table 14: Ports A6VM series 71

Ports ¹⁾		p_{max} [bar] ²⁾	Status
A, B	Working line port	500	O
T ₁	Drain port	3	X ³⁾
T ₂	Drain port	3	O ³⁾
G	Synchronous control	500	X
U	Bearing flushing	3	X
X	Pilot signal (HP, HZ, HA1T/HA2T)	100	O
X	Pilot signal (HA1 and HA2)	3	X
X ₁ , X ₂	Pilot signal (DA0)	40	O
X ₁	Pilot signal (DA1, DA2)	40	O
X ₃	Pilot signal (DA1, DA2)	40	X
M ₁	Stroking chamber measurement	500	X
S _a	External flushing port	2	X
M _A	Measuring, pressure A	420	X
M _B	Measuring pressure B	420	X

¹⁾ The measuring system and thread size can be taken from the installation drawing.

²⁾ Depending on the application, short-term pressure spikes can occur. Keep this in mind when selecting measuring equipment and fittings.

³⁾ Depending on the installation position, T₁ or T₂ must be connected (see chapter 7.3 "Installation position" on page 27)

O = Must be connected (plugged on delivery)

X = Plugged (in normal operation)

Tightening torques

The following tightening torques apply:

- Fittings:
Observe the manufacturer's specifications regarding the tightening torques of the used fittings.
- Female threads in the axial piston unit:
The maximum permissible tightening torques $M_{G\ max}$ are maximum values of the threaded holes and must not be exceeded. Values, see Table 15.
- Threaded plugs:
For the metal threaded plugs, supplied with the axial piston unit, the required tightening torques of plugs M_v apply. Values, see Table 15.
- Mounting bolts:
For mounting bolts with metric ISO thread according to DIN 13 or thread according to ASME B1.1, we recommend checking the tightening torque in individual cases in accordance with VDI 2230.

Table 15: Tightening torques for female threads and threaded plugs

Ports Standard	Threaded size	Maximum permissible tightening torque of the threaded holes $M_{G\max}$	Required tightening torque of the threaded plugs M_V	WAF hexagon socket of the threaded plugs
ISO 6149	M8 x 1	10 Nm	7 Nm	4 mm
	M10 x 1	30 Nm	15 Nm	5 mm
	M12 x 1.5	50 Nm	25 Nm	6 mm
	M14 x 1.5	80 Nm	45 Nm	6 mm
	M16 x 1.5	100 Nm	55 Nm	8 mm
	M18 x 1.5	140 Nm	70 Nm	8 mm
	M20 x 1.5	170 Nm	80 Nm	10 mm
	M22 x 1.5	210 Nm	100 Nm	10 mm
	M27 x 2	330 Nm	170 Nm	12 mm
	M30 x 2	420 Nm	215 Nm	17 mm
	M33 x 2	540 Nm	310 Nm	17 mm
	M42 x 2	720 Nm	330 Nm	22 mm
	M48 x 2	900 Nm	420 Nm	22 mm
	DIN 3852 ¹⁾	M8 x 1	10 Nm	7 Nm
M10 x 1		30 Nm	15 Nm ²⁾	5 mm
M12 x 1.5		50 Nm	25 Nm ²⁾	6 mm
M14 x 1.5		80 Nm	35 Nm	6 mm
M16 x 1.5		100 Nm	50 Nm	8 mm
M18 x 1.5		140 Nm	60 Nm	8 mm
M22 x 1.5		210 Nm	80 Nm	10 mm
M26 x 1.5		230 Nm	120 Nm	12 mm
M27 x 2		330 Nm	135 Nm	12 mm
M33 x 2		540 Nm	225 Nm	17 mm
M42 x 2		720 Nm	360 Nm	22 mm
M48 x 2		900 Nm	400 Nm	24 mm

¹⁾ The tightening torques of the M_V threaded plugs apply for the screws in the “dry” state received on delivery and for the “lightly oiled” state for installation.

²⁾ In the “lightly oiled” state, M_V is reduced to 10 Nm or M10 x 1 to 17 Nm for M12 x 1.5. For the delivery condition “dry” and for reduced M_V , 10 Nm for M10 x 1 and 17 Nm for M12 x 1.5, the maximum permissible pressure is 420 bar.

Procedure

To connect the axial piston unit to the hydraulic system:

1. Remove the protective plugs and threaded plugs at the ports at which the connections are to be made according to the hydraulic circuit diagram.
2. Make certain that the sealing surfaces of the hydraulic ports and functional surfaces are not damaged.
3. Use only clean hydraulic lines or flush them before installation. (Note chapter 7.5 “Performing flushing cycle” on page 41 when you flush out the complete system.)
4. Connect the lines in accordance with the installation drawing and the machine or system circuit diagram. Check whether all ports are connected or plugged with threaded plugs.
5. Tighten the fittings correctly (note tightening torques). Mark all correctly tightened fittings, e.g. with a permanent marker.

6. Check all pipes and hose lines and every combination of connecting pieces, couplings or connecting points with hoses or pipes to ensure they are in condition for safe working.



Relationship between direction of rotation and flow direction:

Clockwise rotation: **A to B**

Counter-clockwise rotation: **B to A**

7.4.9 Electrically connecting the axial piston unit

NOTICE

Short circuit in event of penetrating hydraulic fluid!

Fluid can penetrate the product and cause a short circuit!

- Do not install axial piston units with electric components (e.g. electric controls, sensors) in a reservoir below the fluid level (inside-reservoir installation).

The machine/system manufacturer is responsible for the layout of the electric control.

Electrically controlled axial piston units must be connected in accordance with the electrical circuit diagram for the machine/system.

For axial piston units with electrical control and/or mounted sensors, please comply with the details given in data sheets 91607 and 91610, e.g.:

- the permissible voltage range
- the permissible current
- the correct connection
- the recommended electrical control units

Exact details on the connector, type of protection and matching mating connector can also be found in data sheets 91607 and 91610. The mating connector is not included in the scope of delivery.

1. Switch off power supply to the relevant system component.
2. Electrically connect the axial piston unit (12 or 24 V). Before connection, check that the connector including all seals are intact.

Changing connector orientation

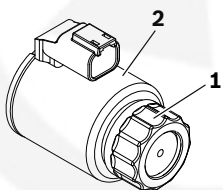

If necessary, you can change the connector orientation by turning the solenoid housing. This is dependent on the connector version.

To do this, proceed as follows:

1. Loosen the mounting nut (**1**) of the solenoid. To do this, turn the mounting nut (**1**) one turn counter-clockwise.
2. Turn the solenoid body (**2**) to the desired orientation.
3. Retighten the mounting nut. Tightening torque of the mounting nut: 5+1 Nm.

7.5 Performing flushing cycle

In order to remove foreign particles from the system, recommends a flushing cycle for the entire system before the first commissioning. To avoid internal contamination, the axial piston unit must not be included in the flushing cycle.



The flushing cycle must be performed with an additional flushing unit. Follow the instructions of the flushing unit's manufacturer for the exact procedure during the flushing cycle.

8 Commissioning

WARNING

Danger while working in the danger zone of a machine/system!

Danger to life, risk of injury or serious injuries!

- ▶ Pay attention to and rectify potential danger sources before operating the axial piston unit.
- ▶ Nobody may stand in the danger zone of the machine/system.
- ▶ The emergency stop button for the machine/system must be within the operator's reach.
- ▶ Always follow the instructions of the machine/system manufacturer during commissioning.

CAUTION

Commissioning of an incorrectly installed product!

Risk of injury and damage to equipment!

- ▶ Make sure that all electrical and hydraulic ports are connected or plugged.
- ▶ Only commission a completely installed fault-free product with original accessories .

8.1 Initial commissioning



During all work for commissioning the axial piston unit, observe the general safety instructions and intended use detailed in chapter 2 "Safety instructions" on page 8.

- ▶ Connect the gauge for the operating pressure and case pressure to the specified measuring points on the axial piston unit or in the hydraulic system, to check the technical data at first operation.
- ▶ During the commissioning process, monitor the temperature of the hydraulic fluid in the reservoir to ensure that it lies within the permissible viscosity limits.

8.1.1 Filling the axial piston unit

Professional filling and air bleeding is necessary to prevent damage to the axial piston unit and to maintain correct function.



The axial piston unit should be filled with a filling unit (10 µm filter grade).
The axial piston unit must not be operated while it is being filled by the filling unit.

Use only a hydraulic fluid that conforms to the following requirements:
You can find details of the minimum requirements on hydraulic fluids in data sheets 90220, 90221, 90222, and 90223. The titles of the data sheet can be found in Table 1 “Required and supplementary documentation” on page 5. You can find details of permissible and optimal viscosity in data sheets 91607 and 91610. To ensure the functional reliability of the axial piston unit, cleanliness level 20/18/15 according to at least ISO 4406 is necessary for the hydraulic fluid. At very high hydraulic fluid temperatures (+90 °C to maximum +115 °C), cleanliness level 19/17/14 according to at least ISO 4406 is necessary. For permissible temperatures, see data sheets 91607 and 91610.

1. Place a drip tray under the axial piston unit to collect any hydraulic fluid that may leak.

NOTICE! Contaminated hydraulic fluid!

The cleanliness levels of hydraulic fluids on delivery do not normally conform to the requirements for our components.

- ▶ Use a suitable filter system to filter hydraulic fluids during filling to minimize solid impurities and water in the hydraulic system.

2. Fill and air bleed the axial piston unit via the appropriate ports, see chapter 7.3 “Installation position” on page 27. The hydraulic lines of the system must also be filled.

For installation position “drive shaft vertically upward”: Air bleed the housing via the port **U**. Air bleeding is not necessary for other installation positions; the housing is bled automatically via the drain line.

NOTICE! Damage to equipment due to improper lubrication!

Product can be damaged or destroyed.

- ▶ When using a shut-off valve in the drain line, makes sure that the input of the axial piston unit can only be started when the shut-off valves are open.

3. When using a shut-off valve in the drain line, only operate the axial piston unit when the shut-off valves are open.

8.1.2 Testing the hydraulic fluid supply

The axial piston unit must always have a sufficient supply of hydraulic fluid. For this reason, the supply of hydraulic fluid must be ensured at the start of the commissioning process.

When you test the hydraulic fluid supply, constantly monitor the noise development and check the hydraulic fluid level in the reservoir. If the axial piston unit becomes louder (cavitation) or the case drain fluid is discharged with bubbles, this is an indication that the axial piston unit is not being sufficiently supplied with hydraulic fluid.

For information on troubleshooting, see chapter 14 “Troubleshooting” on page 52.

To test the hydraulic fluid supply:

1. Allow the axial piston unit to run at low speed and without load. Pay attention to leakage and noise.
2. Check the axial piston unit's drain line during the test. The case drain fluid should not contain any bubbles.
3. Increase the load and check whether the operating pressure rises as expected.
4. Carry out a leak test to ensure that the hydraulic system is sealed and can withstand the maximum pressure.
5. Check the case drain pressure at port **T₁**, **T₂** or **U** at maximum pressure. Refer to the data sheets 91607 and 91610 for the permissible value.

8.1.3 Performing functional test

WARNING

Incorrectly connected axial piston unit!

Mixing up the ports will lead to malfunctions (e.g. lift instead of lower) and thus to corresponding danger to persons and equipment!

- ▶ Before the functional test, check whether the piping specified in the hydraulic circuit diagram has been installed.

Once you have tested the hydraulic fluid supply, you must perform a functional test on the machine/system. The functional test should be performed according to the instructions of the machine/system manufacturer.

The axial piston unit is checked for functional capability before delivery according to the technical data. During commissioning, it must be ensured that the axial piston unit was installed properly in the machine/system.

- ▶ After starting the engine, check in particular the specified pressures, e.g. system pressure, boost pressure and case pressure.
- ▶ If necessary, disconnect the gauge and plug the ports with threaded plugs.

8.2 Running-in phase

NOTICE

Damage to equipment by insufficient viscosity!

An increased hydraulic fluid temperature may reduce the viscosity values by too much and damage the product!

- ▶ Monitor the operating temperature during the running-in phase, e.g. by measuring the case drain temperature.
- ▶ Reduce the loading (pressure, rpm) of the axial piston unit if impermissible operating temperatures and/or viscosities occur.
- ▶ Operating temperatures that are too high indicate faults that have to be analyzed and cleared.

The bearings and sliding surfaces are subject to a running-in phase. The increased friction at the start of the running-in phase results in increased heat development which decreases with increasing operating hours. The volumetric and mechanical-hydraulic efficiency increases as well through the conclusion of the running-in phase of approx. 10 operating hours.

To ensure that contamination in the hydraulic system does not damage the axial piston unit, recommends the following procedure after the running-in phase:

- ▶ After the running-in phase, have a hydraulic fluid specimen analyzed for the required cleanliness level.
- ▶ Change the hydraulic fluid if the required cleanliness level is not reached. If a laboratory test is not carried out after the running-in phase, recommends the hydraulic fluid be changed.

8.3 Recommissioning after standstill

Depending on the installation conditions and ambient conditions, changes may occur in the hydraulic system which make recommissioning necessary.

Among others, the following criteria may make recommissioning necessary:

- Air and/or water in the hydraulic system
 - Old hydraulic fluid
 - Other contamination
- ▶ Before recommissioning, proceed as described in chapter 8.1 “Initial commissioning” on page 42.

9 Operation

WARNING

Overloading of the axial piston motor!

Risk of injury or damage to equipment!

When using the axial piston motor in winch drives it can, when extremely overloaded (e.g. if the maximum permissible rotational speeds are exceeded during weighing of the anchor while the ship is in motion) cause damage to the rotary group and in the worst case, the axial piston motor may burst.

- ▶ Ensure that the technical limits are not exceeded in any operating conditions.
- ▶ Check whether any additional measures are needed for your machine/system (up to an encapsulation) in order to avoid injury to persons. If necessary, make sure that these are properly implemented.
- ▶ For safety reasons, axial piston variable motors with beginning of control at $V_{g\min}$ (e.g., HA) are not permissible for winch drives (e.g. anchor winches).

The product is a component which requires no settings or changes during operation. For this reason, this chapter of the instructions does not contain any information on adjustment options. Use the product only within the performance range provided in the technical data. The machine/system manufacturer is responsible for the proper project planning of the hydraulic system and its control.

10 Maintenance and repair

NOTICE

Inspection and maintenance work carried out too late!

Damage to equipment.

- ▶ Carry out the specified inspection and maintenance work at the intervals described in this manual.

10.1 Cleaning and care

NOTICE

Damage to seals and electrical system by mechanical effects!

The water jet of a power washer may damage the seals and electrical system of the axial piston unit!

- ▶ Do not point the power washer at sensitive components, e.g. shaft seal, electrical connections and components.

For cleaning and care of the axial piston unit, observe the following:

- ▶ Check whether all seals and plugs of the plug connections are securely seated to ensure that no moisture can penetrate into the axial piston unit during cleaning.
- ▶ Use only water and, if necessary, a mild detergent to clean the axial piston unit. Never use solvents or aggressive cleaning agents.
- ▶ Remove external coarse dirt and keep sensitive and important components, such as solenoids, valves and sensors, clean.

10.2 Inspection

In order to enable long and reliable operation of the axial piston unit, recommends testing the hydraulic system and axial piston unit on a regular basis, and documenting and archiving the following operating conditions:

Table 16: Inspection schedule

Task to be carried out	Interval	
Hydraulic system	Check level of hydraulic fluid in the reservoir.	Daily
	Check the operating temperature at a comparable load condition at the reservoir port and in the reservoir.	Weekly
	Conduct analysis of hydraulic fluid: viscosity, aging and dirt contamination	Yearly or every 2000 operating hours (whichever occurs first)
	Check filter. The change interval may vary depending on the degree of contamination of the hydraulic fluid. We recommend using a contamination indicator.	Yearly or every 1000 operating hours (whichever occurs first)

Task to be carried out		Interval
Axial piston unit	Check axial piston unit for leakage. Early detection of hydraulic fluid loss can help to find faults on the machine/system and to rectify them. For this reason, recommends that the axial piston unit and system are always kept in a clean condition.	Daily
	Check axial piston unit for unusual noise development.	Daily
	Check fixing elements for tight seating. All fasteners have to be checked when the hydraulic system is switched off, depressurized and cooled down.	Monthly

10.3 Maintenance

The axial piston unit is low maintenance when used properly.

The service life of the axial piston unit is heavily dependent on the quality of the hydraulic fluid. For this reason, we recommend changing the hydraulic fluid at least once per year or every 2000 operating hours (whichever occurs first) or having it analyzed by the hydraulic fluid manufacturer or a laboratory to determine its suitability for further use.

The service life of the axial piston unit is limited by the service life of the bearings fitted. The service life on the basis of the load cycle can be requested from the responsible Service partner, see chapter 10.5 “Spare parts” on page 49 for address. Based on these details, a maintenance period is to be determined by the system manufacturer for the replacement of the bearings and included in the maintenance schedule of the hydraulic system.

10.4 Repair

offers a comprehensive range of services for the repair of axial piston units.

Repairs on the axial piston unit and its fittings may only be performed by service centers certified by.

- ▶ Use exclusively original spare parts to repair the axial piston units, otherwise the functional reliability of the axial piston unit can not be assured and you lose your claim under warranty.

In the event of questions regarding repair, contact your responsible Service partner or the service department of the manufacture's plant for the axial piston unit, see chapter 10.5 “Spare parts” for further information.

10.5 Spare parts

CAUTION

Use of unsuitable spare parts!

Spare parts, which do not comply with the requirements as laid down by can cause damage to persons and equipment.

- ▶ Use exclusively original spare parts to repair the axial piston units, otherwise the functional reliability of the axial piston unit can not be assured and you lose your claim under warranty.

The spare parts lists for axial piston units are order specific. When ordering spare parts, quote the material and serial number of the axial piston unit as well as the material numbers of the spare parts.

Address all questions regarding spare parts to your responsible Service partner or the service department of the manufacture's plant for the axial piston unit.

Details of the manufacture's plant can be found on the name plate of the axial piston unit.

11 Removal and replacement

11.1 Required tools

Removal can be performed using standard tools. No special tools are necessary.

11.2 Preparing for removal

1. Decommission the entire system as described in the instruction manual for the machine or system.
 - Relieve pressure in the hydraulic system according to the instructions of the machine or system manufacturer.
 - Make certain that the relevant system components are not under pressure or voltage.
2. Protect the entire system against being re-energized.

11.3 Carrying out removal

Proceed as follows to remove the axial piston unit:

1. Check whether the hydraulic system is depressurized.
2. Allow the axial piston unit to cool down until it can be removed without danger.
3. For below-reservoir installation, before removing the axial piston unit from the complete system, seal the connection to the reservoir or drain the reservoir.
4. Place a drip tray under the axial piston unit to collect any hydraulic fluid that may leak.
5. Loosen the lines and collect the escaping hydraulic fluid in the drip tray.
6. Remove the axial piston unit. Use a suitable lifting device.
7. Completely empty the axial piston unit.
8. Plug all openings.

11.4 Preparing the components for storage or further use

- ▶ Proceed as described in chapter 6.2 “Storing the axial piston unit” on page 23.

12 Disposal

Careless disposal of the axial piston unit, the hydraulic fluid and the packaging material could lead to pollution of the environment.

Observe the following points when disposing of the axial piston unit:

1. Completely empty the axial piston unit.
2. Dispose of the axial piston unit and packaging material in accordance with the national regulations in your country.
3. Dispose of the hydraulic fluid according to the national regulations in your country. Also observe the applicable safety data sheet for the hydraulic fluid.
4. Disassemble the axial piston unit into its individual parts and properly recycle these parts.
5. Separate according to, for instance:
 - Cast parts
 - Steel
 - Aluminum
 - Nonferrous metal
 - Electronic waste
 - Plastic
 - Seals

13 Extension and conversion

Do not modify the axial piston unit or its fittings. This includes also the change of the setting screws and the wiring.



warranty only applies to the delivered configuration. In case of conversion or extension, the entitlement under warranty will be rendered void.



Setting screws are protected against unauthorized resetting by means of protective caps. Removal of the protective caps will void the warranty. If you need to change settings, contact your responsible Service partner (for address, see chapter 10.5 “Spare parts” on page 49).

14 Troubleshooting

Table 17 and may help you when troubleshooting. The table makes no claim for completeness.

In practical use, problems which are not listed here may also occur.

14.1 How to proceed with troubleshooting

- ▶ Always act systematically and in a targeted way, even under pressure of time. Random and imprudent removal and a readjustment of settings could result in the inability to ascertain the original failure cause.
- ▶ First obtain a general overview of how your product works in conjunction with the entire system.
- ▶ Try to find out whether the product was working properly in conjunction with the entire system before the problem occurred.
- ▶ Try to determine any changes to the entire system in which the product is installed.
 - Have there been any changes to the product's operating conditions or operating range?
 - Has maintenance work recently been carried out? Is there an inspection or maintenance log?
 - Have any changes (e.g. upgrades) or repairs been made to the overall system (machine/system, electrics, control) or to the product? If so, what were they?
 - Has the hydraulic fluid been changed?
 - Has the product or machine been used as intended?
 - How did the malfunction appear?
- ▶ Try to get a clear idea of the cause of the fault. Directly ask the (machine) operator.
- ▶ Document the work carried out.
- ▶ If you cannot rectify the fault, contact one of the contact addresses which can be found at: www.boschrexroth.com/addresses.

14.2 Malfunction table

Table 17: Axial piston unit malfunction table

Malfunction	Possible cause	Remedy
Unusual noises	Insufficient bleeding of the hydraulic system	Axial piston unit, suction line for the hydraulic pump and filling the reservoir Completely air bleed axial piston unit and hydraulic system. Check correct installation position
	Output speed too high	Machine/system manufacturer: Reduce volume flow
	Improper mounting of the axial piston unit.	Check the mounting of the axial piston unit according to the specifications of the machine/system manufacturer (observe tightening torques).
	Improper mounting of the accessory parts, hydraulic lines or wrong installation of the coupling	Fix attachment parts according to the information provided by the coupling or fitting manufacturer.
	Mechanical damage to the axial piston unit (e.g. bearing damage).	Replace axial piston units Contact Service.
No or insufficient pressure	Insufficient bleeding of the hydraulic system	Axial piston unit, suction line for the hydraulic pump and filling the reservoir Check correct installation position
	Faulty mechanical output drive (e.g. defective coupling).	Contact machine/system manufacturer.
	Drive power too low	Contact machine/system manufacturer.
	Malfunction of the control device or controller of the axial piston unit.	Contact Service.
	Control of the control device defective	Check control (machine/system manufacturer or contact Service)
	Wear or mechanical damage to the axial piston unit.	Replace axial piston units Contact Service.
	Drive unit defective (e.g. hydraulic pump)	Contact machine/system manufacturer.
Pressure/flow fluctuations resp. instabilities	Insufficient bleeding of the hydraulic system	Axial piston unit, suction line for the hydraulic pump and filling the reservoir Completely air bleed axial piston unit and hydraulic system. Check correct installation position
	Unstable control signal	Contact machine/system manufacturer resp. Service
	Malfunction of the control devices or the controller.	Contact Service.

Table 17: Axial piston unit malfunction table

Malfunction	Possible cause	Remedy
Rotational speed or torque cannot be reached	Insufficient flow at hydraulic pump.	Check function of the hydraulic pump.
	Minimum or maximum displacement set incorrectly.	Contact Service.
	Control of the control device defective	Check control (machine/system manufacturer)
	Insufficient pilot pressure or control pressure.	Check pilot pressure or control pressure Contact Service.
	Malfunction of the control device or controller of the axial piston motor.	Contact Service.
	Hydraulic fluid not in optimum viscosity range.	Machine/system manufacturer: Check temperature range and use suitable hydraulic fluid
	Wear or mechanical damage to the axial piston motor.	Replace axial piston units Contact Service.
	Wear or mechanical damage to the axial piston pump.	Replace hydraulic pump Contact Service.
	Wrong direction of rotation.	Check function of the hydraulic pump. Machine/system manufacturer: Check correct direction of rotation, see chapter 7.4.1 "Preparation" on page29
Excessive temperature of hydraulic fluid and case	Excessive inlet temperature at the axial piston unit.	Machine/system manufacturer: Inspect system, e.g malfunction of the cooler, insufficient hydraulic fluid in the reservoir.
	Wrong setting or malfunction of the pressure relief and pressure control valves (e.g. high-pressure relief valve, pressure cut-off, pressure controller)	Optimize the adjustment of the pressure relief and pressure control valves of the axial piston unit and the pressure safeguarding in the hydraulic system Contact Service. Contact machine/system manufacturer.
	Output speed too high.	Contact machine/system manufacturer.
	Flushing flow of the flushing valve too low	Contact Service.
	Wear of axial piston unit.	Exchange axial piston unit, contact Service.

15 Technical data

The permissible values of the technical data of your axial piston unit can be found in data sheet 91607 (A6VM series 65) and 91610 (A6VM series 71).

16 Alphabetical index

▶ A		▶ I	
Abbreviations	7	Identification	20
Above-reservoir installation	28	Information	
		– General	29
▶ B		Inspection	47
Below-reservoir installation	27	Installation	25, 29
		– Completing	32
▶ C		– General instructions	29
Care	47	– On a gearbox	32
Circuit		– On gearbox	32
– Closed	18	– Preparation	29
– Open	18	– With cardan shaft	32
Cleaning	47	– With coupling	31
Commissioning	42	Installation conditions	25
– Initial	42	Installation position	
Connecting		– Above-reservoir installation	28
– Electrical	40	– Below-reservoir installation	27
– Hydraulic	33	Intended use	8
Control	19		
Control piston	18	▶ L	
Conversion	51	Layout	18
Corrosion protection	23	Lens plate	18
Corrosion protection film	23	Lifting gear	21
Cylinder	18	Lifting strap	22
▶ D		▶ M	
Damage to equipment	14	Maintenance	47, 48
Designations	7	Malfunction table	53
Dimensions	21, 29	Motor function	19
Direction of rotation	29		
Dismantling	50	▶ N	
– Performing	50	Name plate	20
– Preparing	50		
Disposal	51	▶ O	
Drive shaft	18	Operation	46
▶ E		▶ P	
Eye bolt	22	Performance description	18
		Piston	18
▶ F		Port overview	36
Fault finding	52	Port plate	18
Filling	42	Product description	18
Flushing cycle	41		
Functional description		▶ Q	
– Control	19	Qualifications	9
– Motor function	19		
Functional test	44		

▶ R		
Recommissioning		
– after standstill	45	
Repair	48	
Replacement	50	
Required documentation	5	
Running-in phase	45	
▶ S		
Safety instructions	8	
– General	9	
– Product-specific	10	
– Signal word	6	
Scope of supply	17	
Solenoid position		
– Changing	40	
Spare parts	49	
Storage	21	
Storage time	23	
Storing	23	
Stroke piston	18	
Symbols	7	
▶ T		
Technical data	55	
Tightening torques	38	
Tools	50	
Transportation	21	
– By hand	21	
– With eye bolt	22	
– With lifting strap	22	
Transporting	21	
Transport protection	33	
Troubleshooting	52	
▶ U		
Unpacking	25	
▶ W		
Warranty	16, 33, 51	
Weight	21	