

Hydraulic cylinder Mill type



Series CDH1 / CGH1 / CSH1



H4646_d

- ▶ Component series 3X
- ▶ Nominal pressure 250 bar (25 MPa)

Features

- ▶ 6 types of mounting
- ▶ Piston Ø (**ØAL**): 40 to 320 mm
- ▶ Piston rod Ø (**ØMM**): 22 to 220 mm
- ▶ Stroke lengths up to 6 m
- ▶ Self-adjusting and adjustable end position cushioning
- ▶ IO-Link interface, optional

Contents

Features	1	Flange ports	42, 43
Contents	1	Subplates for valve mounting	44 ... 47
Ordering code series CDH1	2 ... 4	Bleeding / measuring coupling	48
Ordering code series CGH1	5 ... 7	Throttle valve	48
Ordering code series CSH1	8 ... 10	Proximity switch	49 ... 51
Technical data	11 ... 15	Position measurement system	52, 53
Overview types of mounting: Series CDH1 / CSH1	16	Profibus	54, 55
Overview types of mounting: Series CSH1	17	IO-Link, Profinet	56 ... 58
Swivel eye at base CDH1: MP3	18, 19	Plain clevis CSA	59
Self-aligning clevis at base CDH1: MP5	20, 21	Plain clevis CGA	60
Round flange at head CDH1/CGH1: MF3	22, 23	Swivel head CGAK	61, 62
Round flange at base CDH1: MF4	24, 25	Swivel head CGAS (clampable)	63, 64
Trunnion mounting CDH1/CGH1: MT4	26, 27	Buckling	65
Foot mounting CDH1/CGH1: MS2	28, 29	Admissible stroke length	66 ... 67
Swivel eye at base CSH1: MP3	30, 31	End position cushioning	68 ... 70
Self-aligning clevis at base CSH1: MP5	32, 33	Selection criteria for seals	71
Round flange at head CSH1: MF3	34, 35	Seal kits	72 ... 76
Round flange at base CSH1: MF4	36, 37	Tightening torques	77
Trunnion mounting CSH1: MT4	38, 39	Components	78 ... 81
Foot mounting CSH1: MS2	40, 41	Cylinder weight	82
		Corrosivity categories	83

Ordering code series CDH1

01	02	03	04	05	06	07	08	09	10	11	12	13	14	15	16
CD	H1		/		/		/	A	3X	/					

01	Differential cylinder	CD
----	-----------------------	-----------

02	Series	H1
----	--------	-----------

Types of mounting

03	Swivel eye at base	MP3 ¹⁾
	Self-aligning clevis at base	MP5
	Round flange at head	MF3
	Round flange at base	MF4
	Trunnion mounting	MT4 ²⁾
	Foot mounting	MS2

04	Piston Ø (ØAL) 40 ... 320 mm	
----	-------------------------------------	--

05	Piston rod Ø (ØMM) 22 ... 220 mm	
----	---	--

06	Stroke length in mm ³⁾	
----	-----------------------------------	--

07	Design principle: Head and base flanged	A
----	---	----------

08	Component series 30 ... 39 (30 ... 39: unchanged installation and connection dimensions)	3X
----	--	-----------

Line connection / version

09	According to ISO 1179-1 (pipe thread ISO 228-1)	B	
	According to ISO 9974-1 (metric thread ISO 261)	M	
	Flange hole pattern according to ISO 6162-2 tab. 2 type 1 (≅SAE 6000 PSI)	D ^{4; 9)}	
	Flange hole pattern according to ISO 6164 tab. 2	H ⁴⁾	
	According to ISO 1179-1 (pipe thread ISO 228-1) with flat pipe flange	C ³¹⁾	
	With mounted control block	Y ³⁸⁾	
	for directional and control valves		
	Subplate NG6	P ^{4; 5)}	
	Subplate NG10	T ^{4; 6)}	
	Subplate NG16	U ^{4; 7)}	
	Subplate NG25	V ^{4; 8)}	
	for SL and SV valves		
	Subplate NG6	A ^{4; 5; 15)}	
	Subplate NG10	E ^{4; 6; 15)}	
	Subplate NG20	L ^{4; 7; 15)}	
	Subplate NG30	N ^{4; 8; 15)}	

Line connection / position at head

10	View to piston rod ³⁰⁾		1
			2
			3
			4

Line connection/position at base

11	View to piston rod ³⁰⁾		1
			2 ³⁴⁾
			3
			4 ³⁴⁾

Ordering code series CDH1

01	02	03	04	05	06	07	08	09	10	11	12	13	14	15	16
CD	H1		/		/		/		A	3X	/				

Piston rod design

12	Hard chromium-plated	C
	Hardened and hard chromium-plated ¹²⁾	H
	Nickel-plated and hard chromium-plated ¹⁹⁾	N

Piston rod end

13	Thread for swivel head CGAS	A
	Thread for swivel head CGA, CGAK, plain clevis CSA	G ¹³⁾
	With mounted swivel head CGAS	S
	With mounted swivel head CGA	L ¹³⁾
	With mounted swivel head CGAK	M ¹³⁾
	With mounted plain clevis CSA	N ¹⁾

End position cushioning

14	Without	U
	Both sides, self-adjusting	D ¹⁾
	Both sides, adjustable	E
	Base sides, self-adjusting	K ^{1; 38)}
	Head sides, self-adjusting	S ^{1; 38)}

Seal design - observe selection criteria for seals, see page 71

15	For mineral oil HL, HLP and HFA	
	Standard seal system	M
	Standard seal system with guide rings	L
	Reduced friction, heavy industry	R
	For mineral oil HL, HLP, HFA and water glycol HFC	
	Standard seal system HFC	G ⁴⁰⁾
	Servo quality / reduced friction	T
	Chevron seal kits	A
	For HDFR phosphate ester and HFDU polyol ester	
	Servo quality / reduced friction	S
	Standard seal system FKM	V ⁴⁰⁾
	Chevron seal kits	B ³⁹⁾

Option

16	Without additional options, do not fill fields for additional options	W
	Additional options, fill fields for additional options	Z

Ordering code series CDH1 (fields for additional options)

01	02	03	04	05	06	07	08
[]	[]	[]	[]	[]	[]	[]	[]

01	Without inductive proximity switches	W
	Inductive proximity switches without mating connector - separate order, see page 49	E 37)
02	Without additional guide rings	W
	Additional guide rings	F 10), 28)
03	Without measuring coupling	W
	Measuring coupling, on both sides	A
	Measuring coupling, on both sides, stainless steel version	E 38)
04	Standard grease nipples, DIN 71412 form A	W
	Spherical bearing, maintenance-free	A 14), 35)
	Flat type grease nipples, DIN 3404 form A	B
05	Without piston rod extension	W
	Specify the piston rod extension LY in the plain text in mm	Y
06	Priming class CP3	W
	Painting class CP4	B 21)
	Painting class CP5	L 21)
	Painting class CP6	U 21)
	Painting class CP7	E 21)
07	Without oil filling	W
	With corrosion protection oil VG 68	F
08	Without test certificate	W
	With certificate of compliance 2.1 based on EN 10204	B
	With acceptance test certificate 3.1 based on EN 10204	C

Order examples:

Without additional options: CDH1MP5/100/56/300A3X/B11CADMW

With additional options: CDH1MP5/100/56/300A3X/B11CADMZEWABWWWW

- | | |
|--|--|
| <ul style="list-style-type: none"> 1) Only piston Ø 40 to 200 mm 2) Trunnion position freely selectable. When ordering, always specify the "XV" dimensions in the plain text in mm 3) Observe the max. available stroke length page 14 and admissible stroke length (acc. to buckling calculation) page 65 to 67 4) Not possible with MF4 5) Piston Ø 40 to 80 mm, only position 11, subplates only possible in combination with line connection "B" at the head 6) Piston Ø 63 to 200 mm, only position 11, subplates only possible in combination with line connection "B" at the head 7) Piston Ø 125 to 200 mm, only position 11, subplates only possible in combination with line connection "B" at the head 8) Piston Ø 160 to 200 mm, only position 11, subplates only possible in combination with line connection "B" at the head 9) Only piston Ø 80 to 320 mm 10) Seal designs A, B not possible;
Piston Ø 220 to 320 mm standard | <ul style="list-style-type: none"> 12) Only piston rod Ø 22 to 140 mm 13) Not with piston Ø 320 mm 14) Not possible with plain clevis "N" 15) Subplates for SL and SV valves (check valves)
Please note: Seal designs T, G, L, R, S and V are not designed for static hold function! 19) From piston Ø 63 mm 21) Specify RAL color in the plain text 28) Standard with seal design "L" 30) All graphical pictures in the data sheet show position 1 31) With MS2, only position 11 is possible 34) With MF4 and line connection B, M or C not possible 35) Not possible with MP3 37) Min. stroke length = 20 mm 38) On request 39) Not with piston rod Ø 22 mm 40) Not with piston rod Ø 220 mm |
|--|--|

Ordering code series CGH1

01	02	03	04	05	06	07	08	09	10	11	12	13	14	15	16
CG	H1		/		/		/		A	3X	/				

01	Double-rod cylinder	CG ¹⁸⁾
----	---------------------	--------------------------

02	Series	H1
----	--------	-----------

Types of mounting

03	Round flange at head	MF3
	Trunnion mounting	MT4 ²⁾
	Foot mounting	MS2

04	Piston Ø (ØAL) 40 ... 320 mm	
----	-------------------------------------	--

05	Piston rod Ø (ØMM) 22 ... 220 mm	
----	---	--

06	Stroke length in mm ³⁾	
----	-----------------------------------	--

07	Design principle: Head and base flanged	A
----	---	----------

08	Component series 30 ... 39 (30 ... 39: unchanged installation and connection dimensions)	3X
----	--	-----------

Line connection / version

09	According to ISO 1179-1 (pipe thread ISO 228-1)	B
	According to ISO 9974-1 (metric thread ISO 261)	M
	Flange hole pattern according to ISO 6162-2 tab. 2 type 1 (≠SAE 6000 PSI)	D ⁹⁾
	Flange hole pattern according to ISO 6164 tab. 2	H
	According to ISO 1179-1 (pipe thread ISO 228-1) with flat pipe flange	C ³¹⁾
	With mounted control block	Y ³⁸⁾

Line connection / position at head

10	View to piston rod ³⁰⁾		1
			2
			3
			4

Line connection/position at base

11	View to piston rod ³⁰⁾		1
			2
			3
			4

Ordering code series CGH1

01	02	03	04	05	06	07	08	09	10	11	12	13	14	15	16
CG	H1		/		/		/		A	3X	/				

Piston rod design

12	Hard chromium-plated	C
	Hardened and hard chromium-plated	H ¹²⁾

Piston rod end

13	Thread for swivel head CGAS	A
	Thread for swivel head CGA, CGAK, plain clevis CSA	G ¹³⁾
	With mounted swivel head CGAS	S ¹⁷⁾
	With mounted swivel head CGA	L ^{13), 17)}
	With mounted swivel head CGAK	M ^{13), 17)}
	With mounted plain clevis CSA	N ^{1), 17)}

End position cushioning

14	Without	U
	Both sides, self-adjusting	D ¹⁾
	Both sides, adjustable	E

Seal design - observe selection criteria for seals, see page 71

15	For mineral oil HL, HLP and HFA	
	Standard seal system	M
	Standard seal system with guide rings	L
	Reduced friction, heavy industry	R
	For mineral oil HL, HLP, HFA and water glycol HFC	
	Standard seal system HFC	G ⁴⁰⁾
	Servo quality / reduced friction	T
	Chevron seal kits	A
	For HDFR phosphate ester and HF DU polyol ester	
	Servo quality / reduced friction	S
	Standard seal system FKM	V ⁴⁰⁾
	Chevron seal kits	B ³⁹⁾

Option

16	Without additional options, do not fill fields for additional options	W
	Additional options, fill fields for additional options	Z

Ordering code series CGH1 (fields for additional options)

01	02	03	04	05	06	07	08
[]	[]	[]	[]	[]	[]	[]	[]

01	Without inductive proximity switches	W
	Inductive proximity switches without mating connector - separate order, see page 49	E ³⁷⁾
02	Without additional guide rings	W
	Additional guide rings	F ^{10), 28)}
03	Without measuring coupling	W
	Measuring coupling, on both sides	A
	Measuring coupling, on both sides, stainless steel version	E ³⁸⁾
04	Standard grease nipples, DIN 71412 form A	W
	Spherical bearing, maintenance-free	A ¹⁴⁾
	Flat type grease nipples, DIN 3404 form A	B
05	Without piston rod extension	W
	Specify the piston rod extension LY in the plain text in mm	Y ¹⁶⁾
06	Priming class CP3	W
	Painting class CP4	B ²¹⁾
	Painting class CP5	L ²¹⁾
	Painting class CP6	U ²¹⁾
	Painting class CP7	E ²¹⁾
07	Without oil filling	W
	With corrosion protection oil VG 68	F
08	Without test certificate	W
	With certificate of compliance 2.1 based on EN 10204	B
	With acceptance test certificate 3.1 based on EN 10204	C

Order examples:

Without additional options: CGH1MF3/100/56/300A3X/B11CADMW

With additional options: CGH1MF3/100/56/300A3X/B11CADMZEWABWWWW

- 1) Only piston Ø 40 to 200 mm
- 2) Trunnion position freely selectable. When ordering, always specify the "XV" dimensions in the plain text in mm
- 3) Observe the max. available stroke length page 14 and admissible stroke length (acc. to buckling calculation) page 65 to 67
- 9) Only piston Ø 80 to 320 mm
- 10) Seal designs A, B not possible;
Piston Ø 220 to 320 mm standard
- 12) Only piston rod Ø 22 to 140 mm
- 13) Not with piston Ø 320 mm
- 14) Not possible with plain clevis "N"
- 16) Only at left piston rod side (orientation: catalog figures)

- 17) Only one swivel head / plain clevis mounted, left piston rod side (orientation: catalog figures)
- 18) Not standardized
- 21) Specify RAL color in the plain text
- 28) Standard with seal design "L"
- 30) All graphical pictures in the data sheet show position 1
- 31) With MS2, only position 11 is possible
- 37) Min. stroke length = 20 mm
- 38) On request
- 39) Not with piston rod Ø 22 mm
- 40) Not with piston rod Ø 220 mm

Ordering code series CSH1

01	02	03	04	05	06	07	08	09	10	11	12	13	14	15	16
CS	H1		/		/		/	A	3X	/					

01	Differential cylinder with position measurement system	CS ¹⁸⁾
02	Series	H1

Types of mounting

03	Swivel eye at base	MP3 ¹⁾
	Self-aligning clevis at base	MP5
	Round flange at head	MF3
	Round flange at base	MF4
	Trunnion mounting	MT4 ²⁾
	Foot mounting	MS2

04	Piston \varnothing (\varnothing AL) 40 ... 320 mm	
05	Piston rod \varnothing (\varnothing MM) 28 ... 220 mm	
06	Stroke length in mm ³⁾	
07	Design principle: Head and base flanged	A
08	Component series 30 ... 39 (30 ... 39: unchanged installation and connection dimensions)	3X

Line connection / version

09	According to ISO 1179-1 (pipe thread ISO 228-1)	B
	According to ISO 9974-1 (metric thread ISO 261)	M
	Flange hole pattern according to ISO 6162-2 tab. 2 type 1 (\approx SAE 6000 PSI)	D ^{4); 9)}
	Flange hole pattern according to ISO 6164 tab. 2	H ⁴⁾
	According to ISO 1179-1 (pipe thread ISO 228-1) with flat pipe flange	C ³¹⁾
	With mounted control block	Y ³⁸⁾
	- For directional and control valves	
	Subplate NG6	P ^{4); 5)}
	Subplate NG10	T ^{4); 6)}
	Subplate NG16	U ^{4); 7)}
	Subplate NG25	V ^{4); 8)}
	- For SL and SV valves	
	Subplate NG6	A ^{4); 5); 15)}
	Subplate NG10	E ^{4); 6); 15)}
	Subplate NG20	L ^{4); 7); 15)}
Subplate NG30	N ^{4); 8); 15)}	

Line connection / position at head

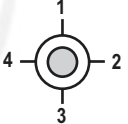
10	View to piston rod ³⁰⁾		1
			2
			3
			4

Line connection/position at base

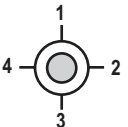
11	View to piston rod ³⁰⁾		1
			2 ³⁴⁾
			3
			4 ³⁴⁾

Ordering code series CSH1

01	02	03	04	05	06	07	08	09	10	11	12	13	14	15	16
CS	H1		/		/		/		A	3X	/				Z

Piston rod design

12	Hard chromium-plated	C
	Hardened and hard chromium-plated	H ¹⁹⁾

Piston rod end

13	Thread for swivel head CGAS	A
	Thread for swivel head CGA, CGAK, plain clevis CSA	G ¹³⁾
	With mounted swivel head CGAS	S
	With mounted swivel head CGA	L ¹³⁾
	With mounted swivel head CGAK	M ¹³⁾
	With mounted plain clevis CSA	N ¹⁾

End position cushioning

14	Without	U
	Both sides, adjustable	E ²⁰⁾

Seal design - observe selection criteria for seals, see page 71

15	For mineral oil HL, HLP and HFA	
	Standard seal system	M ²⁹⁾
	Standard seal system with guide rings	L
	Reduced friction, heavy industry	R ²⁹⁾
	For mineral oil HL, HLP, HFA and water glycol HFC	
	Standard seal system HFC	G ^{29; 41)}
	Servo quality / reduced friction	T ²⁹⁾
	For HDFR phosphate ester and HFDU polyol ester	
	Servo quality / reduced friction	S ²⁹⁾
	Standard seal system FKM	V ^{29; 41)}

Option

16	Additional options, fill fields for additional options	Z
----	---	----------

Ordering code series CSH1 (fields for additional options)

[-]	[T]	[Z]							
	T								

01	Position measurement system (magnetostrictive) without mating connector - separate order, see page 53, 55, 56 and 58	T
02	Analog output 4 ... 20 mA	C
	Analog output 0 ... 10 V	F
	Digital output SSI (resolution 5 µm, asynchronous forward)	D
	Digital output SSI (resolution 1 µm, synchronous forward)	S
	Profibus D63 (integrated supply)	N
	Profibus D53 (separate supply line)	P
	IO-Link	L ^{39); 40)}
	Profinet RT and IRT with encoder profile	R
03	Without measuring coupling	W
	Measuring coupling, on both sides	A
	Measuring coupling, on both sides, stainless steel version	E ³⁸⁾
04	Standard grease nipples, DIN 71412 form A	W
	Spherical bearing, maintenance-free	A ^{14); 35)}
	Flat type grease nipples, DIN 3404 form A	B
05	Without piston rod extension	W
	Specify the piston rod extension LY in the plain text in mm	Y
06	Priming class CP3	W
	Painting class CP4	B ²¹⁾
	Painting class CP5	L ²¹⁾
	Painting class CP6	U ²¹⁾
	Painting class CP7	E ²¹⁾
07	Without oil filling	W
	With corrosion protection oil VG 68	F
08	Without test certificate	W
	With certificate of compliance 2.1 based on EN 10204	B
	With acceptance test certificate 3.1 based on EN 10204	C

Order examples:

With additional options: CSH1MP5/100/56/300A3X/T11CAEMZTCAWWWWW

- | | |
|---|--|
| <ul style="list-style-type: none"> 1) Only piston Ø 40 to 200 mm 2) Trunnion position freely selectable. When ordering, always specify the "XV" dimensions in the plain text in mm 3) Observe the max. available stroke length page 14 and admissible stroke length (acc. to buckling calculation) page 65 to 67 4) Not possible with MF4 5) Piston Ø 40 to 80 mm, only position 11, subplates only possible in combination with line connection "B" at the head 6) Piston Ø 63 to 200 mm, only position 11, subplates only possible in combination with line connection "B" at the head 7) Piston Ø 125 to 200 mm, only position 11, subplates only possible in combination with line connection "B" at the head 8) Piston Ø 160 to 200 mm, only position 11, subplates only possible in combination with line connection "B" at the head 9) Only piston Ø 80 to 320 mm 13) Not with piston Ø 320 mm 14) Not possible with plain clevis "N" | <ul style="list-style-type: none"> 15) Subplates for SL and SV valves (check valves)
Please note: Seal designs T, G, L, R, S and V are not designed for static hold function! 18) Not standardized 19) Only piston rod Ø 28 to 140 mm 20) Possible from piston rod Ø 45 mm 21) Specify RAL color in the plain text 29) With CSH, by default with guide rings 30) All graphical pictures in the data sheet show position 1 31) With MS2, only position 11 is possible 34) With MF4 and line connection B, M or C not possible 35) Not possible with MP3 38) On request 39) Not possible with MP3 and MP5 40) Observe min. stroke length 50 mm / max. stroke length 2540 mm 41) Not with piston rod Ø 220 mm |
|---|--|

Technical data

(For applications outside these values, please consult us!)

Standards:

standard; main dimensions like piston
 \varnothing and piston rod \varnothing correspond to ISO 3320.

Nominal pressure: 250 bar

Static test pressure: 375 bar

Reduced test pressure 315 bar

The maximum operating pressures must be less than or equal to the applicable nominal pressures and apply to applications with shock-free operation with reference to excess pressure and/or external loads. With extreme loads like e.g. high cycle sequence, mounting elements and threaded piston rod connections must be designed for durability.

Minimum pressure:

Depending on the application, operating conditions and technical design, a certain minimum pressure

(approx. 10 bar)

is required in order to guarantee a technically perfect function of the hydraulic cylinder.

Installation position: arbitrary

Hydraulic fluid (additional data sheet):

Mineral oils DIN 51524 HL, HLP (90220)

Oil-in-water emulsion HFA (90223)

Water glycol HFC (90223)

Phosphate ester HFDR (90222)

Polyol ester HFDU (90222)

Hydraulic fluid temperature range: see page 71

Ambient temperature range: see page 71

Optimum viscosity range: 20 to 100 mm²/s

Minimum admissible viscosity: 12 mm²/s

Maximum admissible viscosity: 380 mm²/s

Cleanliness class acc. to ISO

Maximum admissible degree of contamination of the hydraulic fluid according to ISO 4406 (c) class 20/18/15.

The cleanliness classes specified for the components must be adhered to in hydraulic systems. Effective filtration prevents faults and simultaneously increases the life cycle of the components. For the selection of the filters

Bleeding by default secured against unscrewing

Color set-up:

Priming: By default, hydraulic cylinders are primed with a coating (color gentian blue RAL 5010) of min. 40 μ m, see page 83.

Other colors on request.

Following surfaces of cylinders and attached parts are not primed:

- All fitting diameters to the customer side
- Sealing surfaces for line connection
- Sealing surfaces for flange connection
- Connection surface for valve mounting
- Inductive proximity switches
- Position measurement system
- Measuring coupling
- Spherical / plain bearing
- Grease nipples

Painting: By default, hydraulic cylinders can be ordered in four corrosivity categories in the RAL colors, see page 83.

Following surfaces of cylinders and attached parts are not painted:

- All fitting diameters and connection surfaces to customer side
- Sealing surfaces for line connection
- Sealing surfaces for flange connection
- Connection surface for valve mounting
- Inductive proximity switches
- Position measurement system
- Measuring coupling
- Spherical / plain bearing
- Grease nipples

Surfaces not primed or painted are protected with solvent-free corrosion protection compound.

Accessories ordered as a separate order item are not primed or painted by default. Corresponding priming and/or painting on request.

Technical data

(For applications outside these values, please consult us!)

Stroke velocity:

Please observe the guideline on max. stroke velocities (with recommended flow velocity of 5 m/s in the line connection) in the table. Higher stroke velocity on request. If the extension velocity is considerably higher than the retraction velocity of the piston rod, drag-out losses of the medium may result. If necessary, please consult us.

Piston Ø (mm)	Line connection	Max. stroke velocity in m/s
40	G1/2	0.31
50	G1/2	0.20
63	G3/4	0.28
80	G3/4	0.18
100	G1	0.20
125	G1 1/4	0.20
140	G1 1/4	0.16
160	G1 1/2	0.18
180	G1 1/2	0.14
200	G1 1/2	0.11
220	G1 1/2	0.09
250	G1 1/2	0.07
280	G1 1/2	0.06
320	G1 1/2	0.04

Boundary and application conditions:

- ▶ The mechanical alignment of the movement axis and thus the mounting points of hydraulic cylinder and piston rod must be ensured. Lateral forces on the guides of piston rod and piston are to be avoided. It may be necessary to consider the own weight of the hydraulic cylinder (MP3 / MP5 or MT4) or the piston rod.
- ▶ The bending length/bending load of the piston rod and/or the hydraulic cylinder must be observed (see page topic Bucklig).
- ▶ The maximum admissible stroke velocities with regard to the suitability/load of seals must be observed as must their compatibility with the properties of the hydraulic fluid (see page topic Seals).
- ▶ The maximum admissible velocities/kinetic energies when moving into the end positions, also considering external loads, must be observed.
 Danger: Excess pressure
- ▶ The maximum admissible operating pressure must be complied with in any operating state of the hydraulic cylinder. Possible pressure intensification resulting from the area ratio of annulus area to piston area and possible throttling points are to be observed.
- ▶ Detrimental environmental influences, like e.g. aggressive finest particles, vapors, high temperatures, etc. as well as contaminations and deterioration of the hydraulic fluid are to be avoided.

Notice:

- ▶ This list does not claim to be complete. In case of questions regarding the compatibility with the medium or exceedance of the boundary or application conditions, please contact us.
- ▶ All graphical pictures in the data sheet are examples. The product supplied may therefore differ from the figure shown.

Technical data

(For applications outside these values, please consult us!)

Acceptance:

Every hydraulic cylinders is tested according to standards and following ISO 10100:2020 with module L.

Safety instructions:

For assembly, commissioning and maintenance of hydraulic cylinders, observe the operating instructions 07100-B! Service and repair work has to be performed by personnel especially trained for this purpose. No warranty is accepted for damage as a consequence of assembly

Check lists for hydraulic cylinders:

Cylinders the characteristics and/or application parameters of which deviate from the values specified in the data sheet can only be offered as a special version on request. For offers, the deviations of the characteristics and / or application parameters must be described in the check lists for hydraulic cylinders (07200).

Minimum strokes:

When using end position cushioning, the minimum stroke must also be observed, see page 68 "End position cushioning".

Project planning software ICS (Interactive Catalog System)

The ICS (Interactive Catalog System) is a selection and project planning aid for hydraulic cylinders. The ICS allows designers for machines and systems to quickly and reliably find the perfect hydraulic cylinder solution through logic-guided type key enquiries. This software helps to solve design and project planning tasks more quickly and efficiently. After having been guided through the product selection, the user quickly and reliably gets the exact technical data of the selected component as well as 3D CAD data in the correct file format for all common CAD systems. This allows users to reduce costs while increasing their competitiveness.

Technical data

(For applications outside these values, please consult us!)

Diameters, areas, forces, flow

Piston	Piston rod	Area ratio	Areas			Force at 250 bar ¹⁾			Flow at 0.1 m/s ²⁾			Max. available stroke length
			Piston	Rod	Ring	Pressure	Diff.	Pulling	Off	Diff.	On	
ØAL mm	ØMM mm	ϕ A_1/A_3	A_1 cm ²	A_2 cm ²	A_3 cm ²	F_1 kN	F_2 kN	F_3 kN	q_{V1} l/min	q_{V2} l/min	q_{V3} l/min	mm
40	22	1.43	12.56	3.80	8.76	31.40	9.50	21.90	7.5	2.3	5.3	2000
	28	1.96		6.16	6.40		15.40	16.00		3.7	3.8	
50	28	1.46	19.63	6.16	13.47	49.10	15.40	33.70	11.8	3.7	8.1	2000
	36	2.08		10.18	9.45		25.45	23.65		6.1	5.7	
63	36	1.48	31.17	10.18	20.99	77.90	25.45	52.45	18.7	6.1	12.6	2000
	45	2.04		15.90	15.27		39.75	38.15		9.5	9.2	
80	45	1.46	50.26	15.90	34.36	125.65	39.75	85.90	30.2	9.5	20.7	2000
	56	1.96		24.63	25.63		61.55	64.10		14.8	15.4	
100	56	1.46	78.54	24.63	53.91	196.35	61.55	134.80	47.1	14.8	32.3	3000
	70	1.96		38.48	40.06		96.20	100.15		23.1	24.0	
125	70	1.46	122.72	38.48	84.24	306.75	96.20	210.55	73.6	23.1	50.5	3000
	90	2.08		63.62	59.10		159.05	147.70		38.2	35.4	
140	90	1.70	153.94	63.62	90.32	384.75	159.05	225.70	92.4	38.2	54.2	3000
	100	2.04		78.54	75.40		196.35	188.40		47.1	45.3	
160	100	1.64	201.06	78.54	122.50	502.50	196.35	306.15	120.6	47.1	73.5	3000
	110	1.90		95.06	106.00		237.65	264.85		57.0	63.6	
180	110	1.60	254.47	95.06	159.43	636.17	237.65	398.52	152.7	57.0	95.7	3000
	125	1.93		122.72	131.75		306.80	329.37		73.6	79.1	
200	125	1.64	314.16	122.72	191.44	785.25	306.80	478.45	188.5	73.6	114.9	3000
	140	1.96		153.96	160.20		384.90	400.35		92.4	96.1	
220	140	1.68	380.1	153.9	226.2	950.3	384.8	565.5	228.1	92.4	135.7	6000
	160	2.12		201.0	179.1		502.6	447.7		120.7	107.4	
250	160	1.69	490.8	201.0	289.8	1227.2	502.7	724.5	294.5	120.7	173.8	6000
	180	2.08		254.4	236.4		636.2	591.0		152.7	141.8	
280	180	1.70	615.7	254.4	361.3	1539.4	636.2	903.2	369.4	152.7	216.7	6000
	200	2.04		314.1	301.6		785.4	753.9		188.5	180.9	
320	200	1.64	804.2	314.1	490.1	2010.6	785.4	1225.2	482.5	188.5	294.0	6000
	220	1.90		380.1	424.2		950.3	1060.3		228.1	254.4	

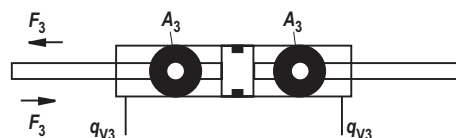
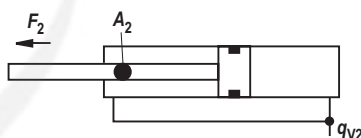
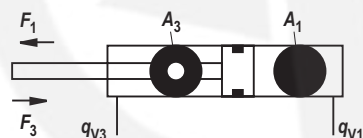

1) Theoretical static cylinder force
 (without consideration of the efficiency and admissible load for attachment parts such as swivel heads, plates, or valves, etc.)

2) Stroke velocity

Technical data

(For applications outside these values, please consult us!)

Tolerances according to DIN ISO 6022

Installation dimensions	WC	XC ²⁾	XO ²⁾	XS ^{1; 2)}	XV ²⁾	ZP ²⁾	Stroke tolerances ³⁾
Type of mounting	MF3	MP3	MP5	MS2	MT4	MF4	
Stroke length	Tolerances						
≤ 1250	±2	±1.5	±1.5	±2	±2	±1.5	+2
> 1250 – ≤ 3150	±4	±3	±3	±4	±4	±3	+5
> 3150 – ≤ 6000	±8	±5	±5	±8	±8	±5	+8

¹⁾ Not standardized

²⁾ Including stroke length

³⁾ Stroke tolerances must not be added to the tolerances listed in this table.

Overview types of mounting: Series CDH1 / CGH1

CDH1 MP3; see page 18, 19



CDH1 MP5; see page 20, 21



CDH1 MF3; see page 22, 23



CGH1 MF3; see page 22, 23



CDH1 MF4; see page 24, 25



CDH1 MT4; see page 26, 27



CGH1 MT4; see page 26, 27



CDH1 MS2; see page 28, 29



CGH1 MS2; see page 28, 29



Overview types of mounting: Series CSH1

CSH1 MP3

see page 30, 31



CSH1 MF4

see page 36, 37



CSH1 MP5

see page 32, 33



CSH1 MT4

see page 38, 39



CSH1 MF3

see page 34, 35



CSH1 MS2

see page 40, 41



Dimensions

Swivel eye at base CDH1: MP3 (dimensions in mm)

CDH1 MP3; ØAL 40 - 200 mm

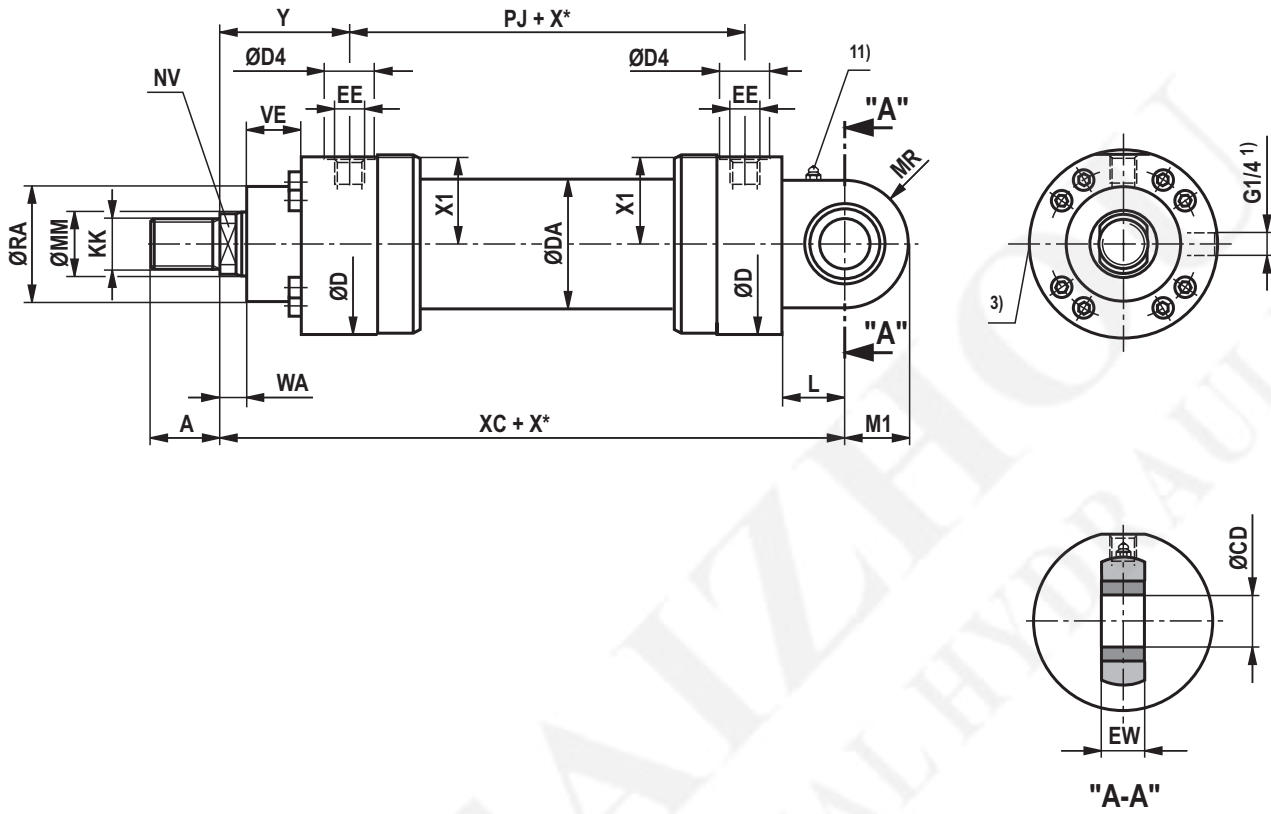

CDH1 MP3: with seal design "A", "B" and ØAL 160 - 200 mm

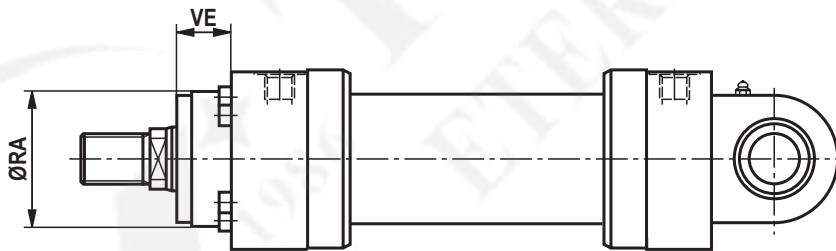

Dimensions

Swivel eye at base CDH1: MP3 (dimensions in mm)

ØAL	ØMM	KK 5)	A 5)	KK 6)	A 6)	NV	ØD	ØDA	ØD4 2)	EE 4; 16)	EE 4; 17)	Y	PJ
40	22/28	M16x1,5	16	M18x2	30	16/22	88	52	34	G1/2	M22x1,5	79	120
50	28/36	M22x1,5	22	M24x2	35	22/30	102	62	34	G1/2	M22x1,5	87	120
63	36/45	M28x1,5	28	M30x2	45	30/36	120	78	42	G3/4	M27x2	100	133
80	45/56	M35x1,5	35	M39x3	55	36/46	140	95	42	G3/4	M27x2	104	146
100	56/70	M45x1,5	45	M50x3	75	46/60	170	125	47	G1	M33x2	124	171
125	70/90	M58x1,5	58	M64x3	95	60/75	206	150	58	G1 1/4	M42x2	135	205
140	90/100	M65x1,5	65	M80x3	110	75/85	226	170	58	G1 1/4	M42x2	156	219
160	100/110	M80x2	80	M90x3	120	85/95	265	190	65	G1 1/2	M48x2	185	240
180	110/125	M100x2	100	M100x3	140	95/110	292	210	65	G1 1/2	M48x2	199	264
200	125/140	M110x2	110	M110x4	150	110/120	310	235	65	G1 1/2	M48x2	205	278

ØAL	ØMM	X1	WA	XC	L	MR	M1	ØCD H11	EW -0.4	ØRA 7)	VE 7)	ØRA 8)	VE 8)
40	22/28	41	14	252	32.5	31	28	25	23	52	40	52	20
50	28/36	48.5	18	265	37.5	36	32.5	30	28	65	40	65	16
63	36/45	56.5	22	302	45	42	40	35	30	75	45	75	17
80	45/56	67	20	330	50	52	50	40	35	95	45	95	13
100	56/70	82	30	385	60	65	62.5	50	40	115	55	115	20
125	70/90	99	32	447	70	70	70	60	50	135	60	135	17
140	90/100	109.5	35	490	75	82	82	70	55	155	70	155	22
160	100/110	129	40	550	85	95	95	80	60	200	80	200	80
180	110/125	142.5	40	610	90	113	113	90	65	220	90	220	90
200	125/140	152	40	645	115	125	125	100	70	235	95	235	95

ØAL = piston Ø
ØMM = piston rod Ø
X* = stroke length

- 1) Bleeding: With view to the piston rod, the position is offset by 90° in relation to the line connection (clockwise)
- 2) Ø D4 max. 0.5 mm deep
- 3) Throttle valve only with end position cushioning "E" (180° for bleeding)
- 4) Flange connections see separate table pages 42 and 43
- 5) Thread design "G"
- 6) Thread design "A"

7) Dimensions for cylinders with seal design M, T, G, L, R, S and V

8) Dimensions for cylinders with seal design A and B

11) Standard version "W"

Grease nipple, cone head form A according to DIN 71412

16) Line connection "B" and "C"

17) Line connection "M"

Dimensions

Self-aligning clevis at base CDH1: MP5 (dimensions in mm)

CDH1 MP5

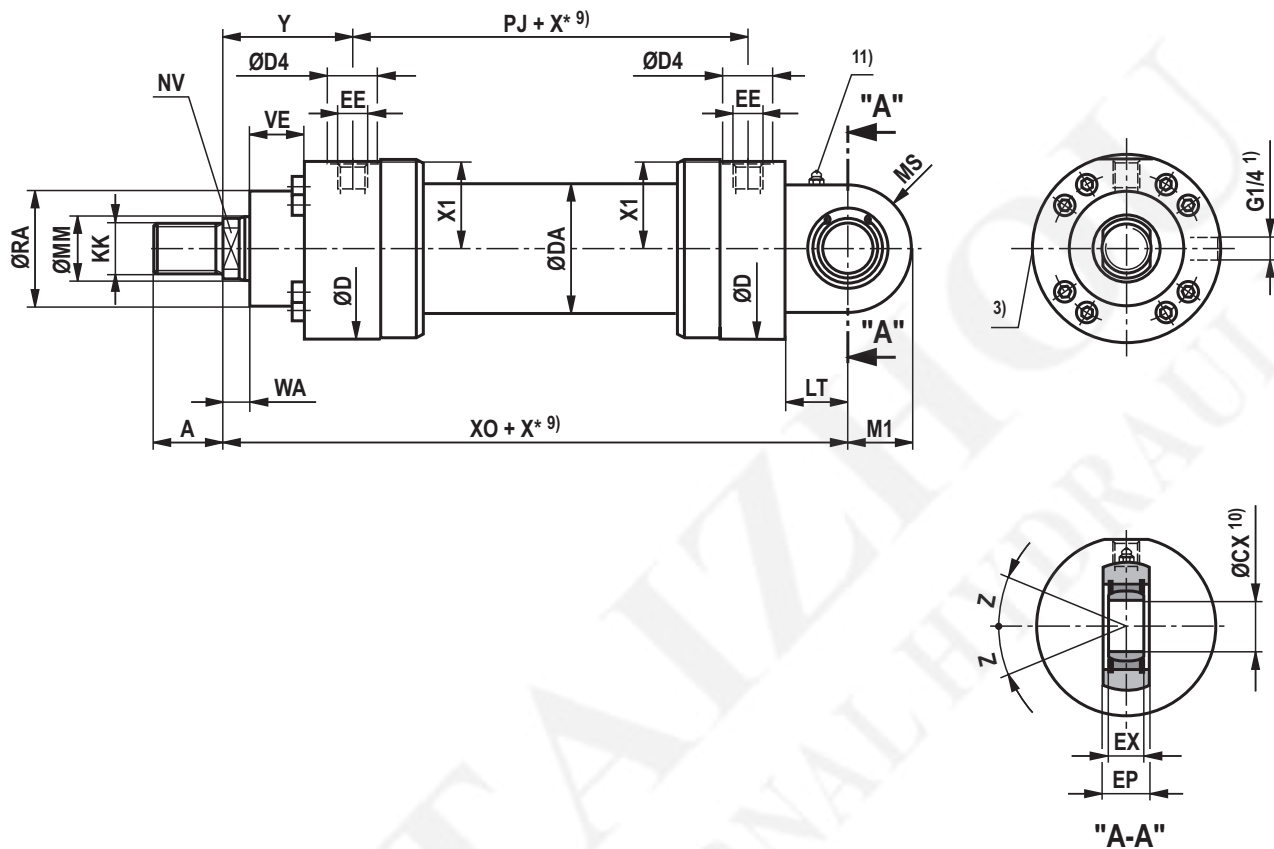

CDH1 MP5: with seal design "A", "B" and $\text{ØAL} 160 - 320 \text{ mm}$

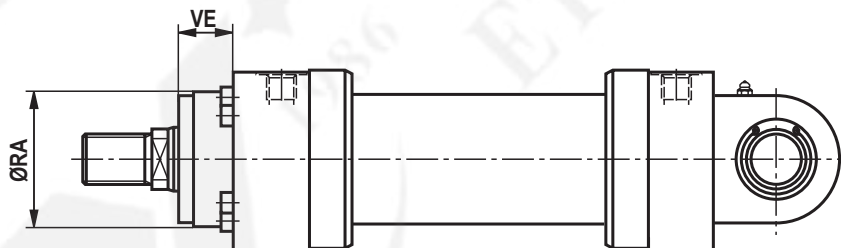

Dimensions

Self-aligning clevis at base CDH1: MP5 (dimensions in mm)

ØAL	ØMM	KK 5)	A 5)	KK 6)	A 6)	NV	ØD	ØDA	ØD4 2)	EE 4; 16)	EE 4; 17)	Y	PJ	X1	C ₀ ¹⁸⁾ kN
40	22/28	M16x1,5	16	M18x2	30	16/22	88	52	34	G1/2	M22x1,5	79	120	41	72
50	28/36	M22x1,5	22	M24x2	35	22/30	102	62	34	G1/2	M22x1,5	87	120	48.5	106
63	36/45	M28x1,5	28	M30x2	45	30/36	120	78	42	G3/4	M27x2	100	133	56.5	153
80	45/56	M35x1,5	35	M39x3	55	36/46	140	95	42	G3/4	M27x2	104	146	67	250
100	56/70	M45x1,5	45	M50x3	75	46/60	170	125	47	G1	M33x2	124	171	82	365
125	70/90	M58x1,5	58	M64x3	95	60/75	206	150	58	G1 1/4	M42x2	135	205	99	400
140	90/100	M65x1,5	65	M80x3	110	75/85	226	170	58	G1 1/4	M42x2	156	219	109.5	540
160	100/110	M80x2	80	M90x3	120	85/95	265	190	65	G1 1/2	M48x2	185	240	129	670
180	110/125	M100x2	100	M100x3	140	95/110	292	210	65	G1 1/2	M48x2	199	264	142.5	980
200	125/140	M110x2	110	M110x4	150	110/120	310	235	65	G1 1/2	M48x2	205	278	152	1120
220	140/160	M120x3	120	M120x4	160	120/140	355	273	65	G1 1/2	M48x2	242	326	174	1700
250	160/180	M120x3	120	M120x4	160	140/160	395	305	65	G1 1/2	M48x2	266	326	194	1700
280	180/200	M130x3	130	M150x4	190	160/180	425	343	65	G1 1/2	M48x2	282	375	210	2900
320	200/220	-	-	M160x4	200	180/200	490	394	65	G1 1/2	M48x2	287	431	242	-

ØAL	ØMM	F _{adm} ¹⁹⁾ kN	WA	XO	X* min	LT	M1	MS	ØCX	EP -0.4	EX	Z	ØRA 7)	VE 7)	ØRA 8)	VE 8)
40	22/28	25.9	14	252	-	32.5	28	31	25 _{-0.010}	23	20 _{-0.12}	7 °	52	40	52	20
50	28/36	38.2	18	265	-	37.5	32.5	36	30 _{-0.010}	28	22 _{-0.12}	6 °	65	40	65	16
63	36/45	55.1	22	302	-	45	40	42	35 _{-0.012}	30	25 _{-0.12}	6 °	75	45	75	17
80	45/56	90.0	20	330	-	50	50	52	40 _{-0.012}	35	28 _{-0.12}	7 °	95	45	95	13
100	56/70	131.4	30	385	-	60	62.5	65	50 _{-0.012}	40	35 _{-0.12}	6 °	115	55	115	20
125	70/90	144.0	32	447	-	70	70	70	60 _{-0.015}	50	44 _{-0.15}	6 °	135	60	135	17
140	90/100	194.4	35	490	-	75	82	82	70 _{-0.015}	55	49 _{-0.15}	6 °	155	70	155	22
160	100/110	241.2	40	550	-	85	95	95	80 _{-0.015}	60	55 _{-0.15}	6 °	200	80	200	80
180	110/125	352.8	40	610	-	90	113	113	90 _{-0.020}	65	60 _{-0.20}	5 °	220	90	220	90
200	125/140	403.2	40	645	-	115	125	125	100 _{-0.020}	70	70 _{-0.20}	7 °	235	95	235	95
220	140/160	612.0	40	750	-	125	150 ¹²⁾	140 ¹²⁾	110 _{-0.020}	80	70 _{-0.20}	6 °	270	115	270	115
250	160/180	612.0	40	789	-	140	168 ¹²⁾	158 ¹²⁾	110 _{-0.020}	80	70 _{-0.20}	6 °	300	125	300	125
280	180/200	1044.0	40	884	31	150	188 ¹²⁾	178 ¹²⁾	120 _{-0.020}	90	85 _{-0.20}	6 °	325	130	325	130
320	200/220	-	40	980	-	175	210 ¹²⁾	200 ¹²⁾	140 _{-0.020}	110	90 _{-0.20}	7 °	365	155	365	155

ØAL = piston Ø

ØMM = piston rod Ø

X* = stroke length

X*min = min. stroke length

With hydraulic cylinders with end position cushioning, observe the notice on page 68!

1) Bleeding: With view to the piston rod, the position is offset by 90° in relation to the line connection (clockwise)

2) Ø D4 max. 0.5 mm deep

3) Throttle valve only with end position cushioning "E" (180° for bleeding)

4) Flange connections see separate table pages 42 and 43

5) Thread design "G"

6) Thread design "A"

7) Dimensions for cylinders with seal design M, T, G, L, R, S and V

8) Dimensions for cylinders with seal design A and B

9) Observe the min. stroke length "X*min"

10) Related bolt Ø m6;

Related bolt Ø j6 for maintenance-free spherical bearing

11) Standard version "W"

Grease nipple, cone head form A according to DIN 71412; not applicable to spherical bearing, maintenance-free "A"

12) The specified dimensions are maximum values, tolerance classes 342 according to ISO 9013 Thermal cutting

16) Line connection "B" and "C"

17) Line connection "M"

18) C₀ = static load rating of the swivel head

19) F_{adm} = max. admissible load of the swivel head with oscillatory or alternating loads

Dimensions

Round flange at head CDH1/CGH1: MF3 (dimensions in mm)

CDH1 MF3

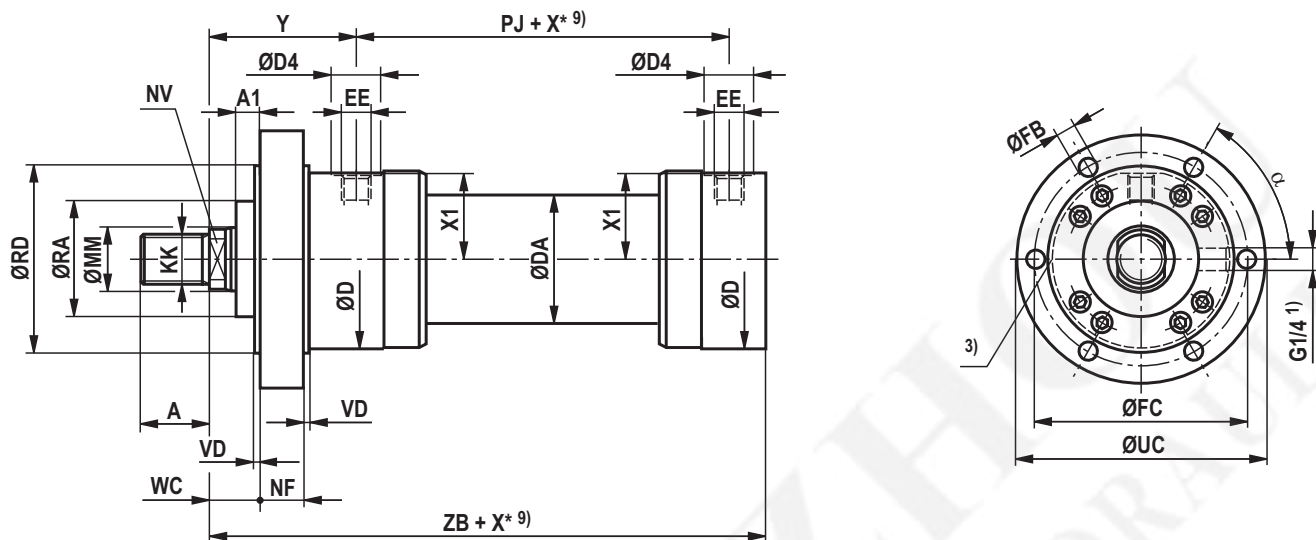

CGH1 MF3

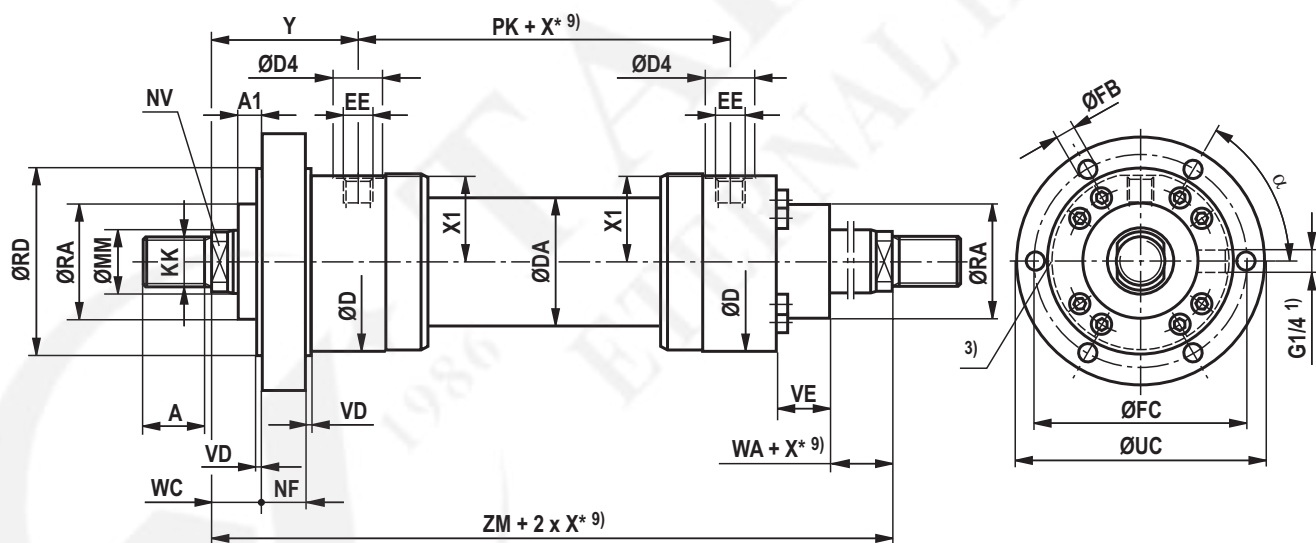

CGH1 MF3: with seal design "A", "B" and ØAL 160 - 320 mm

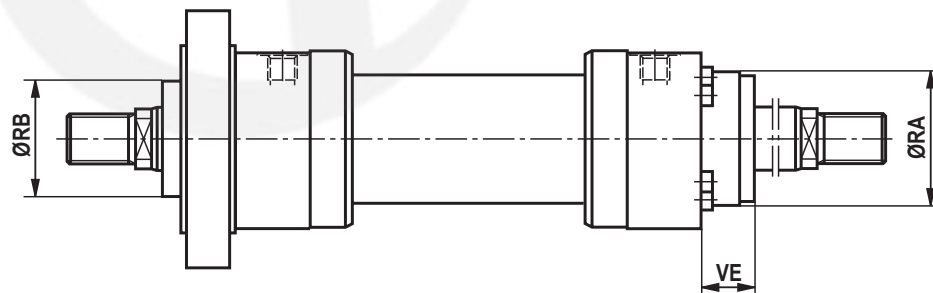

Dimensions

Round flange at head CDH1/CGH1: MF3 (dimensions in mm)

ØAL	ØMM	KK 5)	A 5)	KK 6)	A 6)	NV	ØD	ØDA	ØD4 2)	EE 4; 16)	EE 4; 17)	Y	PJ	X1
40	22/28	M16x1,5	16	M18x2	30	16/22	88	52	34	G1/2	M22x1,5	79	120	41
50	28/36	M22x1,5	22	M24x2	35	22/30	102	62	34	G1/2	M22x1,5	87	120	48.5
63	36/45	M28x1,5	28	M30x2	45	30/36	120	78	42	G3/4	M27x2	100	133	56.5
80	45/56	M35x1,5	35	M39x3	55	36/46	140	95	42	G3/4	M27x2	104	146	67
100	56/70	M45x1,5	45	M50x3	75	46/60	170	125	47	G1	M33x2	124	171	82
125	70/90	M58x1,5	58	M64x3	95	60/75	206	150	58	G1 1/4	M42x2	135	205	99
140	90/100	M65x1,5	65	M80x3	110	75/85	226	170	58	G1 1/4	M42x2	156	219	109.5
160	100/110	M80x2	80	M90x3	120	85/95	265	190	65	G1 1/2	M48x2	185	240	129
180	110/125	M100x2	100	M100x3	140	95/110	292	210	65	G1 1/2	M48x2	199	264	142.5
200	125/140	M110x2	110	M110x4	150	110/120	310	235	65	G1 1/2	M48x2	205	278	152
220	140/160	M120x3	120	M120x4	160	120/140	355	273	65	G1 1/2	M48x2	242	326	174
250	160/180	M120x3	120	M120x4	160	140/160	395	305	65	G1 1/2	M48x2	266	326	194
280	180/200	M130x3	130	M150x4	190	160/180	425	343	65	G1 1/2	M48x2	282	375	210
320	200/220	-	-	M160x4	200	180/200	490	394	65	G1 1/2	M48x2	287	431	243

ØAL	ØMM	ØRD e8	WC	VD	NF	PK	A1	ZB	ZM	X* min	ØFB H13	ØFC js13	ØUC -1	α	WA	ØRA 7)	VE 7)	ØRA 8)	VE 8)	ØRB 8) max
40	22/28	90	19	5	30	120	0	226	278	-	9	108	130	60 °	14	52	40	52	20	-
50	28/36	110	23	5	30	120	0	233	294	-	11	130	160	60 °	18	65	40	65	16	-
63	36/45	130	27	5	35	133	0	262	333	-	13.5	155	185	60 °	22	75	45	75	17	-
80	45/56	145	25	5	35	146	0	280	354	-	13.5	170	200	60 °	20	95	45	95	13	-
100	56/70	175	35	5	45	171	0	330	419	-	17.5	205	245	60 °	30	115	55	115	20	-
125	70/90	210	37	5	50	205	0	382	475	-	22	245	295	60 °	32	135	60	135	17	-
140	90/100	230	45	10	50	219	0	420	531	-	22	265	315	60 °	35	155	70	155	22	-
160	100/110	275	50	10	60	240	0	475	610	-	30	325	385	60 °	40	200	80	200	80	-
180	110/125	300	50	10	70	264	0	515	662	-	30	360	420	60 °	40	220	90	220	90	-
200	125/140	320	50	10	75	278	0	535	688	-	33	375	445	60 °	40	235	95	235	95	-
220	140/160	370	60	10	85	326	20	635	810	-	33	430	490	60 °	40	270	115	270	115	270
250	160/180	415	70	10	85	326	30	659	858	-	39	485	555	60 °	40	300	125	300	125	300
280	180/200	450	65	10	95	375	25	744	939	31	39	520	590	60 °	40	325	130	325	130	325
320	200/220	510	65	10	120	431	25	815	1005	-	45	600	680	60 °	40	365	155	365	155	365

ØAL = piston Ø

ØMM = piston rod Ø

X* = stroke length

X*min = min. stroke length

With hydraulic cylinders with end position cushioning,
observe the notice on page 68!

1) Bleeding: With view to the piston rod, the position is offset by 90°
in relation to the line connection (clockwise)

2) Ø D4 max. 0.5 mm deep

3) Throttle valve only with end position cushioning "E"
(180° for bleeding)

4) Flange connections see separate table pages 42 and 43

5) Thread design "G"

6) Thread design "A"

7) Dimensions for cylinders with seal design M, T, G, L, R, S and V

8) Dimensions for cylinders with seal design A and B

9) Observe the min. stroke length "X*min"

16) Line connection "B" and "C"

17) Line connection "M"

Dimensions

Round flange at base CDH1: MF4 (dimensions in mm)

CDH1 MF4

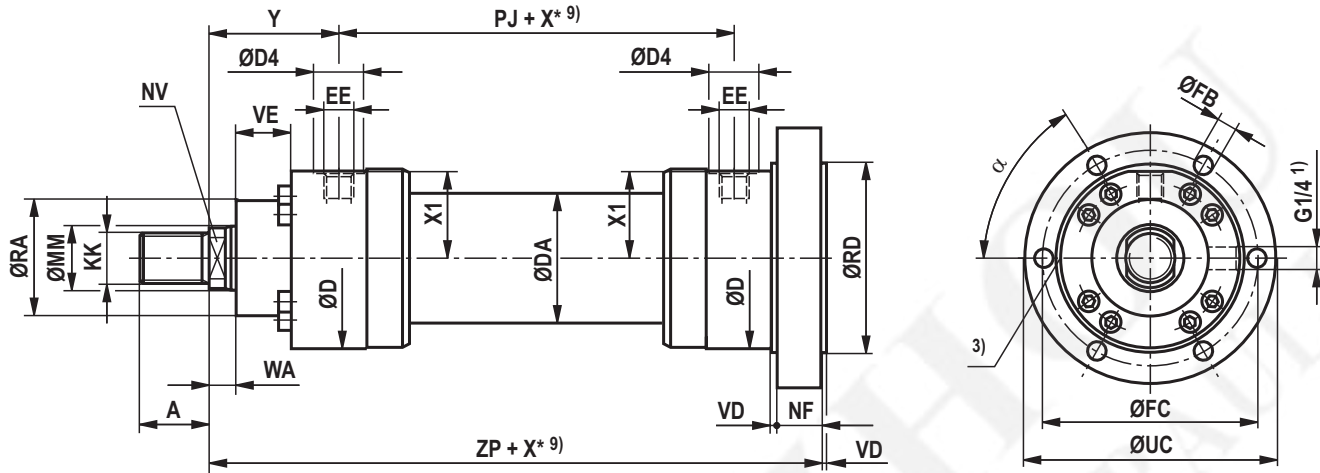

CDH1 MF4: with seal design "A", "B" and ØAL 160 - 320 mm

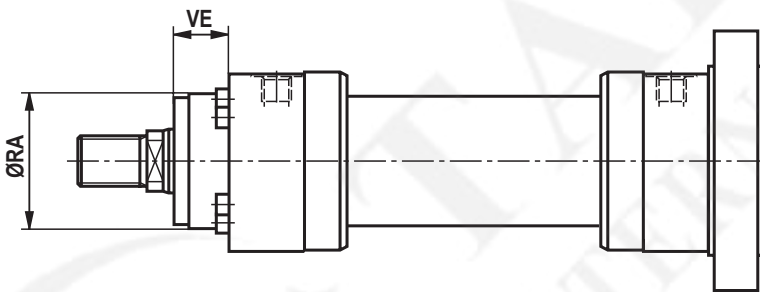

Dimensions

Round flange at base CDH1: MF4 (dimensions in mm)

ØAL	ØMM	KK 5)	A 5)	KK 6)	A 6)	NV	ØD	ØDA	ØD4 2)	EE 4; 16)	EE 4; 17)	Y	PJ	X1
40	22/28	M16x1,5	16	M18x2	30	16/22	88	52	34	G1/2	M22x1,5	79	120	41
50	28/36	M22x1,5	22	M24x2	35	22/30	102	62	34	G1/2	M22x1,5	87	120	48.5
63	36/45	M28x1,5	28	M30x2	45	30/36	120	78	42	G3/4	M27x2	100	133	56.5
80	45/56	M35x1,5	35	M39x3	55	36/46	140	95	42	G3/4	M27x2	104	146	67
100	56/70	M45x1,5	45	M50x3	75	46/60	170	125	47	G1	M33x2	124	171	82
125	70/90	M58x1,5	58	M64x3	95	60/75	206	150	58	G1 1/4	M42x2	135	205	99
140	90/100	M65x1,5	65	M80x3	110	75/85	226	170	58	G1 1/4	M42x2	156	219	109.5
160	100/110	M80x2	80	M90x3	120	85/95	265	190	65	G1 1/2	M48x2	185	240	129
180	110/125	M100x2	100	M100x3	140	95/110	292	210	65	G1 1/2	M48x2	199	264	142.5
200	125/140	M110x2	110	M110x4	150	110/120	310	235	65	G1 1/2	M48x2	205	278	152
220	140/160	M120x3	120	M120x4	160	120/140	355	273	65	G1 1/2	M48x2	242	326	174
250	160/180	M120x3	120	M120x4	160	140/160	395	305	65	G1 1/2	M48x2	266	326	194
280	180/200	M130x3	130	M150x4	190	160/180	425	343	65	G1 1/2	M48x2	282	375	210
320	200/220	-	-	M160x4	200	180/200	490	394	65	G1 1/2	M48x2	287	431	243

ØAL	ØMM	WA	ZP	X* min	NF	VD	ØRD e8	ØFB H13	ØFC js13	ØUC -1	α	ØRA 7)	VE 7)	ØRA 8)	VE 8)
40	22/28	14	256	-	30	5	90	9	108	130	60 °	52	40	52	20
50	28/36	18	264	-	30	5	110	11	130	160	60 °	65	40	65	16
63	36/45	22	297	-	35	5	130	13.5	155	185	60 °	75	45	75	17
80	45/56	20	315	-	35	5	145	13.5	170	200	60 °	95	45	95	13
100	56/70	30	375	-	45	5	175	17.5	205	245	60 °	115	55	115	20
125	70/90	32	432	-	50	5	210	22	245	295	60 °	135	60	135	17
140	90/100	35	475	-	50	10	230	22	265	315	60 °	155	70	155	22
160	100/110	40	535	-	60	10	275	30	325	385	60 °	200	80	200	80
180	110/125	40	585	-	70	10	300	30	360	420	60 °	220	90	220	90
200	125/140	40	615	-	75	10	320	33	375	445	60 °	235	95	235	95
220	140/160	40	720	-	85	10	370	33	430	490	60 °	270	115	270	115
250	160/180	40	744	-	85	10	415	39	485	555	60 °	300	125	300	125
280	180/200	40	839	31	95	10	450	39	520	590	60 °	325	130	325	130
320	200/220	40	935	-	120	10	510	45	600	680	60 °	365	155	365	155

ØAL = piston Ø

ØMM = piston rod Ø

X* = stroke length

X*min = min. stroke length

With hydraulic cylinders with end position cushioning, observe the notice on page 68!

1) Bleeding: With view to the piston rod, the position is offset by 90° in relation to the line connection (clockwise)

2) Ø D4 max. 0.5 mm deep

3) Throttle valve only with end position cushioning "E" (180° for bleeding)

4) Flange connections see separate table pages 42 and 43

5) Thread design "G"

6) Thread design "A"

7) Dimensions for cylinders with seal design M, T, G, L, R, S and V

8) Dimensions for cylinders with seal design A and B

9) Observe the min. stroke length "X*min"

16) Line connection "B" and "C"

17) Line connection "M"

Dimensions

Trunnion mounting CDH1/CGH1: MT4 (dimensions in mm)

CDH1 MT4

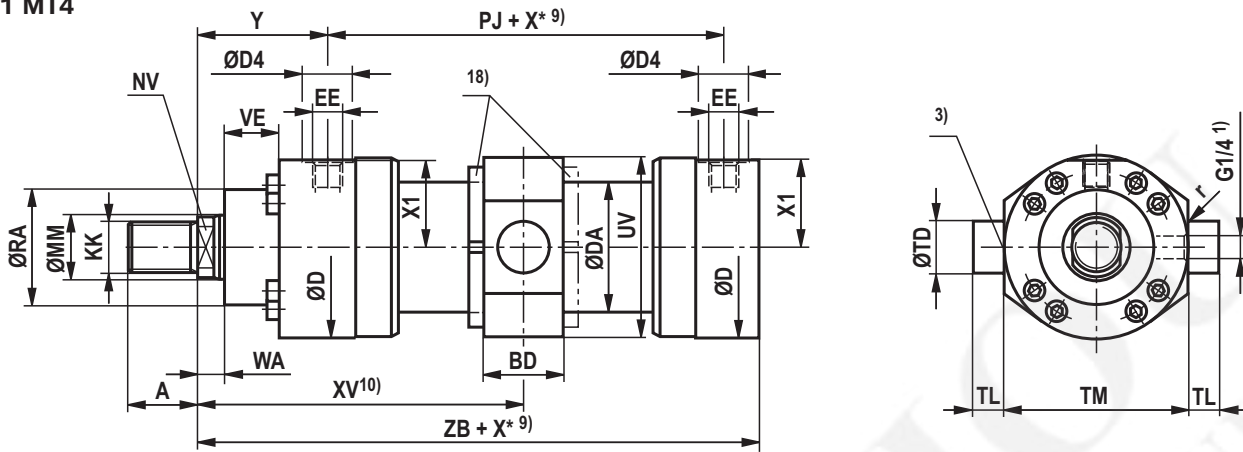

CDH1 MT4: with seal design "A", "B" and $\text{ØAL } 160 - 320 \text{ mm}$

Dimensions for cylinder with piston rod extension "LY" in retracted condition

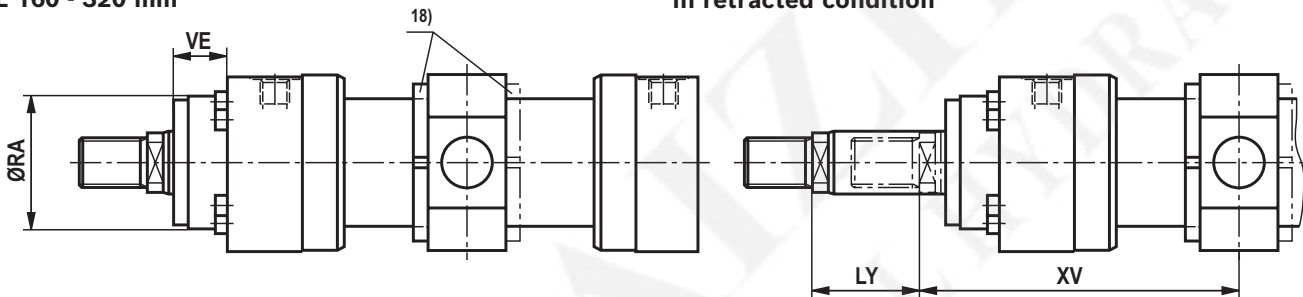

CGH1 MT4

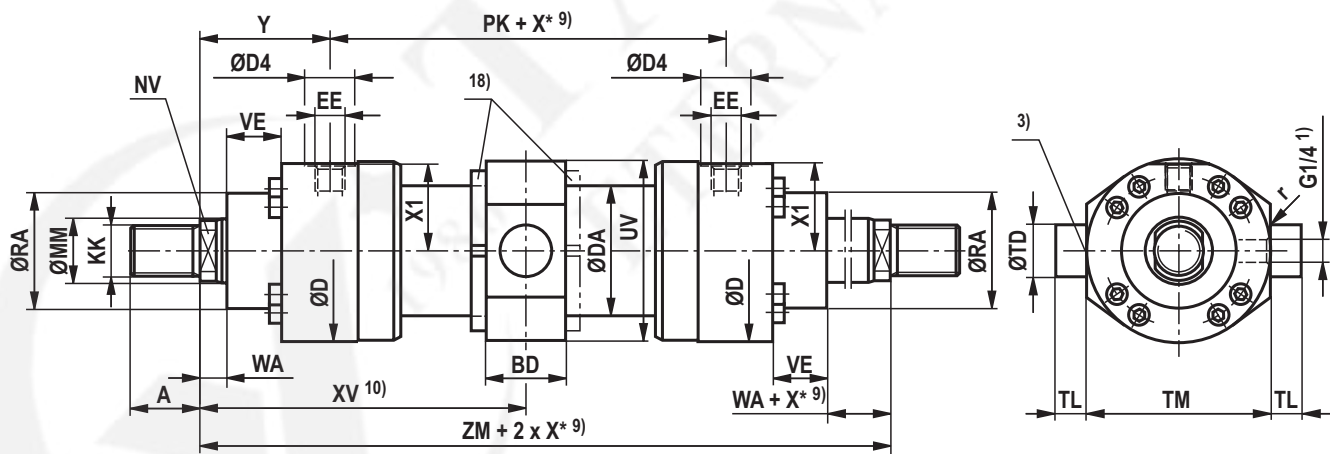

CGH1 MT4: with seal design "A", "B" and $\text{ØAL } 160 - 320 \text{ mm}$

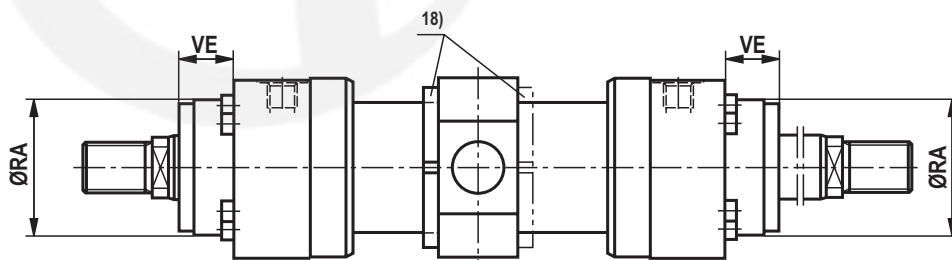

Notice: During installation, it must be ensured that the trunnion bearings are installed up to the trunnion shoulders. Any variation may reduce the product's service life.

Dimensions

Trunnion mountings CDH1/CGH1: MT4 (dimensions in mm)

ØAL	ØMM	KK 5)	A 5)	KK 6)	A 6)	NV	ØD	ØDA	ØD4 2)	EE 4; 16)	EE 4; 17)	Y	PJ	X1	WA
40	22/28	M16x1,5	16	M18x2	30	16/22	88	52	34	G1/2	M22x1,5	79	120	41	14
50	28/36	M22x1,5	22	M24x2	35	22/30	102	62	34	G1/2	M22x1,5	87	120	48.5	18
63	36/45	M28x1,5	28	M30x2	45	30/36	120	78	42	G3/4	M27x2	100	133	56.5	22
80	45/56	M35x1,5	35	M39x3	55	36/46	140	95	42	G3/4	M27x2	104	146	67	20
100	56/70	M45x1,5	45	M50x3	75	46/60	170	125	47	G1	M33x2	124	171	82	30
125	70/90	M58x1,5	58	M64x3	95	60/75	206	150	58	G1 1/4	M42x2	135	205	99	32
140	90/100	M65x1,5	65	M80x3	110	75/85	226	170	58	G1 1/4	M42x2	156	219	109.5	35
160	100/110	M80x2	80	M90x3	120	85/95	265	190	65	G1 1/2	M48x2	185	240	129	40
180	110/125	M100x2	100	M100x3	140	95/110	292	210	65	G1 1/2	M48x2	199	264	142.5	40
200	125/140	M110x2	110	M110x4	150	110/120	310	235	65	G1 1/2	M48x2	205	278	152	40
220	140/160	M120x3	120	M120x4	160	120/140	355	273	65	G1 1/2	M48x2	242	326	174	40
250	160/180	M120x3	120	M120x4	160	140/160	395	305	65	G1 1/2	M48x2	266	326	194	40
280	180/200	M130x3	130	M150x4	190	160/180	425	343	65	G1 1/2	M48x2	282	375	210	40
320	200/220	-	-	M160x4	200	180/200	490	394	65	G1 1/2	M48x2	287	431	243	40

ØAL	ØMM	PK	ZB	ZM	X* min	XV 11) cent	XV 10) min	XV 10) max	BD	UV 12)	ØTD e8	TL js16	TM h12	r	ØRA 7)	VE 7)	ØRA 8)	VE 8)
40	22/28	120	226	278	22	139+X*/2	150	136+X*	38	97	30	20	95	1.6	52	40	52	20
50	28/36	120	233	294	32	147+X*/2	163	140+X*	38	111	30	20	115	1.6	65	40	65	16
63	36/45	133	262	333	47	166.5+X*/2	190	155+X*	48	129	35	20	130	2	75	45	75	17
80	45/56	146	280	354	58	177+X*/2	206	160+X*	58	153	40	25	145	2	95	45	95	13
100	56/70	171	330	419	79	209.5+X*/2	249	185+X*	78	183	50	30	175	2	115	55	115	20
125	70/90	205	382	475	91	237.5+X*/2	283	192+X*	98	220	60	40	210	2.5	135	60	135	17
140	90/100	219	420	531	121	265.5+X*/2	326	205+X*	118	243	65	42.5	230	2.5	155	70	155	22
160	100/110	240	475	610	142	305+X*/2	376	234+X*	128	282	75	52.5	275	2.5	200	80	200	80
180	110/125	264	515	661	158	331+X*/2	410	252+X*	138	310	85	55	300	2.5	220	90	220	90
200	125/140	278	535	688	194	344+X*/2	441	247+X*	168	331	90	55	320	2.5	235	95	235	95
220	140/160	326	635	810	155	405+X*/2	482.5	327.5+X*	135	377	100	60	370	2.5	270	115	270	115
250	160/180	326	659	858	175	429+X*/2	516.5	341.5+X*	145	417	110	65	410	2.5	300	125	300	125
280	180/200	375	744	939	336	469.5+X*/2	637.5	301.5+X*	165	448	130	70	450	2.5	325	130	325	130
320	200/220	431	815	1005	180	502.5+X*/2	592.5	412.5+X*	195	513	160	90	510	2.5	365	155	365	155

ØAL = piston Ø
ØMM = piston rod Ø
X* = stroke length
X*min = min. stroke length

With hydraulic cylinders with end position cushioning, observe the notice on page 68!

- 1) Bleeding: With view to the piston rod, the position is offset by 90° in relation to the line connection (clockwise)
- 2) Ø D4 max. 0.5 mm deep
- 3) Throttle valve only with end position cushioning "E" (180° for bleeding)
- 4) Flange connections see separate table pages 42 and 43
- 5) Thread design "G"
- 6) Thread design "A"

- 7) Dimensions for cylinders with seal design M, T, G, L, R, S, V
- 8) Dimensions for cylinders with seal design A and B
- 9) Observe the min. stroke length "X*min"
- 10) When ordering, always specify the "XV" dimension in the clear text. Preferred XV dimension: Observe the trunnion position in the cylinder center XVmin and XVmax
- 11) XVcent recommendation: Trunnion position in cylinder center
- 12) The specified dimensions are maximum values, tolerance classes 342 according to ISO 9013 Thermal cutting
- 16) Line connection "B" and "C"
- 17) Line connection "M"
- 18) Trunnion nut with ØAL ≥ 125 mm either at head or at base side depending on the position of the trunnion (XV)

Dimensions

Foot mounting CDH1/CGH1: MS2 (dimensions in mm)

CDH1 MS2

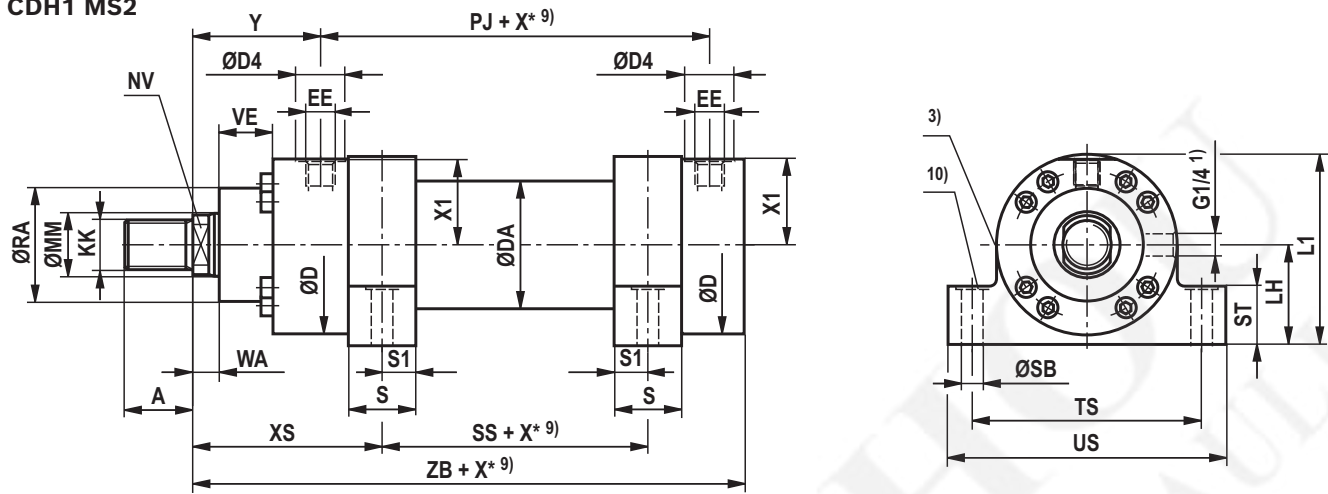

CDH1 MS2: with seal design "A", "B" and $\text{ØAL } 160 - 320 \text{ mm}$

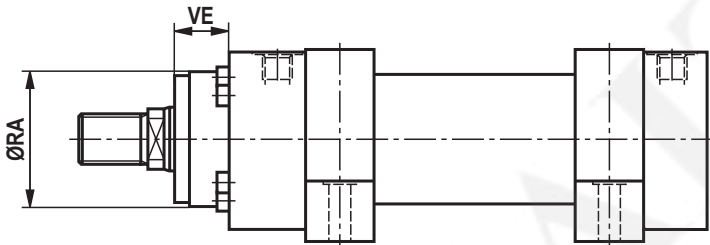

CGH1 MS2

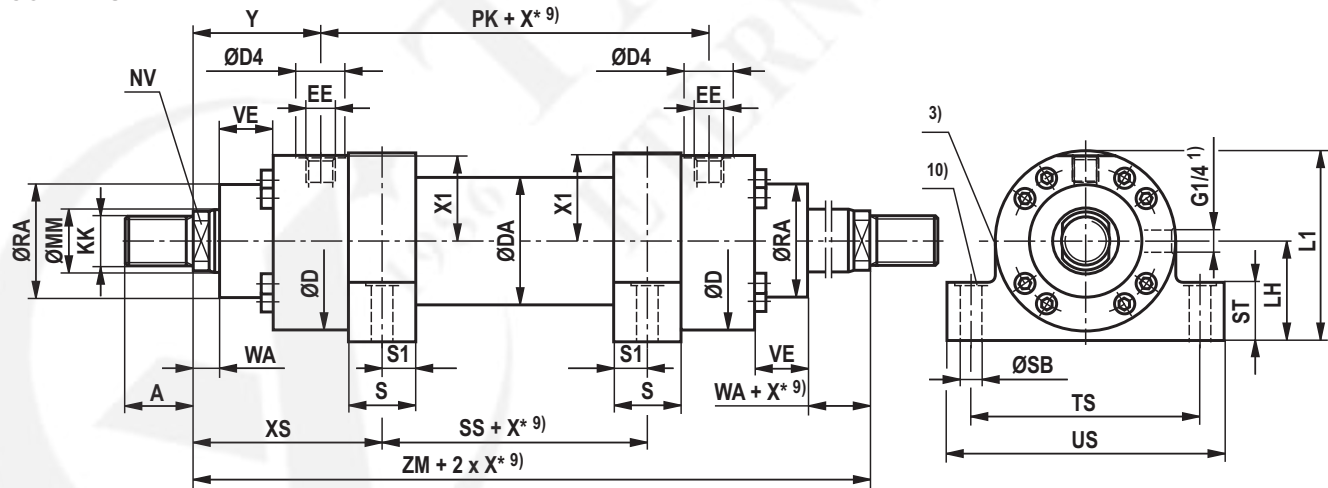

CGH1 MS2: with seal design "A", "B" and $\text{ØAL } 160 - 320 \text{ mm}$

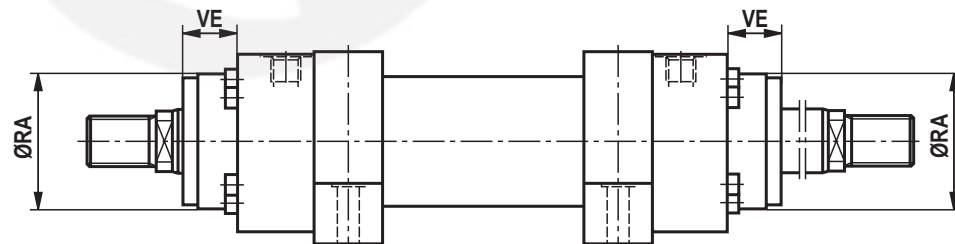

Dimensions

Foot mounting CDH1/CGH1: MS2 (dimensions in mm)

ØAL	ØMM	KK 5)	A 5)	KK 6)	A 6)	NV	ØD	ØDA	ØD4 2)	EE 4; 16)	EE 4; 17)	Y	PJ	X1	WA
40	22/28	M16x1,5	16	M18x2	30	16/22	88	52	34	G1/2	M22x1,5	79	120	41	14
50	28/36	M22x1,5	22	M24x2	35	22/30	102	62	34	G1/2	M22x1,5	87	120	48.5	18
63	36/45	M28x1,5	28	M30x2	45	30/36	120	78	42	G3/4	M27x2	100	133	56.5	22
80	45/56	M35x1,5	35	M39x3	55	36/46	140	95	42	G3/4	M27x2	104	146	67	20
100	56/70	M45x1,5	45	M50x3	75	46/60	170	125	47	G1	M33x2	124	171	82	30
125	70/90	M58x1,5	58	M64x3	95	60/75	206	150	58	G1 1/4	M42x2	135	205	99	32
140	90/100	M65x1,5	65	M80x3	110	75/85	226	170	58	G1 1/4	M42x2	156	219	109.5	35
160	100/110	M80x2	80	M90x3	120	85/95	265	190	65	G1 1/2	M48x2	185	240	129	40
180	110/125	M100x2	100	M100x3	140	95/110	292	210	65	G1 1/2	M48x2	199	264	142.5	40
200	125/140	M110x2	110	M110x4	150	110/120	310	235	65	G1 1/2	M48x2	205	278	152	40
220	140/160	M120x3	120	M120x4	160	120/140	355	273	65	G1 1/2	M48x2	242	326	174	40
250	160/180	M120x3	120	M120x4	160	140/160	395	305	65	G1 1/2	M48x2	266	326	194	40
280	180/200	M130x3	130	M150x4	190	160/180	425	343	65	G1 1/2	M48x2	282	375	210	40
320	200/220	-	-	M160x4	200	180/200	490	394	65	G1 1/2	M48x2	287	431	243	40

ØAL	ØMM	PK	XS	ZB	ZM	SS	X* min	S	S1	ØSB H13	ST	TS js13	US max	LH	L1 12)	ØRA 7)	VE 7)	ØRA 8)	VE 8)
40	22/28	120	114	226	278	50	-	30	15	11	32	110	140	45	93	52	40	52	20
50	28/36	120	124.5	233	294	45	-	35	17.5	11	37	130	161	55	110	65	40	65	16
63	36/45	133	142	262	333	49	-	40	20	13.5	42	150	183	65	129	75	45	75	17
80	45/56	146	151	280	354	52	2	50	25	17.5	47	180	220	75	149	95	45	95	13
100	56/70	171	179	330	419	61	3	60	30	22	57	210	260	90	181	115	55	115	20
125	70/90	205	200	382	475	75	-	70	35	26	67	255	313	105	215	135	60	135	17
140	90/100	219	230.5	420	531	70	19	85	42.5	30	72	290	359	115	235	155	70	155	22
160	100/110	240	272.5	475	610	65	44	105	52.5	33	77	330	402	135	277	200	80	200	80
180	110/125	264	296.5	515	662	69	50	115	57.5	40	92	360	445	150	305	220	90	220	90
200	125/140	278	307.5	535	688	73	56	125	62.5	40	97	385	471	160	322	235	95	235	95
220	140/160	326	367.5	635	810	75	100	155	77.5	45	102	445	541	185	373	270	115	270	115
250	160/180	326	391.5	659	858	75	100	155	77.5	52	112	500	610	205	414	300	125	300	125
280	180/200	375	407.5	744	939	124	171	155	77.5	52	127	530	641	225	449	325	130	325	130
320	200/220	431	440	815	1005	125	85	190	95	62	142	610	732	255	512	365	155	365	155

ØAL = piston Ø

ØMM = piston rod Ø

X* = stroke length

X*min = min. stroke length

With hydraulic cylinders with end position cushioning,
observe the notice on page 68!

1) Bleeding: With view to the piston rod, the position is offset by 90°
in relation to the line connection (clockwise)

2) Ø D4 max. 0.5 mm deep

3) Throttle valve only with end position cushioning "E"
(180° for bleeding)

4) Flange connections see separate table pages 42 and 43

5) Thread design "G"

6) Thread design "A"

7) Dimensions for cylinders with seal design M, T, G, L, R, S and V

8) Dimensions for cylinders with seal design A and B

9) Observe the min. stroke length "X*min"

10) Recess 2 mm deep for hexagon socket head cap screws;
ISO 4762 – The screws must not be subjected to shear force.
Force distribution via additional external fitting strip

16) Line connection "B" and "C"

17) Line connection "M"

Dimensions

Swivel eye at base CSH1: MP3 (dimensions in mm)

CSH1 MP3; ØAL 40-200 mm

for position measurement system output "C", "F" and "D"

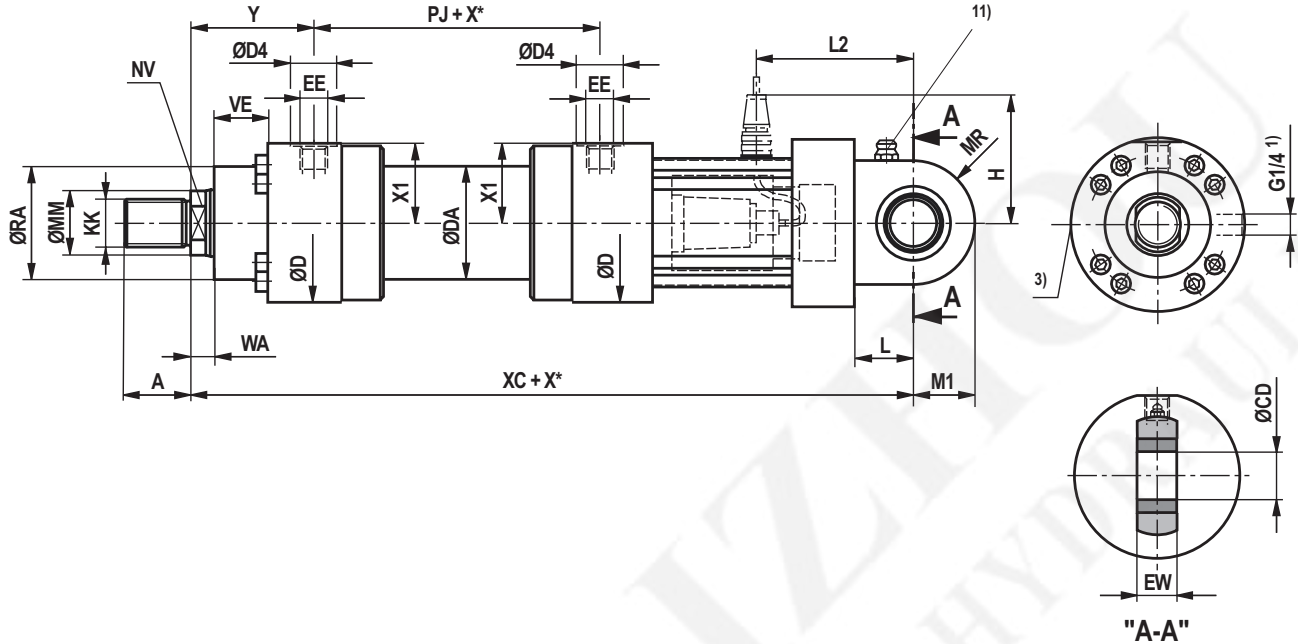

CSH1 MP3; ØAL 40-200 mm

for position measurement system output "N" and "P"

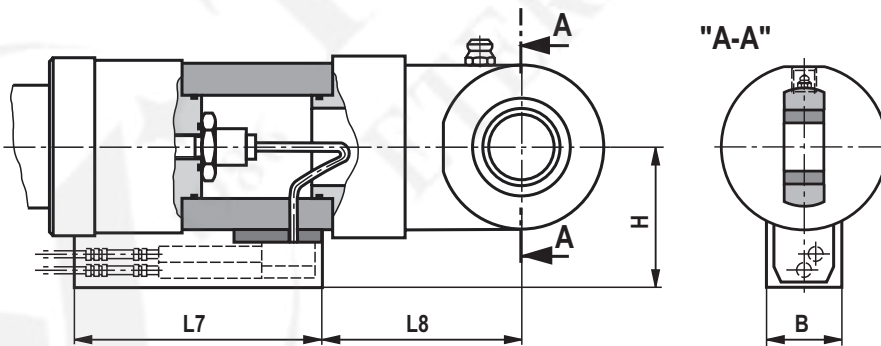

Dimensions

Swivel eye at base CSH1: MP3 (dimensions in mm)

ØAL	ØMM	KK 5)	A 5)	KK 6)	A 6)	NV	ØD	ØDA	ØD4 2)	EE 4; 16)	EE 4; 17)	Y	PJ	X* max
40	28	M16x1,5	16	M18x2	30	22	88	52	34	G1/2	M22x1,5	79	120	1000
50	28/36	M22x1,5	22	M24x2	35	22/30	102	62	34	G1/2	M22x1,5	87	120	1000
63	36/45	M28x1,5	28	M30x2	45	30/36	120	78	42	G3/4	M27x2	100	133	2000
80	45/56	M35x1,5	35	M39x3	55	36/46	140	95	42	G3/4	M27x2	104	146	2000
100	56/70	M45x1,5	45	M50x3	75	46/60	170	125	47	G1	M33x2	124	171	3000
125	70/90	M58x1,5	58	M64x3	95	60/75	206	150	58	G1 1/4	M42x2	135	205	3000
140	90/100	M65x1,5	65	M80x3	110	75/85	226	170	58	G1 1/4	M42x2	156	219	3000
160	100/110	M80x2	80	M90x3	120	85/95	265	190	65	G1 1/2	M48x2	185	240	3000
180	110/125	M100x2	100	M100x3	140	95/110	292	210	65	G1 1/2	M48x2	199	264	3000
200	125/140	M110x2	110	M110x4	150	110/120	310	235	65	G1 1/2	M48x2	205	278	3000

ØAL	ØMM	X1	WA	XC	L	MR	M1	ØCD H11	EW -0.4	ØRA	VE	L2	H 14)	H 13)	L7	L8	B
40	28	41	14	417	32.5	31	28	25	23	52	40	98	115	106	200	75	64
50	28/36	48.5	18	430	37.5	36	32.5	30	28	65	40	103	120	113	200	80	64
63	36/45	56.5	22	480	45	42	40	35	30	75	45	116	130	122	200	93	64
80	45/56	67	20	515	50	52	50	40	35	95	45	132	125	133	200	104	64
100	56/70	82	30	560	60	65	62.5	50	40	115	55	145	135	148	200	117	64
125	70/90	99	32	620	70	70	70	60	50	135	60	172	145	166	200	148	64
140	90/100	109.5	35	665	75	82	82	70	55	155	70	182	155	176	200	156	64
160	100/110	129	40	720	85	95	95	80	60	200	80	200	165	196	200	168	64
180	110/125	142.5	40	775	90	113	113	90	65	220	90	222	175	210	200	189	64
200	125/140	152	40	815	115	125	125	100	70	235	95	237	190	217	200	206	64

ØAL = piston Ø
ØMM = piston rod Ø
X* = stroke length
X*max = max. stroke length

- 1) Bleeding: With view to the piston rod, the position is offset by 90° in relation to the line connection (clockwise)
- 2) Ø D4 max. 0.5 mm deep
- 3) Throttle valve only with end position cushioning "E" (180° for bleeding)
- 4) Flange connections see separate table pages 42 and 43

- 5) Thread design "G"
- 6) Thread design "A"
- 11) Standard version "W"
Grease nipple, cone head form A according to DIN 71412
- 13) Dimensions for position measurement system output "N" and "P"
- 14) Dimensions for position measurement system output "C", "F" and "D"
- 16) Line connection "B" and "C"
- 17) Line connection "M"

Dimensions

Self-aligning clevis at base CSH1: MP5 (dimensions in mm)

CSH1 MP5

for position measurement system output "C", "F" and "D"

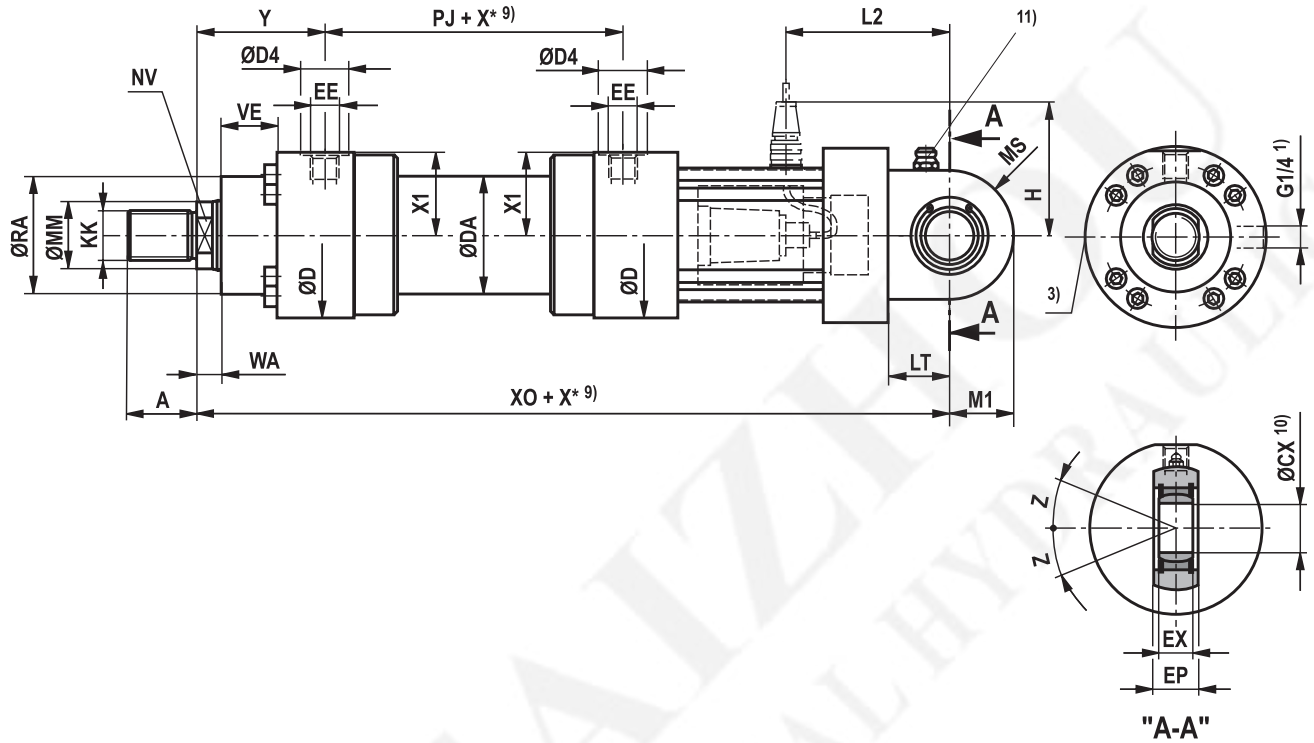

CSH1 MP5

for position measurement system output "N" and "P"

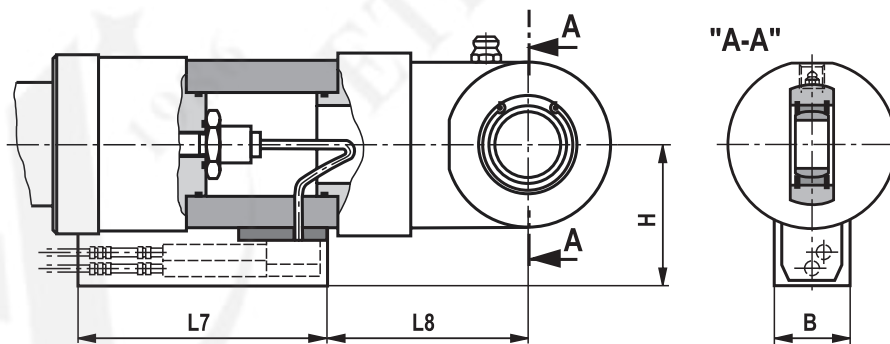

Dimensions

Self-aligning clevis at base CSH1: MP5 (dimensions in mm)

ØAL	ØMM	KK 5)	A 5)	KK 6)	A 6)	NV	ØD	ØDA	ØD4 2)	EE 4; 16)	EE 4; 17)	Y	PJ	X1	X* max	C ₀ ¹⁸⁾ kN
40	28	M16x1,5	16	M18x2	30	22	88	52	34	G1/2	M22x1,5	79	120	41	1000	72
50	28/36	M22x1,5	22	M24x2	35	22/30	102	62	34	G1/2	M22x1,5	87	120	48.5	1000	106
63	36/45	M28x1,5	28	M30x2	45	30/36	120	78	42	G3/4	M27x2	100	133	56.5	2000	153
80	45/56	M35x1,5	35	M39x3	55	36/46	140	95	42	G3/4	M27x2	104	146	67	2000	250
100	56/70	M45x1,5	45	M50x3	75	46/60	170	125	47	G1	M33x2	124	171	82	3000	365
125	70/90	M58x1,5	58	M64x3	95	60/75	206	150	58	G1 1/4	M42x2	135	205	99	3000	400
140	90/100	M65x1,5	65	M80x3	110	75/85	226	170	58	G1 1/4	M42x2	156	219	109.5	3000	540
160	100/110	M80x2	80	M90x3	120	85/95	265	190	65	G1 1/2	M48x2	185	240	129	3000	670
180	110/125	M100x2	100	M100x3	140	95/110	292	210	65	G1 1/2	M48x2	199	264	142.5	3000	980
200	125/140	M110x2	110	M110x4	150	110/120	310	235	65	G1 1/2	M48x2	205	278	152	3000	1120
220	140/160	M120x3	120	M120x4	160	120/140	355	273	65	G1 1/2	M48x2	242	326	174	3000	1700
250	160/180	M120x3	120	M120x4	160	140/160	395	305	65	G1 1/2	M48x2	266	326	194	3000	1700
280	180/200	M130x3	130	M150x4	190	160/180	425	343	65	G1 1/2	M48x2	282	375	210	3000	2900
320	200/220	-	-	M160x4	200	180/200	490	394	65	G1 1/2	M48x2	287	431	242	3000	-

ØAL	ØMM	F _{adm} ¹⁹⁾ kN	WA	XO	X* min	LT	M1	MS	ØCX	EP -0.4	EX	Z	ØRA	VE	L2	H 14)	H 13)	L7	L8	B
40	28	25.9	14	417	-	32.5	28	31	25 _{-0.010}	23	20 _{-0.12}	7 °	52	40	98	115	106	200	75	64
50	28/36	38.2	18	430	-	37.5	32.5	36	30 _{-0.010}	28	22 _{-0.12}	6 °	65	40	103	120	113	200	80	64
63	36/45	55.1	22	480	-	45	40	42	35 _{-0.012}	30	25 _{-0.12}	6 °	75	45	116	130	122	200	93	64
80	45/56	90.0	20	515	-	50	50	52	40 _{-0.012}	35	28 _{-0.12}	7 °	95	45	132	125	133	200	104	64
100	56/70	131.4	30	560	-	60	62.5	65	50 _{-0.012}	40	35 _{-0.12}	6 °	115	55	145	135	148	200	117	64
125	70/90	144.0	32	620	-	70	70	70	60 _{-0.015}	50	44 _{-0.15}	6 °	135	60	172	145	166	200	148	64
140	90/100	194.4	35	665	-	75	82	82	70 _{-0.015}	55	49 _{-0.15}	6 °	155	70	182	155	176	200	156	64
160	100/110	241.2	40	720	-	85	95	95	80 _{-0.015}	60	55 _{-0.15}	6 °	200	80	200	165	196	200	168	64
180	110/125	352.8	40	775	-	90	113	113	90 _{-0.020}	65	60 _{-0.20}	5 °	220	90	222	175	210	200	189	64
200	125/140	403.2	40	815	-	115	125	125	100 _{-0.020}	70	70 _{-0.20}	7 °	235	95	237	190	217	200	206	64
220	140/160	612.0	40	960	-	125	150 ¹²⁾	140 ¹²⁾	110 _{-0.020}	80	70 _{-0.20}	6 °	270	115	280	205	254	200	248	64
250	160/180	612.0	40	1000	-	140	168 ¹²⁾	158 ¹²⁾	110 _{-0.020}	80	70 _{-0.20}	6 °	300	125	300	220	269	200	263	64
280	180/200	1044.0	40	1105	31	150	188 ¹²⁾	178 ¹²⁾	120 _{-0.020}	90	85 _{-0.20}	6 °	325	130	330	270	276	200	295	64
320	200/220	-	40	1210	-	175	210 ¹²⁾	200 ¹²⁾	140 _{-0.020}	110	90 _{-0.20}	7 °	365	155	375	300	309	200	340	64

ØAL = piston Ø

ØMM = piston rod Ø

X* = stroke length

X*max = max. stroke length

X*min = min. stroke length

With hydraulic cylinders with end position cushioning, observe the notice on page 68!

1) Bleeding: With view to the piston rod, the position is offset by 90° in relation to the line connection (clockwise)

2) Ø D4 max. 0.5 mm deep

3) Throttle valve only with end position cushioning "E" (180° for bleeding)

4) Flange connections see separate table pages 42 and 43

5) Thread design "G"

6) Thread design "A"

9) Observe the min. stroke length "X*min"

10) Related bolt Ø m6;

Related bolt Ø j6 for maintenance-free spherical bearing

11) Standard version "W"

Grease nipple, cone head form A according to DIN 71412; not applicable to spherical bearing, maintenance-free "A"

12) The specified dimensions are maximum values, tolerance classes 342 according to ISO 9013 Thermal cutting

13) Dimensions for position measurement system output "N" and "P"

14) Dimensions for position measurement system output "C", "F" and "D"

16) Line connection "B" and "C"

17) Line connection "M"

18) C₀ = static load rating of the swivel head

19) F_{adm} = max. admissible load of the swivel head with oscillatory or alternating loads

Dimensions

Round flange at head CSH1: MF3 (dimensions in mm)

CSH1 MF3

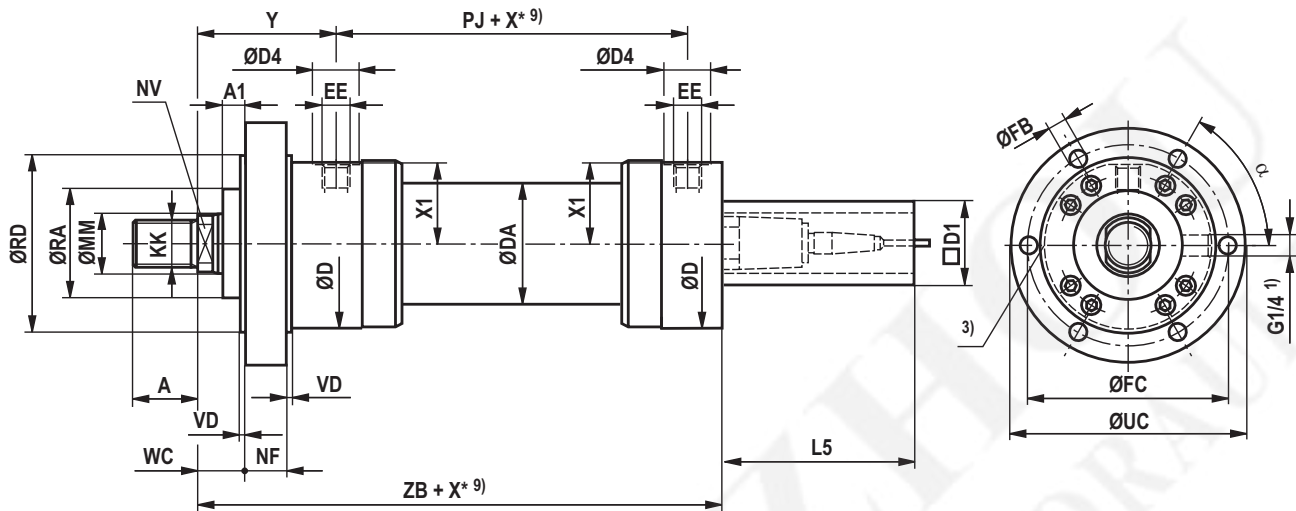

Dimensions

Round flange at head CSH1: MF3 (dimensions in mm)

ØAL	ØMM	KK 5)	A 5)	KK 6)	A 6)	NV	ØD	ØDA	ØD4 2)	EE 4; 16)	EE 4; 17)	Y	PJ	X1	L5
40	28	M16x1,5	16	M18x2	30	22	88	52	34	G1/2	M22x1,5	79	120	41	166
50	28/36	M22x1,5	22	M24x2	35	22/30	102	62	34	G1/2	M22x1,5	87	120	48.5	166
63	36/45	M28x1,5	28	M30x2	45	30/36	120	78	42	G3/4	M27x2	100	133	56.5	166
80	45/56	M35x1,5	35	M39x3	55	36/46	140	95	42	G3/4	M27x2	104	146	67	166
100	56/70	M45x1,5	45	M50x3	75	46/60	170	125	47	G1	M33x2	124	171	82	166
125	70/90	M58x1,5	58	M64x3	95	60/75	206	150	58	G1 1/4	M42x2	135	205	99	166
140	90/100	M65x1,5	65	M80x3	110	75/85	226	170	58	G1 1/4	M42x2	156	219	109.5	166
160	100/110	M80x2	80	M90x3	120	85/95	265	190	65	G1 1/2	M48x2	185	240	129	166
180	110/125	M100x2	100	M100x3	140	95/110	292	210	65	G1 1/2	M48x2	199	264	142.5	166
200	125/140	M110x2	110	M110x4	150	110/120	310	235	65	G1 1/2	M48x2	205	278	152	166
220	140/160	M120x3	120	M120x4	160	120/140	355	273	65	G1 1/2	M48x2	242	326	174	166
250	160/180	M120x3	120	M120x4	160	140/160	395	305	65	G1 1/2	M48x2	266	326	194	166
280	180/200	M130x3	130	M150x4	190	160/180	425	343	65	G1 1/2	M48x2	282	375	210	166
320	200/220	-	-	M160x4	200	180/200	490	394	65	G1 1/2	M48x2	287	431	243	166

ØAL	ØMM	X* max	ØRD e8	WC	VD	NF	A1	ZB	X* min	ØFB H13	ØFC js13	ØUC -1	α	ØRA	D1 max
40	28	1000	90	19	5	30	0	235	-	9	108	130	60 °	52	80
50	28/36	1000	110	23	5	30	0	243	-	11	130	160	60 °	65	96
63	36/45	2000	130	27	5	35	0	287	-	13.5	155	185	60 °	75	96
80	45/56	2000	145	25	5	35	0	312	-	13.5	170	200	60 °	95	96
100	56/70	3000	175	35	5	45	0	352	-	17.5	205	245	60 °	115	96
125	70/90	3000	210	37	5	50	0	392	-	22	245	295	60 °	135	96
140	90/100	3000	230	45	10	50	0	430	-	22	265	315	60 °	155	96
160	100/110	3000	275	50	10	60	0	475	-	30	325	385	60 °	200	96
180	110/125	3000	300	50	10	70	0	515	-	30	360	420	60 °	220	96
200	125/140	3000	320	50	10	75	0	535	-	33	375	445	60 °	235	96
220	140/160	3000	370	60	10	85	20	635	-	33	430	490	60 °	270	96
250	160/180	3000	415	70	10	85	30	659	-	39	485	555	60 °	300	96
280	180/200	3000	450	65	10	95	25	744	31	39	520	590	60 °	325	96
320	200/220	3000	510	65	10	120	25	815	-	45	600	680	60 °	365	96

ØAL = piston Ø

ØMM = piston rod Ø

X* = stroke length

X*max = max. stroke length

X*min = min. stroke length

With hydraulic cylinders with end position cushioning, observe the notice on page 68!

1) Bleeding: With view to the piston rod, the position is offset by 90° in relation to the line connection (clockwise)

2) Ø D4 max. 0.5 mm deep

3) Throttle valve only with end position cushioning "E" (180° for bleeding)

4) Flange connections see separate table pages 42 and 43

5) Thread design "G"

6) Thread design "A"

9) Observe the min. stroke length "X*min"

16) Line connection "B" and "C"

17) Line connection "M"

Dimensions

Round flange at base CSH1: MF4 (dimensions in mm)

CSH1 MF4; ØAL 40-100 mm

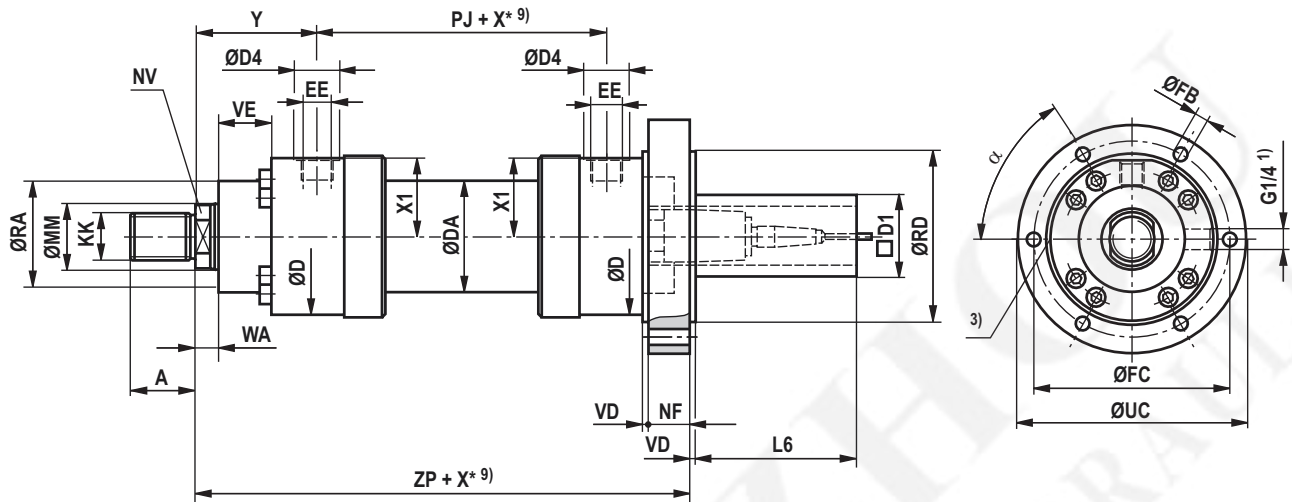

CSH1 MF4; ØAL 125-320 mm

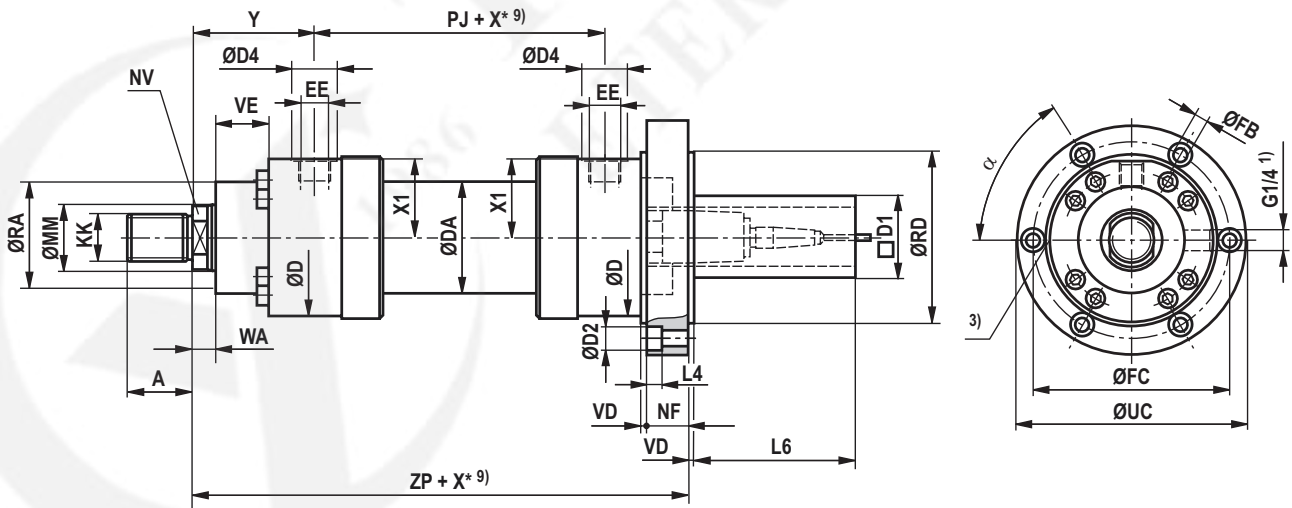

Dimensions

Round flange at base CSH1: MF4 (dimensions in mm)

ØAL	ØMM	KK 5)	A 5)	KK 6)	A 6)	NV	ØD	ØDA	ØD4 2)	EE 4; 16)	EE 4; 17)	Y	PJ	X1	L4	ØD2	X* max
40	28	M16x1,5	16	M18x2	30	22	88	52	34	G1/2	M22x1,5	79	120	41	0	0	1000
50	28/36	M22x1,5	22	M24x2	35	22/30	102	62	34	G1/2	M22x1,5	87	120	48.5	0	0	1000
63	36/45	M28x1,5	28	M30x2	45	30/36	120	78	42	G3/4	M27x2	100	133	56.5	0	0	2000
80	45/56	M35x1,5	35	M39x3	55	36/46	140	95	42	G3/4	M27x2	104	146	67	0	0	2000
100	56/70	M45x1,5	45	M50x3	75	46/60	170	125	47	G1	M33x2	124	171	82	0	0	3000
125	70/90	M58x1,5	58	M64x3	95	60/75	206	150	58	G1 1/4	M42x2	135	205	99	21.5	33	3000
140	90/100	M65x1,5	65	M80x3	110	75/85	226	170	58	G1 1/4	M42x2	156	219	109.5	21.5	33	3000
160	100/110	M80x2	80	M90x3	120	85/95	265	190	65	G1 1/2	M48x2	185	240	129	28.5	43	3000
180	110/125	M100x2	100	M100x3	140	95/110	292	210	65	G1 1/2	M48x2	199	264	142.5	28.5	43	3000
200	125/140	M110x2	110	M110x4	150	110/120	310	235	65	G1 1/2	M48x2	205	278	152	32	48	3000
220	140/160	M120x3	120	M120x4	160	120/140	355	273	65	G1 1/2	M48x2	242	326	174	32	48	3000
250	160/180	M120x3	120	M120x4	160	140/160	395	305	65	G1 1/2	M48x2	266	326	194	38	57	3000
280	180/200	M130x3	130	M150x4	190	160/180	425	343	65	G1 1/2	M48x2	282	375	210	38	57	3000
320	200/220	-	-	M160x4	200	180/200	490	394	65	G1 1/2	M48x2	287	431	243	44	66	3000

ØAL	ØMM	WA	ZP	X* min	NF	VD	ØRD e8	ØFB H13	ØFC js13	ØUC -1	α	ØRA	VE	L6	D1 max
40	28	14	265	-	30	5	90	9	108	130	60 °	52	40	166	80
50	28/36	18	274	-	30	5	110	11	130	160	60 °	65	40	166	96
63	36/45	22	310	-	35	5	130	13.5	155	185	60 °	75	45	166	96
80	45/56	20	330	-	35	5	145	13.5	170	200	60 °	95	45	143	96
100	56/70	30	390	-	45	5	175	17.5	205	245	60 °	115	55	123	96
125	70/90	32	432	-	50	5	210	22	245	295	60 °	135	60	121	96
140	90/100	35	475	-	50	10	230	22	265	315	60 °	155	70	111	96
160	100/110	40	535	-	60	10	275	30	325	385	60 °	200	80	96	96
180	110/125	40	585	-	70	10	300	30	360	420	60 °	220	90	86	96
200	125/140	40	615	-	75	10	320	33	375	445	60 °	235	95	76	96
220	140/160	40	720	-	85	10	370	33	430	490	60 °	270	115	71	96
250	160/180	40	744	-	85	10	415	39	485	555	60 °	300	125	71	96
280	180/200	40	839	31	95	10	450	39	520	590	60 °	325	130	61	96
320	200/220	40	935	-	120	10	510	45	600	680	60 °	365	155	36	96

ØAL = piston Ø
 ØMM = piston rod Ø
 X* = stroke length
 X*max = max. stroke length
 X*min = min. stroke length
 With hydraulic cylinders with end position cushioning,
 observe the notice on page 68!

- 1) Bleeding: With view to the piston rod, the position is offset by 90° in relation to the line connection (clockwise)
- 2) Ø D4 max. 0.5 mm deep
- 3) Throttle valve only with end position cushioning "E" (180° for bleeding)
- 4) Flange connections see separate table pages 42 and 43
- 5) Thread design "G"
- 6) Thread design "A"
- 9) Observe the min. stroke length "X*min"
- 16) Line connection "B" and "C"
- 17) Line connection "M"

Dimensions

Trunnion mounting CSH1: MT4 (dimensions in mm)

ØAL	ØMM	KK 5)	A 5)	KK 6)	A 6)	NV	ØD	ØDA	ØD4 2)	EE 4; 16)	EE 4; 17)	Y	PJ	X1	WA	L5	X* max
40	28	M16x1,5	16	M18x2	30	22	88	52	34	G1/2	M22x1,5	79	120	41	14	166	1000
50	28/36	M22x1,5	22	M24x2	35	22/30	102	62	34	G1/2	M22x1,5	87	120	48.5	18	166	1000
63	36/45	M28x1,5	28	M30x2	45	30/36	120	78	42	G3/4	M27x2	100	133	56.5	22	166	2000
80	45/56	M35x1,5	35	M39x3	55	36/46	140	95	42	G3/4	M27x2	104	146	67	20	166	2000
100	56/70	M45x1,5	45	M50x3	75	46/60	170	125	47	G1	M33x2	124	171	82	30	166	3000
125	70/90	M58x1,5	58	M64x3	95	60/75	206	150	58	G1 1/4	M42x2	135	205	99	32	166	3000
140	90/100	M65x1,5	65	M80x3	110	75/85	226	170	58	G1 1/4	M42x2	156	219	109.5	35	166	3000
160	100/110	M80x2	80	M90x3	120	85/95	265	190	65	G1 1/2	M48x2	185	240	129	40	166	3000
180	110/125	M100x2	100	M100x3	140	95/110	292	210	65	G1 1/2	M48x2	199	264	142.5	40	166	3000
200	125/140	M110x2	110	M110x4	150	110/120	310	235	65	G1 1/2	M48x2	205	278	152	40	166	3000
220	140/160	M120x3	120	M120x4	160	120/140	355	273	65	G1 1/2	M48x2	242	326	174	40	166	3000
250	160/180	M120x3	120	M120x4	160	140/160	395	305	65	G1 1/2	M48x2	266	326	194	40	166	3000
280	180/200	M130x3	130	M150x4	190	160/180	425	343	65	G1 1/2	M48x2	282	375	210	40	166	3000
320	200/220	-	-	M160x4	200	180/200	490	394	65	G1 1/2	M48x2	287	431	243	40	166	3000

ØAL	ØMM	ZB	X* min	XV 11) cent	XV 10) min	XV 10) max	BD	UV 12)	ØTD e8	TL js16	TM h12	r	ØRA	VE	D1 max
40	28	235	22	139+X*/2	150	136+X*	38	97	30	20	95	1.6	52	40	80
50	28/36	243	32	147+X*/2	163	140+X*	38	111	30	20	115	1.6	65	40	96
63	36/45	287	47	166.5+X*/2	190	155+X*	48	129	35	20	130	2	75	45	96
80	45/56	312	58	177+X*/2	206	160+X*	58	153	40	25	145	2	95	45	96
100	56/70	352	79	209.5+X*/2	249	185+X*	78	183	50	30	175	2	115	55	96
125	70/90	392	91	237.5+X*/2	283	192+X*	98	220	60	40	210	2.5	135	60	96
140	90/100	430	121	265.5+X*/2	326	205+X*	118	243	65	42.5	230	2.5	155	70	96
160	100/110	475	142	305+X*/2	376	234+X*	128	282	75	52.5	275	2.5	200	80	96
180	110/125	515	158	331+X*/2	410	252+X*	138	310	85	55	300	2.5	220	90	96
200	125/140	535	194	344+X*/2	441	247+X*	168	331	90	55	320	2.5	235	95	96
220	140/160	635	155	405+X*/2	482.5	327.5+X*	135	377	100	60	370	2.5	270	115	96
250	160/180	659	175	429+X*/2	516.5	341.5+X*	145	417	110	65	410	2.5	300	125	96
280	180/200	744	336	469.5+X*/2	637.5	301.5+X*	165	448	130	70	450	2.5	325	130	96
320	200/220	815	180	502.5+X*/2	592.5	412.5+X*	195	513	160	90	510	2.5	365	155	96

ØAL = piston Ø

ØMM = piston rod Ø

X* = stroke length

X*max = max. stroke length

X*min = min. stroke length

With hydraulic cylinders with end position cushioning, observe the notice on page 68!

1) Bleeding: With view to the piston rod, the position is offset by 90° in relation to the line connection (clockwise)

2) Ø D4 max. 0.5 mm deep

3) Throttle valve only with end position cushioning "E" (180° for bleeding)

4) Flange connections see separate table pages 42 and 43

5) Thread design "G"

6) Thread design "A"

9) Observe the min. stroke length "X*min"

10) When ordering, always specify the "XV" dimension in the clear text. Preferred XV dimension: Observe the trunnion position in the cylinder center XVmin and XVmax

11) XVcent recommendation: Trunnion position in cylinder center

12) The specified dimensions are maximum values, tolerance classes 342 according to ISO 9013 Thermal cutting

16) Line connection "B" and "C"

17) Line connection "M"

18) Trunnion nut with ØAL ≥ 125 mm either at head or at base side depending on the position of the trunnion (XV)

Dimensions

Foot mounting CSH1: MS2 (dimensions in mm)

CSH1 MS2

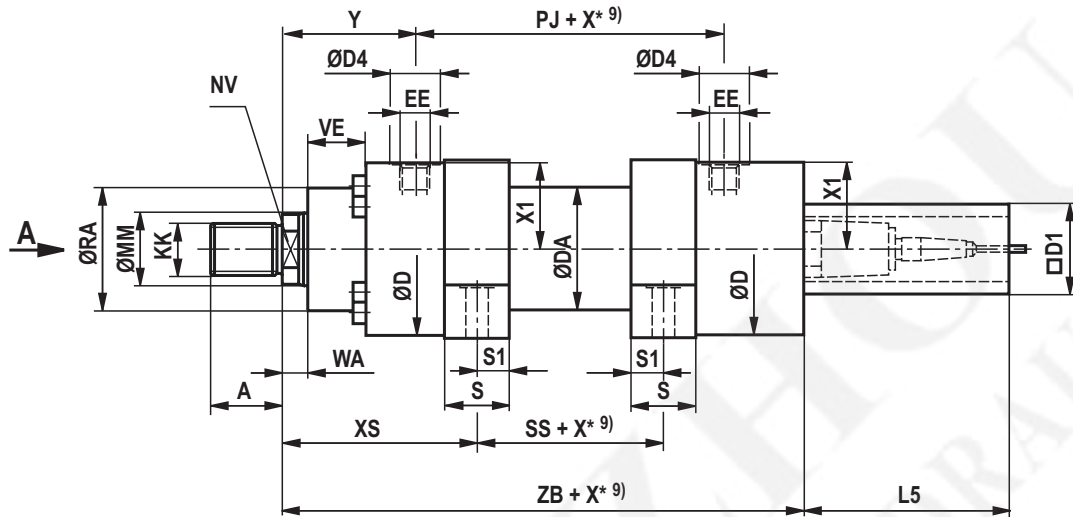

View A

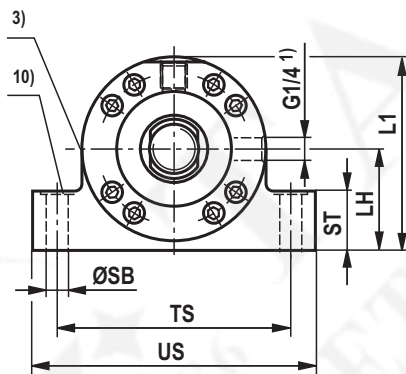

Dimensions

Foot mounting CSH1: MS2 (dimensions in mm)

ØAL	ØMM	KK 5)	A 5)	KK 6)	A 6)	NV	ØD	ØDA	ØD4 2)	EE 4; 16)	EE 4; 17)	Y	PJ	X1	WA	L5	X* max
40	28	M16x1,5	16	M18x2	30	22	88	52	34	G1/2	M22x1,5	79	120	41	14	166	1000
50	28/36	M22x1,5	22	M24x2	35	22/30	102	62	34	G1/2	M22x1,5	87	120	48.5	18	166	1000
63	36/45	M28x1,5	28	M30x2	45	30/36	120	78	42	G3/4	M27x2	100	133	56.5	22	166	2000
80	45/56	M35x1,5	35	M39x3	55	36/46	140	95	42	G3/4	M27x2	104	146	67	20	166	2000
100	56/70	M45x1,5	45	M50x3	75	46/60	170	125	47	G1	M33x2	124	171	82	30	166	3000
125	70/90	M58x1,5	58	M64x3	95	60/75	206	150	58	G1 1/4	M42x2	135	205	99	32	166	3000
140	90/100	M65x1,5	65	M80x3	110	75/85	226	170	58	G1 1/4	M42x2	156	219	109.5	35	166	3000
160	100/110	M80x2	80	M90x3	120	85/95	265	190	65	G1 1/2	M48x2	185	240	129	40	166	3000
180	110/125	M100x2	100	M100x3	140	95/110	292	210	65	G1 1/2	M48x2	199	264	142.5	40	166	3000
200	125/140	M110x2	110	M110x4	150	110/120	310	235	65	G1 1/2	M48x2	205	278	152	40	166	3000
220	140/160	M120x3	120	M120x4	160	120/140	355	273	65	G1 1/2	M48x2	242	326	174	40	166	3000
250	160/180	M120x3	120	M120x4	160	140/160	395	305	65	G1 1/2	M48x2	266	326	194	40	166	3000
280	180/200	M130x3	130	M150x4	190	160/180	425	343	65	G1 1/2	M48x2	282	375	210	40	166	3000
320	200/220	-	-	M160x4	200	180/200	490	394	65	G1 1/2	M48x2	287	431	243	40	166	3000

ØAL	ØMM	XS	ZB	SS	X* min	S	S1	ØSB H13	ST	TS js13	US max	LH	L1 12)	ØRA	VE	D1 max
40	28	114	235	50	-	30	15	11	32	110	140	45	93	52	40	80
50	28/36	124.5	243	45	-	35	17.5	11	37	130	161	55	110	65	40	96
63	36/45	142	287	49	-	40	20	13.5	42	150	183	65	129	75	45	96
80	45/56	151	312	52	2	50	25	17.5	47	180	220	75	149	95	45	96
100	56/70	179	352	61	3	60	30	22	57	210	260	90	181	115	55	96
125	70/90	200	392	75	-	70	35	26	67	255	313	105	215	135	60	96
140	90/100	230.5	430	70	19	85	42.5	30	72	290	359	115	235	155	70	96
160	100/110	272.5	475	65	44	105	52.5	33	77	330	402	135	277	200	80	96
180	110/125	296.5	515	69	50	115	57.5	40	92	360	445	150	305	220	90	96
200	125/140	307.5	535	73	56	125	62.5	40	97	385	471	160	322	235	95	96
220	140/160	367.5	635	75	100	155	77.5	45	102	445	541	185	373	270	115	96
250	160/180	391.5	659	75	100	155	77.5	52	112	500	610	205	414	300	125	96
280	180/200	407.5	744	124	171	155	77.5	52	127	530	641	225	449	325	130	96
320	200/220	440	815	125	85	190	95	62	142	610	732	255	512	365	155	96

ØAL = piston Ø

ØMM = piston rod Ø

X* = stroke length

X*max = max. stroke length

X*min = min. stroke length

With hydraulic cylinders with end position cushioning, observe the notice on page 68!

1) Bleeding: With view to the piston rod, the position is offset by 90° in relation to the line connection (clockwise)

2) Ø D4 max. 0.5 mm deep

3) Throttle valve only with end position cushioning "E" (180° for bleeding)

4) Flange connections see separate table pages 42 and 43

5) Thread design "G"

6) Thread design "A"

9) Observe the min. stroke length "X*min"

10) Recess 2 mm deep, for hexagon socket head cap screws; ISO 4762 – The screws must not be subjected to shear force. Force distribution via additional external fitting strip

16) Line connection "B" and "C"

17) Line connection "M"

Dimensions: Flange ports
 (dimensions in mm)

CDH1/CSH1

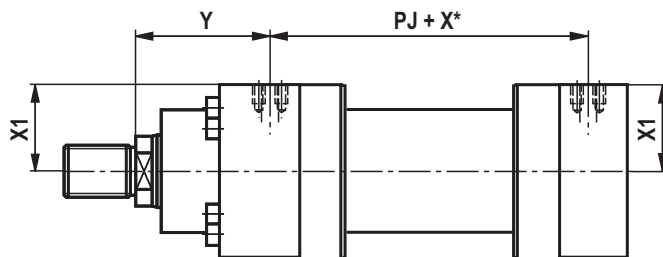

CGH1

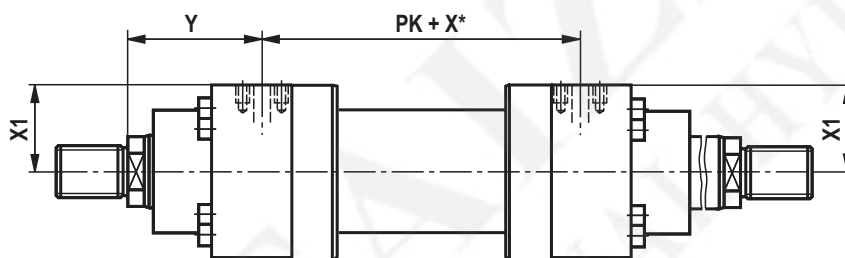

Hole pattern for rectangular flange according to
 ISO 6162-2 table 2 type 1

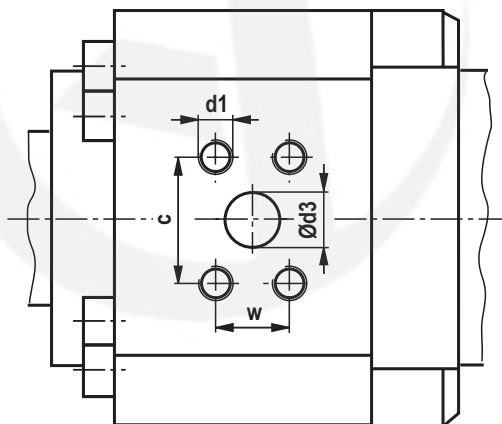

Hole pattern for square flange according to
 ISO 6164 table 2

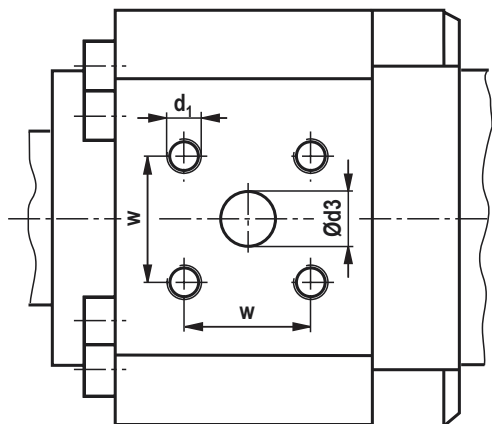

Dimensions: Flange ports
 (dimensions in mm)

ØAL	Version "D" ISO 6162-2 tab.2 type1 (400 bar) (≅ SAE 6000 PSI)											Version "H" ISO 6164 tab.2 (400 bar)								
	Y	PJ PK	X1	Ød ₃	Ød ₃ ⁴⁾	c ±0.25	w ±0.25	d ₁	t ₁ ¹⁾	t ₁ ²⁾	p ³⁾	Y	PJ PK	X1	Ød ₃	w ±0.25	d ₁	t ₁ ¹⁾	t ₁ ²⁾	p ³⁾
40	-	-	-	-	-	-	-	-	-	-	-	78	122	40.5	10	24.7	M6	12.5	10	400
50	-	-	-	-	-	-	-	-	-	-	-	86	122	48	10	24.7	M6	12.5	10	400
63	-	-	-	-	-	-	-	-	-	-	-	99	135	57	13	29.7	M8	16	13	400
80	102.5	149	65	13	1/2"	40.5	18.2	M8	16	14	400	103	148	67	13	29.7	M8	16	15	400
100	124	171	80.5	13	1/2"	40.5	18.2	M8	16	16	400	123	173	81.5	19	35.4	M8	16	16	400
125	135	205	97.5	19	3/4"	50.8	23.8	M10	20	20	400	131.5	212	99	25	43.8	M10	20	20	400
140	152	227	107	25	1"	57.2	27.8	M12	24	24	400	152	227	109	25	43.8	M10	20	20	400
160	184	242	127	25	1"	57.2	27.8	M12	24	24	400	182.5	245	128	32	51.6	M12	24	24	400
180	199	264	139.5	32	1 1/4"	66.6	31.8	M14	26	26	400	199	264	142	32	51.6	M12	24	24	400
200	205	278	149	32	1 1/4"	66.6	31.8	M14	26	26	400	201.5	285	149.5	38	60.1	M16	30	30	400
220	242	326	168	38	1 1/2"	79.3	36.5	M16	30	30	400	242	326	171	38	60.1	M16	30	30	400
250	266	326	189	38	1 1/2"	79.3	36.5	M16	30	30	400	266	326	192	38	60.1	M16	30	30	400
280	282	375	204	38	1 1/2"	79.3	36.5	M16	30	30	400	282	375	207	38	60.1	M16	30	30	400
320	287	431	236	51	2"	96.8	44.5	M20	36	36	400	287	431	240	51	69.3	M16	30	30	400

Main dimensions see pages 18 to 41

ØAL = piston Ø

X* = stroke length

1) Thread depth for seal design M, T, G, L, R, S and V

2) Thread depth for seal design A and B

3) Max. operating pressure for related flanges in bar

4) Flange hole pattern according to ISO 6162-2 tab. 2 type 1
 corresponds to flange hole pattern according to SAE 6000 PSI

Dimensions: Subplates for valve mounting (SL and SV valve)
 (dimensions in mm)

Note:

Valves, fittings and piping are **not** included in the scope of delivery!

 **Notice:** Subplates for SL and SV valves (check valves)
Please note:
 Seal designs T, G, L, R, S and V are not designed for static hold function!

Installation situation with MT4

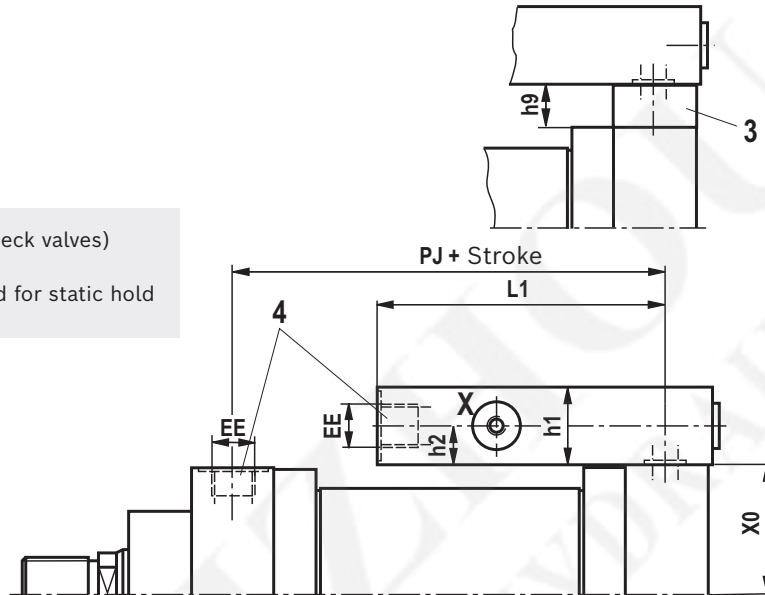

NG6

Hole pattern according to ISO 24340 form A and ISO 4401

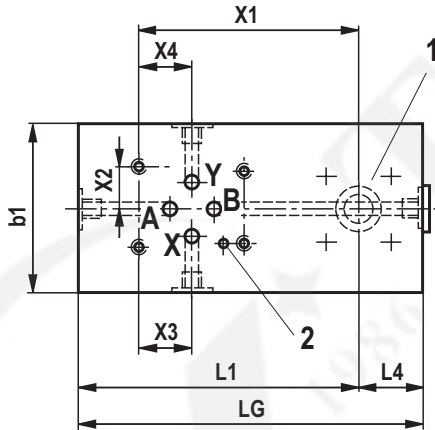

NG10 and 20

Hole pattern according to ISO 5781

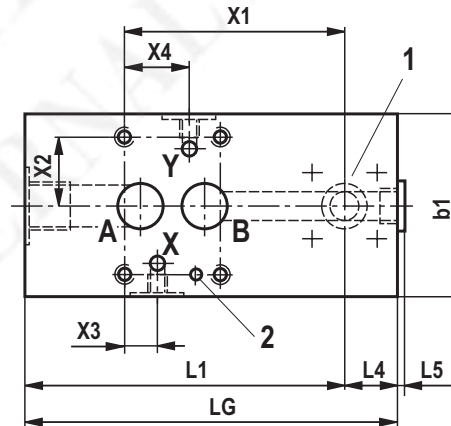

NG30

Hole pattern according to ISO 5781

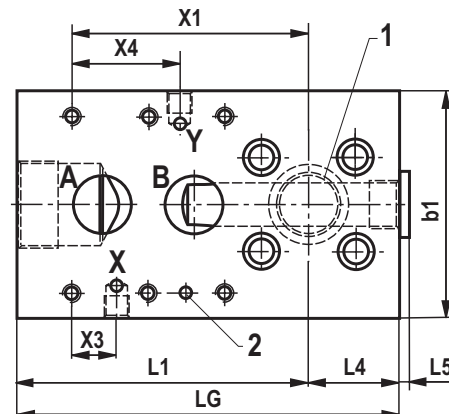

- 1 Port B to the piston side according to ISO 6164
- 2 Bore for locking pin
- 3 Adapter plate for type of mounting MT4 (included in the scope of delivery for MT4)
- 4 Line connection "B" dimensions "EE" see also pages 18 to 41

Dimensions: Subplates for valve mounting (SL and SV valve)
 (dimensions in mm)

ØAL	Valve size (NG)	PJ	EE	Stroke min ¹⁾		X0	Plate dimensions						Port size, hole pattern				Position point valve				
				2)	3)		L1	L4	L5	LG	b1	h1	h9	h2	A	X	Y	X3	X4	X1	X2
40	6	121	G1/2	50	50	40.5	90	20	4	110	55	40	10	20	G1/2	G1/4	G1/4	21.5	21.5	65.5	15.5
50	6	121	G1/2	50	50	48.0	90	20	4	110	55	40	10	20	G1/2	G1/4	G1/4	21.5	21.5	65.5	15.5
63	6	134	G3/4	64	64	57.0	100	25	5	125	55	47	20	23.5	G3/4	G1/4	G1/4	21.5	21.5	70.5	15.5
	10	134	G3/4	64	64	57.0	105	25	5	130	85	47	20	23.5	G3/4	G1/4	G1/4	21.4	21.4	73	33.3
80	6	147	G3/4	58	58	67.0	100	25	5	125	55	47	20	23.5	G3/4	G1/4	G1/4	21.5	21.5	70.5	15.5
	10	147	G3/4	58	58	67.0	105	25	5	130	85	47	20	23.5	G3/4	G1/4	G1/4	21.4	21.4	73	33.3
100	10	172	G1	50	79	81.5	102	28	5	130	85	50	20	25	G1	G1/4	G1/4	21.4	21.4	70	33.3
125	10	208.5	G1 1/4	60	91	99.0	115	35	5	150	85	60	30	30	G1 1/4	G1/4	G1/4	21.4	21.4	80	33.3
	20	208.5	G1 1/4	60	91	99.0	140	35	5	175	100	60	30	30	G1 1/4	G1/4	G1/4	20.8	39.7	95	39.7
140	10	223	G1 1/4	50	121	109.0	115	35	5	150	85	60	30	30	G1 1/4	G1/4	G1/4	21.4	21.4	80	33.3
	20	223	G1 1/4	50	121	109.0	140	35	5	175	100	60	30	30	G1 1/4	G1/4	G1/4	20.8	39.7	95	39.7
160	10	242.5	G1 1/2	60	142	128.0	120	40	5	160	85	70	30	35	G1 1/2	G1/4	G1/4	21.4	21.4	90	33.3
	20	242.5	G1 1/2	60	142	128.0	135	50	5	185	100	70	30	35	G1 1/2	G1/4	G1/4	20.8	39.7	105	39.7
	30	242.5	G1 1/2	60	142	128.0	160	50	5	210	125	70	30	35	G1 1/2	G1/4	G1/4	24.6	59.6	130	48.4
180	10	264	G1 1/2	50	158	142.0	120	40	5	160	85	70	30	35	G1 1/2	G1/4	G1/4	21.4	21.4	90	33.3
	20	264	G1 1/2	50	158	142.0	135	50	5	185	100	70	30	35	G1 1/2	G1/4	G1/4	20.8	39.7	105	39.7
	30	264	G1 1/2	50	158	142.0	160	50	5	210	125	70	30	35	G1 1/2	G1/4	G1/4	24.6	59.6	130	48.4
200	10	281.5	G1 1/2	30 ⁴⁾	194	149.5	130	45	5	175	95	70	20	35	G1 1/2	G1/4	G1/4	21.4	21.4	100	33.3
	20	281.5	G1 1/2	30 ⁴⁾	194	149.5	140	45	5	185	100	70	20	35	G1 1/2	G1/4	G1/4	20.8	39.7	115	39.7
	30	281.5	G1 1/2	30 ⁴⁾	194	149.5	165	45	5	210	125	70	20	35	G1 1/2	G1/4	G1/4	24.6	59.6	140	48.4

ØAL = piston Ø

¹⁾ The information only applies to the following connection situation!

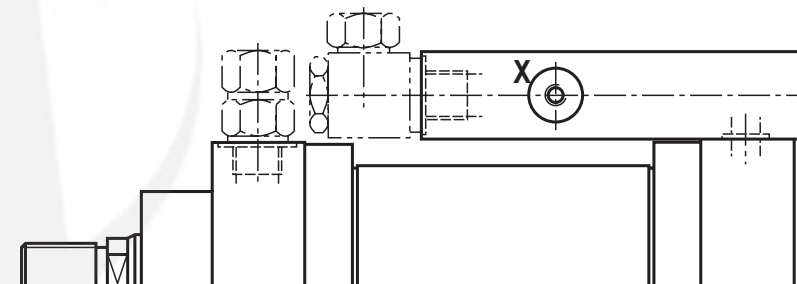

²⁾ Not for MT4

³⁾ Only for MT4

⁴⁾ With type of mounting "MS2". observe X*min on page 28 and/or 40

Dimensions: Subplates for valve mounting (directional and control valves)
 (dimensions in mm)

Installation situation with MT4

- 1 Port A to the piston side according to ISO 6164
- 2 Bore for locking pin
- 3 Adapter plate for type of mounting MT4 (included in the scope of delivery for MT4)
- 4 Connection "B" dimensions "EE" see also pages 18 to 41

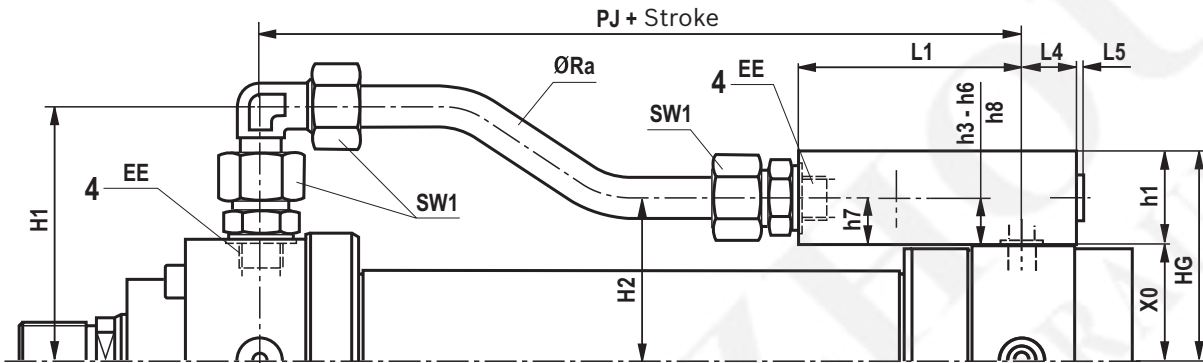
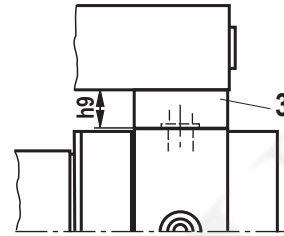

NG6
 Hole pattern according to ISO 24340 form A and ISO 4401

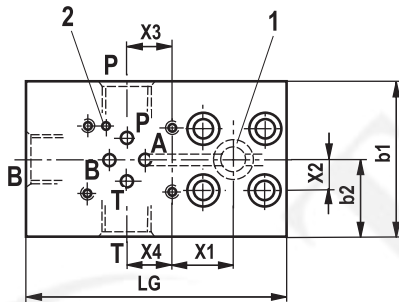

NG10
 Hole pattern according to ISO 24340 form A and ISO 4401

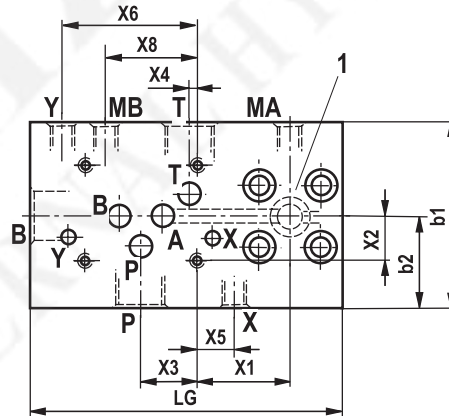

NG16
 Hole pattern according to ISO 24340 form A and ISO 4401

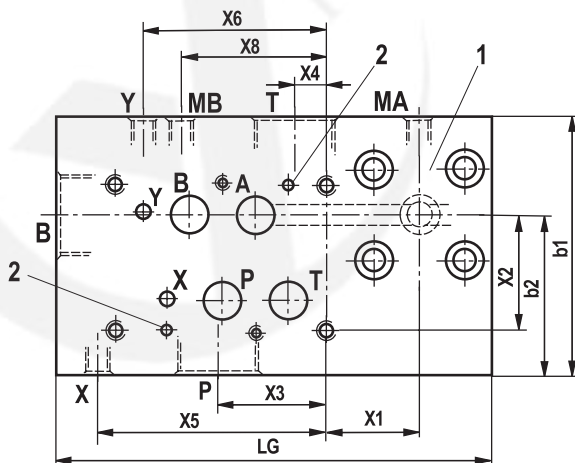

NG25
 Hole pattern according to ISO 24340 form A and ISO 4401

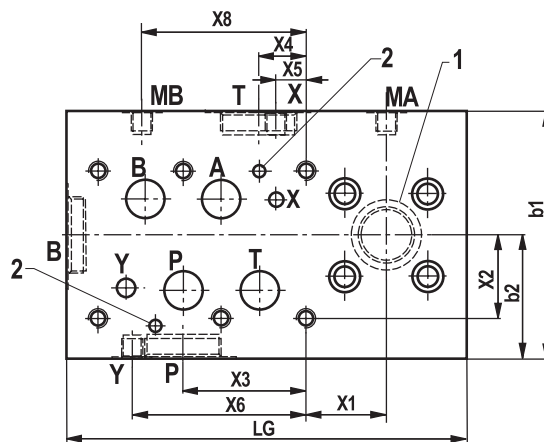

With larger stroke lengths and depending on the piston diameter, the pipeline is mounted at the cylinder pipe using pipe supports. A maximum of two sandwich plates is admissible. 46

Dimensions: Subplates for valve mounting (directional and control valves)
(dimensions in mm)

ØAL	Valve size (NG)	PJ	EE	Stroke min	Plate dimensions																
					L1	L4	L5 max	H1	H2 ¹⁾	H2 ²⁾	SW1	ØRa	b1	h1	LG	HG ¹⁾	HG ²⁾	b2	X0	h7	h9
40	6	121	G1/2	242	90	20	4	96.0	60.5	70.5	30	16.0x2.5	65	40	110	80.5	90.5	32.5	40.5	20	10
50	6	121	G1/2	242	90	20	4	103.5	68.0	78.0	30	16.0x2.5	65	40	110	88.0	98.0	32.5	48.0	20	10
63	6	134	G3/4	276	100	25	5	121.5	80.5	100.5	36	20.0x3.0	75	47	125	104.0	124.0	37.5	57.0	23.5	20
	10	134	G3/4	301	125	25	5	121.5	80.0	100.0	36	20.0x3.0	90	70	150	127.0	147.0	45	57.0	23	20
80	6	147	G3/4	263	100	25	5	132.0	90.5	110.5	36	20.0x3.0	75	47	125	114.0	134.0	37.5	67.0	23.5	20
	10	147	G3/4	288	125	25	5	132.0	90.0	110.0	36	20.0x3.0	90	70	150	137.0	157.0	45	67.0	23	20
100	10	172	G1	317	132	28	5	155.0	111.5	131.5	46	25.0x4.0	90	80	160	161.5	181.5	45	81.5	30	20
125	10	208.5	G1 1/4	330	135	35	5	177.5	134.0	164.0	50	30.0x5.0	105	95	170	194.0	224.0	52.5	99.0	35	30
	16	208.5	G1 1/4	370	175	35	5	177.5	144.0	174.0	50	30.0x5.0	120	100	210	199.0	229.0	60	99.0	45	30
140	10	223	G1 1/4	315	135	35	5	188.0	144.0	174.0	50	30.0x5.0	105	95	170	204.0	234.0	52.5	109.0	35	30
	16	223	G1 1/4	355	175	35	5	188.0	154.0	184.0	50	30.0x5.0	120	100	210	209.0	239.0	60	109.0	45	30
160	10	242.5	G1 1/2	399	150	40	5	218.0	163.0	193.0	60	38.0x6.0	105	95	190	223.0	253.0	52.5	128.0	35	30
	16	242.5	G1 1/2	429	180	40	5	218.0	178.0	208.0	60	38.0x6.0	125	105	220	233.0	263.0	62.5	128.0	50	30
	25	242.5	G1 1/2	449	200	50	0	218.0	183.0	213.0	60	38.0x6.0	155	110	250	238.0	268.0	77.5	128.0	55	30
180	10	264	G1 1/2	377	150	40	5	231.5	177.0	207.0	60	38.0x6.0	105	95	190	237.0	267.0	52.5	142.0	35	30
	16	264	G1 1/2	407	180	40	5	231.5	192.0	222.0	60	38.0x6.0	125	105	220	247.0	277.0	62.5	142.0	50	30
	25	264	G1 1/2	427	200	50	0	231.5	197.0	227.0	60	38.0x6.0	155	110	250	252.0	282.0	77.5	142.0	55	30
200	10	281.5	G1 1/2	365	155	50	5	241.0	184.5	204.5	60	38.0x6.0	110	95	205	244.5	264.5	55	149.5	35	20
	16	281.5	G1 1/2	400	190	50	5	241.0	199.5	219.5	60	38.0x6.0	125	105	240	254.5	274.5	62.5	149.5	50	20
	25	281.5	G1 1/2	420	210	50	0	241.0	204.5	224.5	60	38.0x6.0	155	110	260	259.5	279.5	77.5	149.5	55	20

ØAL	Valve size (NG)	Port size, hole pattern																Position point valve	
		P	X3	h3	T	X4	h4	X	X5	h5	Y	X6	h6	MA	MB	X8	h8	X1	X2
40	6	G1/2	21.5	20	G1/2	21.5	20	-	-	-	-	-	-	-	-	-	-	25	15.5
50	6	G1/2	21.5	20	G1/2	21.5	20	-	-	-	-	-	-	-	-	-	-	25	15.5
63	6	G3/4	21.5	23.5	G3/4	21.5	23.5	-	-	-	-	-	-	-	-	-	-	30	15.5
	10	G3/4	27	33	G3/4	3.5	33	G1/4	18	47	G1/4	65.0	47	G1/4	G1/4	60	17	45	21.4
80	6	G3/4	21.5	23.5	G3/4	21.5	23.5	-	-	-	-	-	-	-	-	-	-	30	15.5
	10	G3/4	27	33	G3/4	3.5	33	G1/4	18	47	G1/4	65.0	47	G1/4	G1/4	60	17	45	21.4
100	10	G1	27	30	G1	3.5	40	G1/4	18	57	G1/4	65.0	57	G1/4	G1/4	58	20	52	21.4
125	10	G1 1/4	27	35	G1 1/4	3.5	45	G1/4	20	72	G1/4	65.0	72	G1/4	G1/4	55	25	55	21.4
	16	G1 1/4	52	32	G1 1/4	15	32	G1/4	76.5	75	G1/4	88.0	80	G1/4	G1/4	88	40	45	40
140	10	G1 1/4	27	35	G1 1/4	3.5	45	G1/4	20	72	G1/4	65.0	72	G1/4	G1/4	55	25	55	21.4
	16	G1 1/4	52	32	G1 1/4	15	32	G1/4	76.5	75	G1/4	88.0	80	G1/4	G1/4	88	40	45	40
160	10	G1 1/2	27	35	G1 1/2	3.5	45	G1/4	20	72	G1/4	65.0	72	G1/4	G1/4	55	25	60	21.4
	16	G1 1/2	57	35	G1 1/2	15	34	G1/4	76.5	80	G1/4	86.0	85	G1/4	G1/4	86	45	50	40
	25	G1 1/2	77	42	G1 1/2	30	34	G1/4	19	90	G1/4	109.0	90	G1/4	G1/4	103	50	50	52.1
180	10	G1 1/2	27	35	G1 1/2	3.5	45	G1/4	20	72	G1/4	65.0	72	G1/4	G1/4	55	25	60	21.4
	16	G1 1/2	57	35	G1 1/2	15	34	G1/4	76.5	80	G1/4	86.0	85	G1/4	G1/4	86	45	50	40
	25	G1 1/2	77	42	G1 1/2	30	34	G1/4	19	90	G1/4	109.0	90	G1/4	G1/4	103	50	50	52.1
200	10	G1 1/2	27	35	G1 1/2	3.5	45	G1/4	19	72	G1/4	62.0	72	G1/4	G1/4	50	25	72	21.4
	16	G1 1/2	57	35	G1 1/2	15	34	G1/4	76.5	80	G1/4	86.0	85	G1/4	G1/4	86	45	60	40
	25	G1 1/2	77	42	G1 1/2	30	34	G1/4	19	90	G1/4	109.0	90	G1/4	G1/4	103	50	60	52.1

ØAL = piston Ø

¹⁾ Not for MT4

²⁾ Only for MT4

Bleeding / measuring coupling
 (dimensions in mm)

By default, a patented safety vent against unintended unscrewing in head and base is delivered for all cylinders. The port allows for the installation of a measuring coupling

with check valve for pressure measurement or contamination-free bleeding. Measuring coupling with check valve function, i.e. the measuring or bleeding hose can also be connected when the system is pressurized.

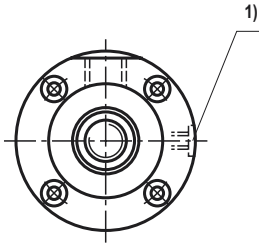

1) Bleeding: With view to the piston rod, the position is offset by 90° in relation to the line connection (clockwise)

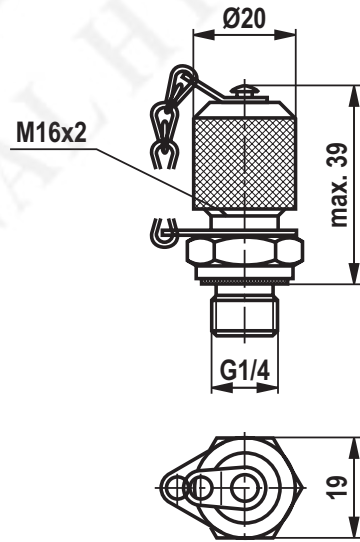
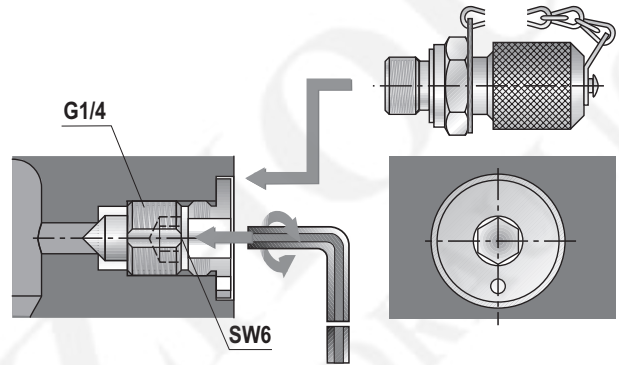

Scope of delivery: Measuring coupling **G1/4**

MEASURING COUPLING AB 20-11/K1 G1/4 with seal ring made of NBR

Material no. **R900009090**

MEASURING COUPLING AB 20-11/K1V G1/4 with seal ring made of FKM

Material no. **R900001264**

Dimensions: Throttle valve
 (dimensions in mm)

ØAL	40	50	63	80	100	125	140	160	180	200	220	250	280	320
Protrusion A 1)	1	0	0	0	0	0	0	0	0	0	9.5	0	0	0
Nominal width	4	4	4	5	5	8	8	8	8	8	20	20	20	20

ØAL = piston Ø

1) Throttle valve only with end position cushioning "E"
 (180° for bleeding) Protrusion A in closed condition

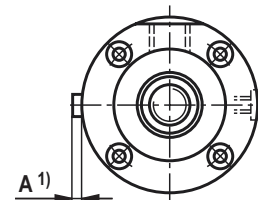

Proximity switch (dimensions in mm)

Inductive proximity switches are used as reliable end position control for hydraulic cylinders. They are an important element for the safe and exact monitoring of safety equipment, lockings and/or other machine functions in their end position by means of the output of signals. The proximity switch which is high-pressure-resistant up to 500 bar works in a contactless manner.

Consequently, it is wear-free. The proximity switch has been set at the factory. The switching distance must not be adjusted. The lock nut of the proximity switch is marked at the factory using sealing wax. On versions with proximity switch, the cylinders are provided with proximity switches on both sides.

Technical data

(For applications outside these values, please consult us!)

Electrical		
Function type		PNP normally open contact
Admissible pressure	bar	500
Operating voltage	V DC	10 ... 30
	including residual ripple	% ≤ 15
Voltage drop	V	≤ 15
Rated operating voltage	V DC	24
Rated operating current	mA	200
Idle current	mA	≤ 8
Residual current	µA	≤ 10
Repetition accuracy	%	≤ 5
Hysteresis	%	≤ 15
Ambient temperature range	°C	-25 ... +80
Temperature drift	%	≤ 10
Switching frequency	Hz	1000
Protection class according to DIN EN 60529	▶ Active area	IP68
	▶ Proximity switch	IP67
Housing material		Material no. 1.4104

Pin assignment

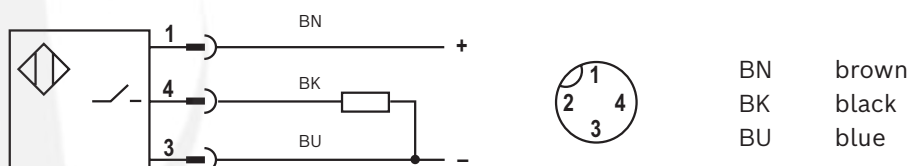

Dimensions: Proximity switch
 (dimensions in mm)

CDH1

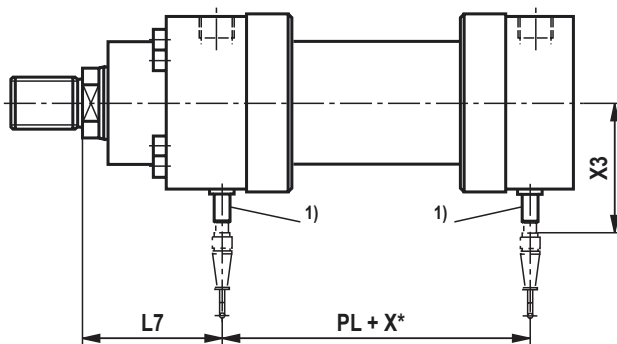

CGH1

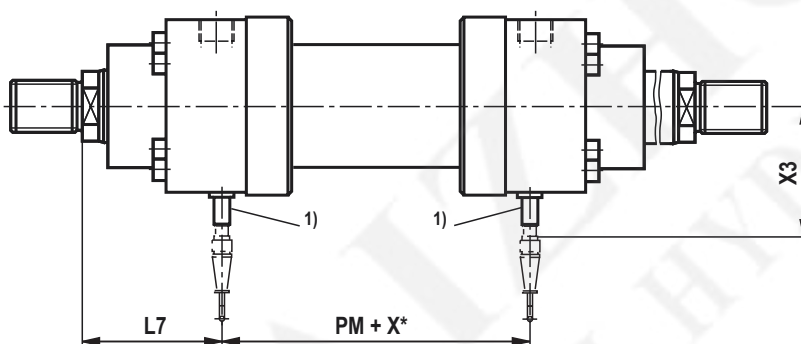

Installation space for mating connector

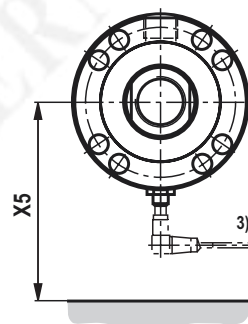
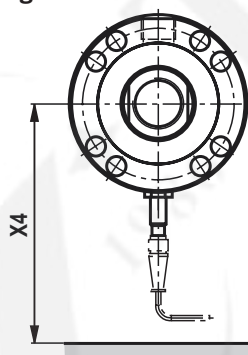

Mating connector with 5 m cable

Material no. **R913016852**

(mating connector is **not** included in the scope of delivery, must be ordered separately)



Mating connector, angled with 5 m cable

(position of the cable outlet cannot be defined)

Material no. **R988064311**

(mating connector is **not** included in the scope of delivery, must be ordered separately)

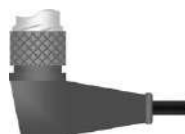

Dimensions: Proximity switch
 (dimensions in mm)

ØAL	ØMM	PL	PM	L7	X3	X4	X5
40	22 28	112	112	83	94	170	125
50	28 36	110	110	92	98	175	130
63	36 45	125	125	104	103	180	135
80	45 56	138	138	108	108	185	140
100	56 70	161	161	129	116	195	150
125	70 90	189	189	143	126	205	160
140	90 100	209	209	161	146	225	180
160	100 110	228	228	191	151	230	185
180	110 125	254	254	204	159	235	190
200	125 140	264	264	212	166	245	200
220	140 160	310	310	250	177 ²⁾	255	- ³⁾
250	160 180	310	310	274	187 ²⁾	265	- ³⁾
280	180 200	369	369	285	189 ²⁾	275	- ³⁾
320	200 220	415	415	295	209 ²⁾	285	- ³⁾

Main dimensions see page 18 to 29

ØAL = piston Ø
 ØMM = piston rod Ø
 X* = stroke length

- 1) The proximity switch is always located opposite of the line connection
- 2) Piston Ø 220 - 320 mm
 Proximity switch not protruding
- 3) Piston Ø 220 - 320 mm
 Angled mating connector not possible

Position measurement system

The magnetostrictive position measurement system that is pressure-resistant and works contactless and absolute.

Operating conditions	
Protection class	IP67 (connector professionally mounted) IP68 at cable outlet
EMC test	Electro-magnetic interference emission according to EN 61000-6-3 Electro-magnetic interference resistance according to EN 61000-6-2 The sensor complies with EC directives and bears the CE marking

Technical data: Analog output

(For applications outside these values, please consult us!)

Analog "F" / "C"			
Electrical connection	Type of connection	1 x M16 connector (6-pole)	
	Power consumption	W	<3.25
Operating conditions	Operating temperature	°C	-40 ... +85
Tightening torque M_A	≤ 1500 mm measurement length	Nm	50 ±4%
	> 1500 mm measurement length	Nm	65 ±4%
Wrench size SW		mm	46
Voltage "F"		V	0 ... 10
	Input resistance control system	kΩ	>5
	Resolution		16 bit (internal resolution 0.1 μm)
Current "C"		mA	4 ... 20
	Load	Ω	min/max: 0/500
	Resolution		16 bit (internal resolution 0.1 μm)

Connector
 (View to pin side)

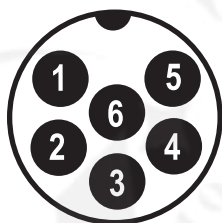

Pin	Cable	Function
1	gray	Position 1 (solenoid)
2	pink	DC ground
3	yellow	not used
4	green	DC ground
5	brown	+12 ... 30 VDC ±20% (9.6 ... 36 VDC)
6	white	DC ground (0 V)

Technical data: Digital output
 (For applications outside these values, please consult us!)

Digital "D" / "S"			
Electrical connection	Type of connection	1 x M16 connector (7-pole)	
	Power consumption	W	1.2 typical
Operating conditions	Operating temperature	°C	-40 ... +85
Tightening torque M_A	≤ 1500 mm measurement length	Nm	50 ±4%
	> 1500 mm measurement length	Nm	65 ±4%
Wrench size SW		mm	46
SSI "D"	Interface	SSI 24 bit (RS-485/RS-422)	
	Resolution	μm	5
	Direction of measurement	asynchronous forward	
	Data format	Gray	
SSI "S"	Interface	SSI 24 bit (RS-485/RS-422)	
	Resolution	μm	1
	Direction of measurement	synchronous forward	
	Data format	Gray	

Connector
 (View to pin side)

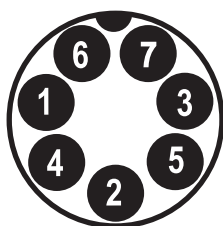

Pin	Cable	Function
1	gray	Data (-)
2	pink	Data (+)
3	yellow	Clock (+)
4	green	Clock (-)
5	brown	+12 ... 30 VDC ±20% (9.6 ... 36 VDC)
6	white	DC ground (0 V)
7	-	not used

Types of mounting
MP3, MP5

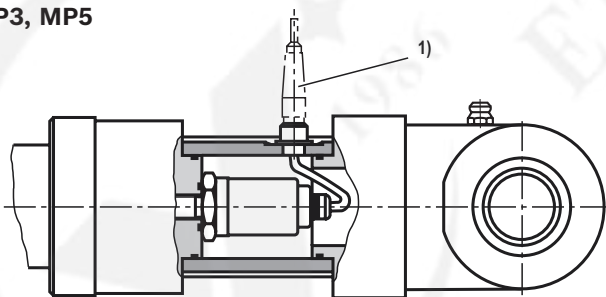

1) For analog output:
 6-pole amphenol mating connector, material no. R900072231
 (mating connector is **not** included in the scope of delivery,
 must be ordered separately)



MF3, MF4, MT4, MS2

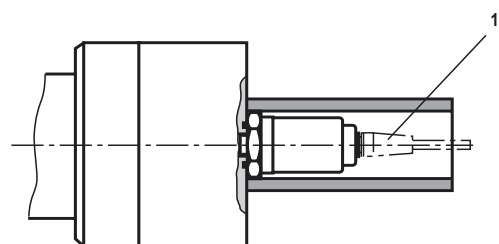

1) For digital output:
 7-pole amphenol mating connector, material no. R900079551
 (mating connector is **not** included in the scope of delivery,
 must be ordered separately)



Technical data: Profibus
 (For applications outside these values, please consult us!)

Profibus "N" / "P"		Profibus 63 / Profibus 53	
Electrical connection	Type of connection		2 x M16 connector (6-pole), alternatively 2 x M12 connector (5-pole) and 1 x M8 connector (4-pole)
	Current consumption	mA	90, typical
Operating conditions	Operating temperature	°C	-40 ... +75
	Tightening torque M_A	Nm	65 ±4%
	Wrench size SW	mm	46
Output	Interface		IEC 61158 CPF3 PROFIBUS
	Data record		PROFIBUS-DP slave
	Transmission rate	MBit/s	max. 12
Measurement accuracy	Travel resolution	µm	1 ... 1000 selectable as parameter
	Velocity		With 5 µm travel resolution: 0.64 mm/s to 500 mm; 0.43 mm/s to 2000 mm; 0.21 mm/s to 4500 mm; 0.14 mm/s to 7600 mm measurement length With 2 µm travel resolution: 2.5 times smaller values
	Linearity		< ± 0.01% Full Scale (Minimum +/- 50 µm)
	Repeatability		< ± 0.001% Full Scale (Minimum +/- 2.5 µm)
	Temperature coefficient	ppm/°C	< 15
	Hysteresis	µm	< 4

Pin assignment for Profibus

Pin assignment for Profibus D63

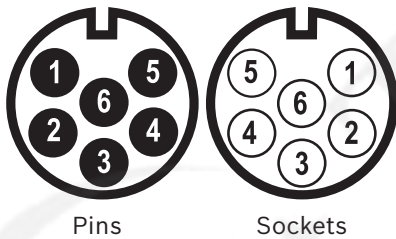

Pin	Cable	Function
1	green	RxD/TxD-N (bus)
2	red	RxD/TxD-P (bus)
3	--	DGND (terminating resistor) *
4	--	VP (terminating resistor) *
5	black	+24 V DC (-15 / +20%)
6	blue	DC ground (0 V)
--	yellow/green	Shield compensating line, is usually not to be connected

* only with sockets

Pin assignment for Profibus D53

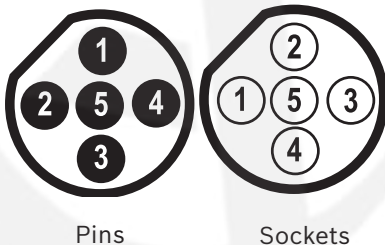

Pin	Cable	Function
1	--	VP+5 (terminating resistor) *
2	green	RxD/TxD-N (bus)
3	--	DGND (terminating resistor) *
4	red	RxD/TxD-P (bus)
5	Shield	Shield

* only with sockets

Supply

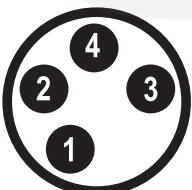

Pin	Cable	Function
1	brown	+24 V DC (-15 / +20%)
2	white	not used
3	blue	DC ground (0 V)
4	black	not used

View connector side

Types of mounting

MP3, MP5

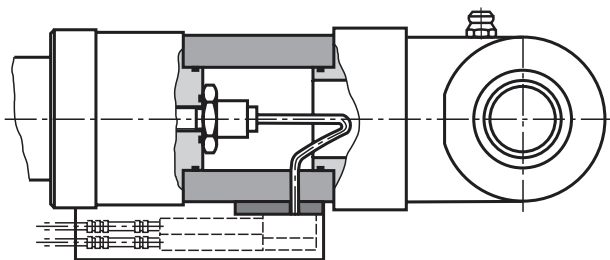

MF3, MF4, MT4, MS2

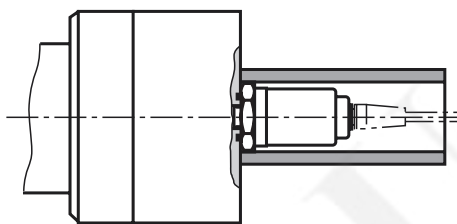

The output of the position measurement system is by default always rotated by 180° to the selected position of the hydraulic connection in the cylinder base.

Mating connectors for D63



Signal input
 6-pole mating connector M16
 Material no. R900705950 (socket)



Signal output
 6-pole end plug M16
 Material no. R900722518 (pins)



Signal output
 6-pole mating connector M16
 Material no. R900705951 (pins)

Mating connectors for D53



Signal input
 5-pole mating connector M12-B
 Material no. R900773386 (socket)



4-pole mating connector M8
 Material no. R901132799



Signal output
 5-pole mating connector M12-B
 Material no. R901091655 (pins)



Connection cable 5 m with
 4-pole mating connector M8
 Material no. R901213191



Signal output
 5-pole end plug M12-B
 Material no. R901070126 (pins)

Connection cable 10 m with
 4-pole mating connector M8
 Material no. R913008737

Connection cable 15 m with
 4-pole mating connector M8
 Material no. R913008738

Mating connector is **not** included in the scope of delivery, must be ordered separately.

Technical data: IO-Link

(For applications outside these values, please consult us!)

IO-Link "L"		IO-Link V1.1	
Electrical connection	Type of connection	1 x M12 connector (4-pole)	
	Operating voltage	VDC	+24 (± 25%) / residual ripple ≤ 0.28 Vpp
	Current consumption	mA	< 50
Operating conditions	Operating temperature	°C	-40 ... +75
Tightening torque M _A		Nm	50 ±4%
Wrench size SW		mm	34
Output	Interface	Digital	
	Transmission record	IO-Link V1.1	
	Data format	Bit	32 signed (position in μm)
	Data transmission rate	COM3 (230.4 kBaud)	
	Process data Device - Master	Bytes	4
	Process data Master - Device	Bytes	0
	Measured variable	MBit/s	Position
Measured values	Resolution ¹⁾	μm	5; 10; 20; 50 or 100
	Cycle time:	ms	Minimum 1 (depending on master)
	Linearity ²⁾	%	≤ ±0.02 F.S. (Minimum ±60 μm)
	Measurement repetition accuracy	%	≤ ±0.005 F.S. (Minimum ±20 μm)

1) Selectable via IO-Link Master.

2) Tested with position magnet 251 416-2.

M12 connector (A-coded)

View to sensor



Pin	Function
1	+ 24 VDC (± 25%)
2	DI / DQ
3	DC ground (0 V)
4	C / Q

Mating connectors



M12 A-coded (5-pole), straight

Material number: R913045873

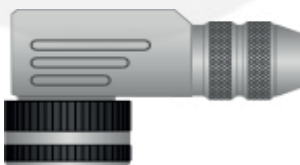

M12 A-coded (5-pole), angled

Material number: R901500328

Mating connector is **not** included in the scope of delivery, must be ordered separately.

Technical data: Profinet
(For applications outside these values, please consult us!)

Profinet "R"		Profinet RT / Profinet IRT version 2.3						
Electrical connection	Type of connection	2 x M12 device socket (5-pole) 1 x M12 connector (4-pole)						
	Operating voltage	VDC	+12 ... 30 ($\pm 20\%$) (9.6 ... 36)					
	Power consumption	W	< 4 typical					
Operating conditions	Operating temperature	$^{\circ}\text{C}$	-40 ... +85					
Tightening torque M_A		Nm	65 $\pm 4\%$					
Wrench size SW		mm	46					
Output	Interface	Profinet RT						
		Profinet IRT version 2.3						
	Data record	MTS profile and encoder profile 4.1						
	Data transmission rate	MBit/s	max. 100					
Measured values	Resolution	μm	0,5 ... 100 (selectable)					
	Cycle time ¹⁾	Measurement length	mm	≤ 50	≤ 715	≤ 2000	≤ 4675	≤ 7620
			μs	250	500	1000	2000	4000
	Linearity deviation ²⁾	Measurement length	mm	≤ 500		> 500		
			μm	$\leq \pm 50$		$< 0.01\% \text{ F.S.}$		
	Measurement repetition accuracy	%	$\leq \pm 0.001 \text{ F.S.}$ (Minimum $\pm 2.5 \mu\text{m}$) typical					
	Hysteresis	μm	< 4 typical					
	Temperature coefficient	ppm/K	< 15 typical					

1) Sensor with standard settings

2) Tested with position magnet 251 416-2.

M12 device socket (D-coded)

Port 1 and 2 - signal
(View to sensor)

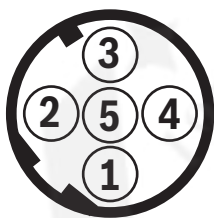

Pin	Function
1	Tx (+)
2	Rx (+)
3	Tx (-)
4	Rx (-)
5	Not used

M12 connector (A-coded)



Pin	Function
1	+12...30 VDC ($\pm 20\%$)
2	Not used
3	DC ground (0 V)
4	Not used

Technical data: Profinet

Types of mounting

MP3, MP5

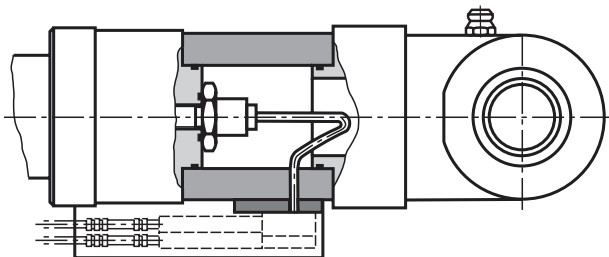

MF3, MF4, MT4, MS2

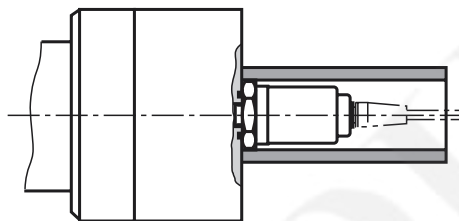

The output of the position measurement system is by default always rotated by 180° to the selected position of the hydraulic connection in the cylinder base.

Mating connectors



M12 D-coded (4-pole), straight

Material number: R913045872
(required 2 x)



M12 A-coded (5-pole), straight

Material number: R913045873

Mating connector is **not** included in the scope of delivery, must be ordered separately.

Plain clevis CSA
 (dimensions in mm)

ØAL 40-200 mm

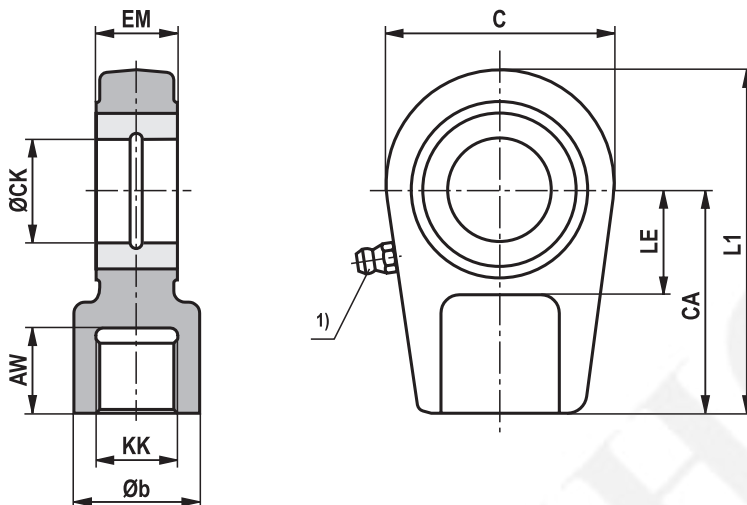

ØAL	Type	Material no.	AW	Øb	C	CA	ØCK H11	EM -0.4	KK	LE	L1	<i>m</i> ²⁾ kg	<i>C</i> ₀ ³⁾ kN	<i>F</i> _{adm} ⁴⁾ kN
40	CSA 16	R900303150	17	28	56	50	25	23	M16x1,5	25	80	0.43	72	25.9
50	CSA 22	R900303151	23	34	64	60	30	28	M22x1,5	30	94	0.7	106	38.2
63	CSA 28	R900303152	29	44	78	70	35	30	M28x1,5	40	112	1.1	153	55.1
80	CSA 35	R900303153	36	55	94	85	40	35	M35x1,5	45	135	2.0	250	90.0
100	CSA 45	R900303154	46	70	116	105	50	40	M45x1,5	55	168	3.3	365	131.4
125	CSA 58	R900303155	59	87	130	130	60	50	M58x1,5	65	200	5.5	400	144.0
140	CSA 65	R900303156	66	93	154	150	70	55	M65x1,5	75	232	8.6	540	194.4
160	CSA 80	R900303157	81	125	176	170	80	60	M80x2	80	265	12.2	670	241.2
180	CSA100	R900303158	101	143	206	210	90	65	M100x2	90	323	21.5	980	352.8
200	CSA110	R900303159	111	153	230	235	100	70	M110x2	105	360	27.5	1120	403.2

The specified dimensions are maximum values and may differ depending on the manufacturer.

The following values are excluded: CA, CK, EM, KK

The plain clevis must always be screwed against the shoulder of the piston rod and secured against loosening!

ØAL = piston Ø

1) Grease nipple, cone head form A according to DIN 71412

2) *m* = weight of plain clevis in kg

3) *C*₀ = static load rating of the plain clevis

4) *F*_{adm} = max. admissible load of the plain clevis for oscillatory or alternating loads

Swivel head CGA
(dimensions in mm)

ØAL 40-280 mm

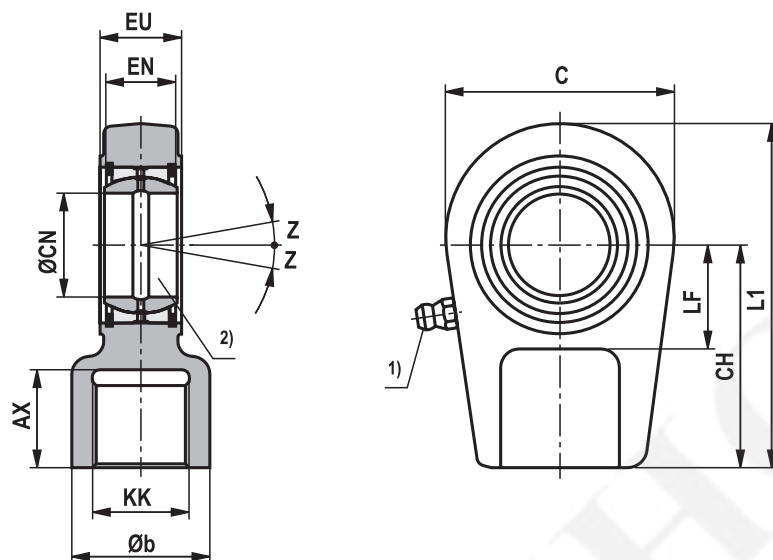

ØAL	Type	AX min	Øb max	C	CH	ØCN ²⁾	EN	EU -0.4	KK	L1	LF min	Z	m ³⁾ kg
40	CGA 16	17	26	56	50	25 _{-0.010}	20 _{-0.12}	23	M16x1,5	80	28	7 °	0.43
50	CGA 22	23	33	64	60	30 _{-0.010}	22 _{-0.12}	28	M22x1,5	94	30	6 °	0.7
63	CGA 28	29	41	78	70	35 _{-0.012}	25 _{-0.12}	30	M28x1,5	112	38	6 °	1.1
80	CGA 35	36	50	94	85	40 _{-0.012}	28 _{-0.12}	35	M35x1,5	135	45	7 °	2.0
100	CGA 45	46	62	116	105	50 _{-0.012}	35 _{-0.12}	40	M45x1,5	168	55	6 °	3.3
125	CGA 58	59	76	130	130	60 _{-0.015}	44 _{-0.15}	50	M58x1,5	200	65	6 °	5.5
140	CGA 65	66	87	154	150	70 _{-0.015}	49 _{-0.15}	55	M65x1,5	232	75	6 °	8.6
160	CGA 80	81	106	176	170	80 _{-0.015}	55 _{-0.15}	60	M80x2	265	80	6 °	12.2
180	CGA100	101	125	206	210	90 _{-0.020}	60 _{-0.20}	65	M100x2	323	90	5 °	21.5
200	CGA110	111	139	230	235	100 _{-0.020}	70 _{-0.20}	70	M110x2	360	105	7 °	27.5
220	CGA120	125	153	265	265	110 _{-0.020}	70 _{-0.20}	80	M120x3	407.5	115	6 °	40.7
250	CGA120	125	153	265	265	110 _{-0.020}	70 _{-0.20}	80	M120x3	407.5	115	6 °	40.7
280	CGA130	135	173	340	310	120 _{-0.020}	85 _{-0.20}	90	M130x3	490	140	6 °	76.4

ØAL	Type	Material no. requiring maintenance	Material no. maintenance-free	C ₀ ⁴⁾ kN	F _{adm} ⁵⁾ kN
40	CGA 16	R900303125	R900322702	72	35.9
50	CGA 22	R900303126	R900321695	106	38.2
63	CGA 28	R900303127	R900321653	153	55.1
80	CGA 35	R900303128	R900321694	250	90.0
100	CGA 45	R900303129	R900321667	365	131.4
125	CGA 58	R900303130	R900321693	400	144.0
140	CGA 65	R900303131	R900323345	540	194.4
160	CGA 80	R900303132	R900321669	670	241.2
180	CGA100	R900303133	R900323349	980	352.8
200	CGA110	R900303134	R900868406	1120	403.2
220	CGA120	R900303135	R900321668	1700	612.0
250	CGA120	R900303135	R900321668	1700	612.0
280	CGA130	R900303136	On request	2900	1044.0

The specified dimensions are maximum values and may differ depending on the manufacturer.

The following values are excluded: CH, CN, EN, EU, KK

The swivel head must always be screwed against the shoulder of the piston rod and secured against loosening!

ØAL = piston Ø

1) Grease nipple, cone head form A according to DIN 71412; not applicable to spherical bearing, maintenance-free "A"

2) Related bolt Ø m6; Related bolt Ø j6 with maintenance-free spherical bearing

3) m = weight of swivel head in kg

4) C₀ = static load rating of the swivel head

5) F_{adm} = max. admissible load of the swivel head with oscillatory or alternating loads

Swivel head CGAK (clampable)

(dimensions in mm)

ØAL 40-280 mm

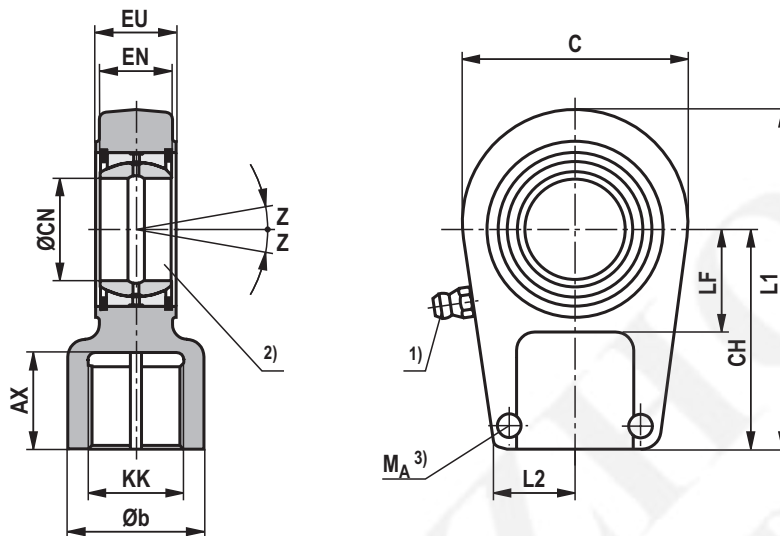

ØAL	Type	Material no. requiring maintenance	Material no. maintenance-free	C_0 ⁴⁾ kN	F_{adm} ⁵⁾ kN	AX min	Øb max	C	CH	ØCN ²⁾	EN	EU -0.4	KK
40	CGAK 16	R900303162	R900321784	72	35.9	17	26	56	50	25 _{-0.010}	20 _{-0.12}	23	M16x1,5
50	CGAK 22	R900303163	R900321683	106	38.2	23	33	64	60	30 _{-0.010}	22 _{-0.12}	28	M22x1,5
63	CGAK 28	R900303164	R900300717	153	55.1	29	41	78	70	35 _{-0.012}	25 _{-0.12}	30	M28x1,5
80	CGAK 35	R900303165	R900322738	250	90.0	36	50	94	85	40 _{-0.012}	28 _{-0.12}	35	M35x1,5
100	CGAK 45	R900303166	R900322019	365	131.4	46	62	116	105	50 _{-0.012}	35 _{-0.12}	40	M45x1,5
125	CGAK 58	R900303167	R900322020	400	144.0	59	76	130	130	60 _{-0.015}	44 _{-0.15}	50	M58x1,5
140	CGAK 65	R900303168	R900324812	540	194.4	66	87	154	150	70 _{-0.015}	49 _{-0.15}	55	M65x1,5
160	CGAK 80	R900303169	R900541157	670	241.2	81	106	176	170	80 _{-0.015}	55 _{-0.15}	60	M80x2
180	CGAK100	R900321655	R900323305	980	352.8	101	125	206	210	90 _{-0.020}	60 _{-0.20}	65	M100x2
200	CGAK110	R900321691	R900329997	1120	403.2	111	139	231	235	100 _{-0.020}	70 _{-0.20}	70	M110x2
220	CGAK120	R900321621	R900323333	1700	612.0	125	155	266	265	110 _{-0.020}	70 _{-0.20}	80	M120x3
250	CGAK120	R900321621	R900323333	1700	612.0	125	153	265	265	110 _{-0.020}	70 _{-0.20}	80	M120x3
280	CGAK130	R900322015	R900540850	2900	1044.0	135	173	340	310	120 _{-0.020}	85 _{-0.20}	90	M130x3

Swivel head CGAK (clampable)
 (dimensions in mm)

ØAL	Type	L1	L2 max	LF	Z	Clamping screws ISO 4762-10.9	M _A ³⁾ Nm	m ⁴⁾ kg
40	CGAK 16	80	24	28	7 °	M8	30	0.43
50	CGAK 22	94	26	30	6 °	M8	30	0.7
63	CGAK 28	112	34	38	6 °	M10	54	1.1
80	CGAK 35	135	39	45	7 °	M10	59	2.0
100	CGAK 45	168	46	55	6 °	M12	100	3.3
125	CGAK 58	200	61	65	6 °	M16	250	5.5
140	CGAK 65	232	66	75	6 °	M16	250	8.6
160	CGAK 80	265	81	80	6 °	M20	490	12.2
180	CGAK100	323	91	90	5 °	M20	490	21.5
200	CGAK110	360	101	105	7 °	M24	840	27.5
220	CGAK120	407.5	111	115	6 °	M24	840	40.7
250	CGAK120	407.5	111	115	6 °	M24	840	40.7
280	CGAK130	490	129	140	6 °	M24	840	76.4

The specified dimensions are maximum values and may differ depending on the manufacturer.
 The following values are excluded: CH, CN, EN, EU, KK

The swivel head must always be screwed against the shoulder of the piston rod and secured against loosening!

ØAL = piston Ø

- 1) Grease nipple, cone head form A according to DIN 71412;
 not applicable to spherical bearing, maintenance-free "A"
- 2) Related bolt Ø m6;
 Related bolt Ø j6 with maintenance-free spherical bearing
- 3) **M_A** = tightening torque
- 4) **m** = weight of swivel head in kg
- 5) **C₀** = static load rating of the swivel head
- 6) **F_{adm}** = max. admissible load of the swivel head with oscillatory
 or alternating loads

Swivel head CGAS (clampable)

(dimensions in mm)

ØAL 40-320 mm

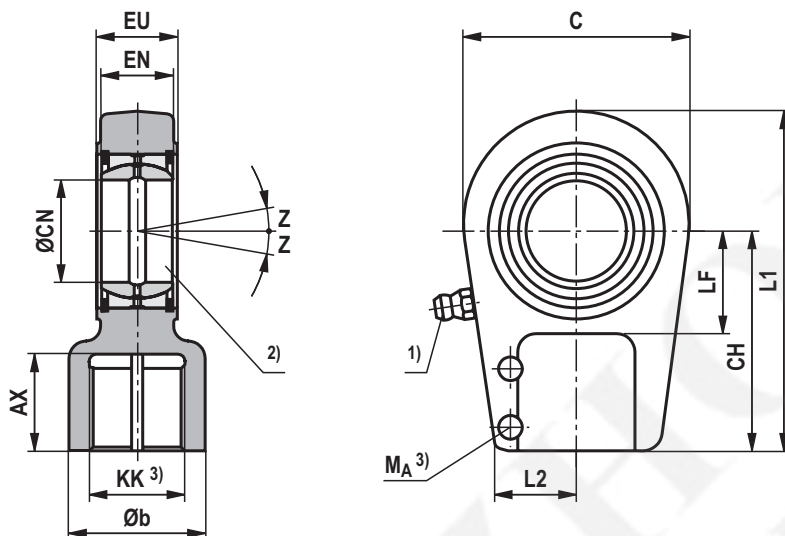

ØAL	Type	Material no. requiring maintenance	Material no. maintenance-free	C ₀ ⁶⁾ kN	F _{adm} ⁷⁾ kN	AX min	Øb max	C max	CH	ØCN ²⁾	EN	EU -0.4	KK
40	CGAS 25	R900303137	R900321681	82	27.1	30	28	56	65	25 _{-0.010}	20 _{-0.12}	23	M18x2
50	CGAS 30	R900303138	R900321696	122	40.3	35	34	64	75	30 _{-0.010}	22 _{-0.12}	28	M24x2
63	CGAS 35	R900303139	R900322716	177	58.4	46	46	78	90	35 _{-0.012}	25 _{-0.12}	30	M30x2
80	CGAS 40	R900303140	R900321665	287	94.7	56	57	94	105	40 _{-0.012}	28 _{-0.12}	35	M39x3
100	CGAS 50	R900303141	R900322017	422	139.3	76	70	116	135	50 _{-0.012}	35 _{-0.12}	40	M50x3
125	CGAS 60	R900303142	R900321685	522	172.3	96	87	130	170	60 _{-0.015}	44 _{-0.15}	50	M64x3
140	CGAS 70	R900303143	R900321690	707	233.3	112	111	154	195	70 _{-0.015}	49 _{-0.15}	55	M80x3
160	CGAS 80	R900303144	R900322022	870	287.1	122	129	176	210	80 _{-0.015}	55 _{-0.15}	60	M90x3
180	CGAS 90	R900303145	R900323344	1284	423.7	142	153	211	250	90 _{-0.020}	60 _{-0.20}	65	M100x3
200	CGAS100	R900303146	R900321689	1460	481.8	152	170	230	275	100 _{-0.020}	70 _{-0.20}	70	M110x4
220	CGAS110	R900303147	R900323326	2024	667.9	162	180	264	300	110 _{-0.020}	70 _{-0.20}	80	M120x4
250	CGAS110	R900303147	R900323326	2024	667.9	162	180	264	300	110 _{-0.020}	70 _{-0.20}	80	M120x4
280	CGAS120	R900303148	R900324830	2970	980.1	192	210	340	360	120 _{-0.020}	85 _{-0.20}	90	M150x4
320	CGAS140	R900317314	R900540515	3350	1105.5	210	230	380	420	140 _{-0.025}	90 _{-0.25}	110	M160x4

Swivel head CGAS (clampable)

(dimensions in mm)

ØAL	Type	L1 max	L2 max	LF min	Z ³⁾	Clamping screws ISO 4762-10.9	M _A ⁴⁾ Nm	m ⁵⁾ kg
40	CGAS 25	95	24	25	7-8 °	M8	30	0.65
50	CGAS 30	109	28	30	6-7 °	M8	30	1.0
63	CGAS 35	132	36	40	6-7 °	M10	59	1.5
80	CGAS 40	155	39	44	7 °	M12	100	2.4
100	CGAS 50	198	45	55	6-7 °	M12	100	4.8
125	CGAS 60	240	59	65	6-7 °	M16	250	8.6
140	CGAS 70	279	70	75	6 °	M16	250	12.2
160	CGAS 80	305	85	80	6 °	M20	490	18.4
180	CGAS 90	366	91	90	5 °	M20	490	31.6
200	CGAS100	400	95	105	7 °	M20	490	34
220	CGAS110	443	106	115	6 °	M24	840	44
250	CGAS110	443	106	115	6 °	M24	840	44
280	CGAS120	540	122	140	6 °	M24	840	75
320	CGAS140	620	129	185	7 °	M30	1700	160

The specified dimensions are maximum values and may differ depending on the manufacturer.

The following values are excluded: CH, CN, EN, EU, KK

The swivel head must always be screwed against the shoulder of the piston rod and secured against loosening!

ØAL = piston Ø

- 1) Grease nipple, cone head form A according to DIN 71412;
not applicable to spherical bearing, maintenance-free "A"
- 2) Related bolt Ø m6;
Related bolt Ø j6 for maintenance-free
Spherical bearing
- 3) Dimensions may differ depending on the manufacturer
- 4) **M_A** = tightening torque
- 5) **m** = weight of swivel head in kg
- 6) **C₀** = static load rating of the swivel head
- 7) **F_{adm}** = max. admissible load of the swivel head with oscillatory
or alternating loads

Buckling

For the admissible stroke length with flexibly guided load and a factor of 3.5 for safety against buckling, please refer to the relevant table. For other installation positions of the cylinder, the admissible stroke length must be interpolated. Admissible stroke length for non-guided load on request. Buckling calculations are carried out according to the following formulas:

1. Calculation according to Euler

$$F = \frac{\pi^2 \cdot E \cdot I}{\nu \cdot L_K^2} \quad \text{if } \lambda > \lambda_g$$

2. Calculation according to Tetmajer

$$F = \frac{d^2 \cdot \pi (335 - 0.62 \cdot \lambda)}{4 \cdot \nu} \quad \text{if } \lambda \leq \lambda_g$$

Influence of the type of mounting on the bending length:

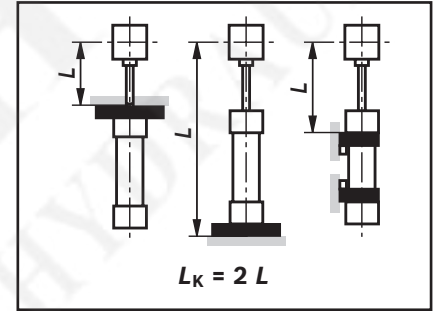
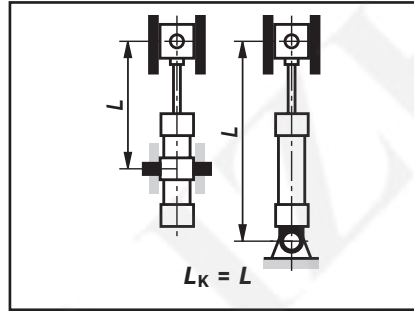
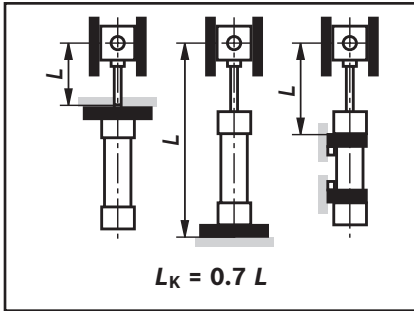

Explanation:

- E** = module of elasticity in N/mm²
= 2.1 x 10⁵ for steel
- I** = geometrical moment of inertia in mm⁴ for circular cross-section
 $= \frac{d^4 \cdot \pi}{64} = 0.0491 \cdot d^4$
- ν** = 3.5 (safety factor)
- L_K** = free bending length in mm (depending on the type of mounting see sketches A, B, C)
- d** = Piston rod Ø in mm
- λ** = Slenderness ratio
 $= \frac{4 \cdot L_K}{d} \quad \lambda_g = \pi \sqrt{\frac{E}{0.8 \cdot R_e}}$
- R_e** = yield strength of the piston rod material

Admissible stroke length (dimensions in mm)

Type of mounting CDH1/CSH1²⁾: MP3, MP5

ØAL	ØMM	Admissible stroke length with									Installation position
		100 bar			160 bar			250 bar			
		0 °	45 °	90 °	0 °	45 °	90 °	0 °	45 °	90 °	
40	22	195	200	215	130	135	140	40	45	55	
	28	385	400	445	295	300	320	215	220	225	
50	28	285	295	310	205	210	215	120	130	135	
	36	535	555	625	425	430	460	320	325	335	
63	36	390	400	440	290	295	305	200	205	210	
	45	655	685	790	530	545	585	410	415	430	
80	45	500	515	560	375	385	400	240	260	280	
	56	815	850	980	665	680	735	520	525	545	
100	56	610	630	705	470	480	505	280	295	355	
	70	985	1030	1240	820	845	930	650	660	695	
125	70	770	800	900	600	615	650	360	380	465	
	90	1295	1360	1670	1095	1130	1265	885	900	955	
140	90	1145	1200	1430	945	970	1070	740	755	790	
	100	1400	1475	1840	1190	1230	1390	965	985	1050	
160	100	1230	1285	1530	1010	1040	1140	790	800	840	
	110	1480	1555	1930	1250	1290	1455	1005	1030	1090	
180	110	1305	1365	1630	1065	1095	1200	825	840	880	
	125	1675	1765	2210	1420	1470	1670	1150	1175	1260	
200	125	1500	1580	1930	1240	1290	1430	985	1005	1060	
	140	1865	1965	2520	1590	1660	1910	1305	1340	1440	
220	140	1620	1710	2180	1360	1415	1630	1090	1120	1200	
	160	2075	2200	3000	1810	1890	2280	1510	1560	1730	
250	160	1885	1990	2570	1600	1670	1930	1300	1330	1440	
	180	2330	2475	3370	2040	2135	2570	1710	1770	1960	
280	180	2075	2200	2900	1775	1880	2170	1450	1490	1620	
	200	2510	2670	3700	2200	2310	2820	1850	1920	2140	
320	200	2170	2300	3070	1850	1940	2290	1500	1550	1700	
	220	2590	2760	3850	2260	2380	2920	1890	1960	2200	

1) Adm. Stroke length

Admissible stroke length
 (dimensions in mm)

Type of mounting CDH1/CGH1/CSH1 ²⁾: MF3

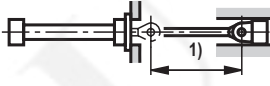
ØAL	ØMM	Admissible stroke length with									Installation position
		100 bar			160 bar			250 bar			
		0 °	45 °	90 °	0 °	45 °	90 °	0 °	45 °	90 °	
40	22	895	915	980	730	735	760	440	450	510	 0 °
	28	1400	1415	1630	1180	1205	1275	970	980	1010	
50	28	1180	1200	1280	955	965	995	700	730	780	
	36	1785	1855	2160	1530	1570	1695	1275	1290	1340	
63	36	1520	1560	1690	1250	1270	1315	1010	1015	1035	
	45	2000	2000	2000	1875	1925	2000	1570	1595	1670	
80	45	1855	1905	2000	1540	1560	1630	1140	1180	1280	
	56	2000	2000	2000	2000	2000	2000	1910	1940	2000	
100	56	2250	2320	2500	1880	1910	2010	1300	1360	1580	
	70	3000	3000	3000	2770	2860	3000	2360	2400	2550	
125	70	2760	2860	3000	2330	2375	2520	1580	1680	1990	
	90	3000	3000	3000	3000	3000	3000	3000	3000	3000	
140	90	3000	3000	3000	3000	3000	3000	2770	2820	2980	
	100	3000	3000	3000	3000	3000	3000	3000	3000	3000	
160	100	3000	3000	3000	3000	3000	3000	2980	3000	3000	
	110	3000	3000	3000	3000	3000	3000	3000	3000	3000	
180	110	3000	3000	3000	3000	3000	3000	3000	3000	3000	
	125	3000	3000	3000	3000	3000	3000	3000	3000	3000	
200	125	3000	3000	3000	3000	3000	3000	3000	3000	3000	
	140	3000	3000	3000	3000	3000	3000	3000	3000	3000	
220	140	5400	5680	6000	4800	4980	5780	4120	4220	4560	
	160	6000	6000	6000	5820	6000	6000	5150	5330	6000	
250	160	6000	6000	6000	5450	5660	6000	4720	4840	5290	
	180	6000	6000	6000	6000	6000	6000	5730	5920	6000	
280	180	6000	6000	6000	6000	6000	6000	5270	5420	5970	
	200	6000	6000	6000	6000	6000	6000	6000	6000	6000	
320	200	6000	6000	6000	6000	6000	6000	6000	6000	6000	
	220	6000	6000	6000	6000	6000	6000	6000	6000	6000	

1) Adm. Stroke length

Type of mounting CDH1/CSH1 ²⁾: MF4

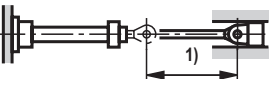
ØAL	ØMM	Admissible stroke length with									Installation position
		100 bar			160 bar			250 bar			
		0 °	45 °	90 °	0 °	45 °	90 °	0 °	45 °	90 °	
40	22	325	340	370	245	250	260	105	110	140	 0 °
	28	565	590	695	465	475	520	365	370	385	
50	28	455	470	515	350	360	375	220	230	265	
	36	770	805	960	640	660	725	515	525	550	
63	36	600	620	710	475	490	520	350	370	380	
	45	930	975	1210	790	820	920	645	660	700	
80	45	760	785	895	610	625	670	395	420	495	
	56	1150	1210	1495	985	1020	1145	810	825	875	
100	56	905	945	1120	745	765	835	420	460	620	
	70	1370	1445	1880	1190	1235	1440	995	1020	1100	
125	70	1175	1225	1460	980	1010	1105	580	620	835	
	90	1815	1920	2560	1600	1670	1980	1365	1400	1540	
140	90	1600	1695	2190	1390	1440	1670	1150	1180	1275	
	100	1915	2030	2770	1695	1770	2130	1440	1490	1650	
160	100	1730	1825	2350	1490	1550	1790	1235	1265	1365	
	110	2030	2155	2910	1790	1870	2240	1520	1565	1720	
180	110	1850	1950	2510	1590	1655	1900	1310	1340	1450	
	125	2295	2440	3000	2030	2130	2570	1730	1785	1980	
200	125	2110	2230	2270	1835	1910	2250	1530	1575	1720	
	140	2540	2700	3000	2265	2380	2930	1945	2010	2260	
220	140	2250	2400	3350	1990	2090	2550	1685	1740	1950	
	160	2800	2990	4500	2530	2680	3480	2220	2310	2700	
250	160	2615	2780	3900	2320	2435	3000	1980	2050	2300	
	180	3140	3360	5050	2850	3010	3910	2500	2610	3050	
280	180	2850	3050	4400	2550	2680	3370	2190	2270	2600	
	200	3370	3610	5550	3070	3250	4300	2700	2820	3330	
320	200	3000	3210	4700	2680	2830	3590	2100	2390	2750	
	220	3500	3750	5800	3180	3370	4480	2790	2920	3460	

1) Adm. Stroke length

Admissible stroke length

(dimensions in mm)

Type of mounting CDH1/CGH1/CSH1 ²⁾: MT4 trunnion in cylinder center

ØAL	ØMM	Admissible stroke length with									Installation position
		100 bar			160 bar			250 bar			
		0 °	45 °	90 °	0 °	45 °	90 °	0 °	45 °	90 °	
40	22	340	345	365	250	255	260	130	135	145	
	28	590	605	665	470	480	500	365	370	375	
50	28	460	470	495	350	355	365	245	250	260	
	36	790	815	910	645	655	690	510	515	525	
63	36	610	625	675	475	485	500	360	365	370	
	45	965	1000	1140	800	815	870	635	645	665	
80	45	770	790	850	605	615	635	440	455	475	
	56	1190	1235	1410	990	1010	1080	795	805	830	
100	56	930	955	1060	745	755	795	490	510	595	
	70	1430	1490	1770	1210	1240	1360	985	1000	1045	
125	70	1185	1225	1360	960	980	1030	640	670	780	
	90	1885	1970	2390	1620	1665	1850	1340	1360	1430	
140	90	1675	1710	2060	1410	1415	1575	1140	1155	1205	
	100	2020	2115	2610	1735	1790	2010	1440	1465	1555	
160	100	1805	1880	2210	1510	1550	1680	1215	1230	1285	
	110	2140	2240	2740	1830	1885	2100	1505	1535	1620	
180	110	1925	2005	2360	1605	1650	1790	1290	1310	1360	
	125	2420	2540	3000	2080	2150	2420	1720	1755	1865	
200	125	2130	2230	2690	1790	1840	2040	1440	1465	1540	
	140	2610	2750	3000	2250	2330	2670	1865	1910	2050	
220	140	2490	2510	3150	2050	2120	2400	1685	1720	1835	
	160	3000	3170	4230	2640	2750	3260	2240	2310	2530	
250	160	2750	2900	3660	2380	2460	2810	1970	2020	2160	
	180	3350	3540	4750	2960	3090	3670	2520	2600	2850	
280	180	3040	3210	4140	2640	2750	3170	2210	2260	2440	
	200	3620	3840	5210	3210	3360	4040	2750	2830	3140	
320	200	3210	3390	4410	2790	2900	3380	2320	2380	2580	
	220	3770	4000	5450	3340	3490	4200	2850	2930	3250	

1) Adm. Stroke length

Type of mounting CDH1/CGH1/CSH1 ²⁾: MS2

ØAL	ØMM	Admissible stroke length with									Installation position
		100 bar			160 bar			250 bar			
		0 °	45 °	90 °	0 °	45 °	90 °	0 °	45 °	90 °	
40	22	825	840	885	645	650	665	370	375	410	
	28	1305	1350	1535	1085	1110	1180	875	885	910	
50	28	1075	1100	1175	855	865	890	610	625	675	
	36	1680	1750	2000	1430	1465	1590	1175	1190	1240	
63	36	1405	1440	1570	1135	1155	1200	895	900	920	
	45	2000	2000	2000	1760	1810	1990	1460	1480	1555	
80	45	1730	1780	1960	1410	1435	1500	1000	1050	1155	
	56	2000	2000	2000	2000	2000	2000	1785	1820	1920	
100	56	2110	2180	2440	1740	1770	1870	1140	1220	1440	
	70	3000	3000	3000	2620	2710	3000	2210	2260	2400	
125	70	2600	2695	3000	2170	2210	2360	1400	1480	1820	
	90	3000	3000	3000	3000	3000	3000	2890	2970	3000	
140	90	3000	3000	3000	3000	3000	3000	2585	2635	2800	
	100	3000	3000	3000	3000	3000	3000	3000	3000	3000	
160	100	3000	3000	3000	3000	3000	3000	2760	2810	2990	
	110	3000	3000	3000	3000	3000	3000	3000	3000	3000	
180	110	3000	3000	3000	3000	3000	3000	2940	3000	3000	
	125	3000	3000	3000	3000	3000	3000	3000	3000	3000	
200	125	3000	3000	3000	3000	3000	3000	3000	3000	3000	
	140	3000	3000	3000	3000	3000	3000	3000	3000	3000	
220	140	5090	5370	6000	4490	4670	5470	3820	3910	4260	
	160	6000	6000	6000	5510	5800	6000	4850	5020	5750	
250	160	5790	6000	6000	5150	5370	6000	4420	4540	4990	
	180	6000	6000	6000	6000	6000	6000	5420	5630	6000	
280	180	6000	6000	6000	5700	5960	6000	4930	5070	5630	
	200	6000	6000	6000	6000	6000	6000	6000	6000	6000	
320	200	6000	6000	6000	6000	6000	6000	5200	5400	6000	
	220	6000	6000	6000	6000	6000	6000	6000	6000	6000	

1) Adm. Stroke length

With longer strokes, an extended guide and/or the use of guide rings may be reasonable for increasing the service life, depending on the respective case of application and installation position. Recommendation on request.

²⁾ With CSH1, observe the maximum stroke length "X*max", pages 30 to 41

End position cushioning

End position cushioning:

The objective is to reduce the velocity of a moved mass, the center of gravity of which lies on the cylinder axis, to a level at which neither the cylinder nor the machine into which the cylinder is installed is damaged. For velocities above 20 mm/s, we recommend the use of an end position cushioning feature, which absorbs energy without requiring the use of additional equipment. It must, however, always be checked whether end position cushioning is also required for lower velocities with large masses.

Damping capacity:

When decelerating masses via end position cushioning, the structural-inherent damping capacity must not be exceeded. Cylinders with end position cushioning can achieve their full damping capacity only over the entire stroke length.

With the adjustable end position cushioning version "E", a throttle valve is additionally provided when compared with version "D". End position cushioning version "E" allows cycle times to be optimized. The max. damping

capacity can only be achieved when the throttle valve is closed.

The calculation depends on the factors mass, velocity, system pressure and installation position. For this reason, mass and velocity are used to determine the characteristic D_m and system pressure and installation position to determine the characteristic D_p .

These two characteristics are used for verifying the admissible damping capacity in the "damping capacity" diagram. The intersection point of the characteristics D_m and D_p must always be below the damping capacity curve of the selected cylinder. The values in the diagrams refer to an average oil temperature of +45 to +65 °C with the throttle valve being closed.

For special applications with very short stroke times, high velocities or large masses, cylinders with special end position cushioning versions can be offered on request. When fixed or adjustable stops are used, special measures must be taken!

Formulas:

$$D_m = \frac{m}{10K}; K = kv(0.5-v)$$

- m = moved mass in kg
- v = stroke velocity in m/s
- kv = see table page 69

Extension for CDH1 and CSH1

$$D_p = p_s - \frac{m \cdot 9.81 \cdot \sin \alpha}{A_1 \cdot 10}$$

Retraction for CDH1, CGH1 and CSH1; extension for CGH1

$$D_p = p_s + \frac{m \cdot 9.81 \cdot \sin \alpha}{A_3 \cdot 10}$$

- p_s = system pressure in bar
- A_1 = piston area in cm² (see page 14)
- A_3 = annulus area in cm² (see page 14)
- α = angle to the horizontal in degree

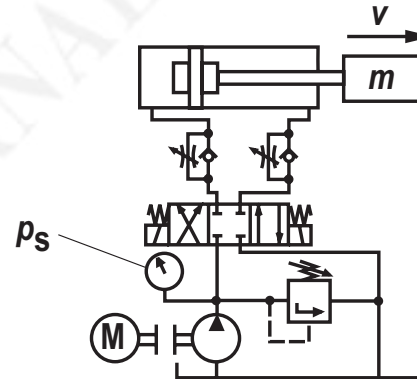
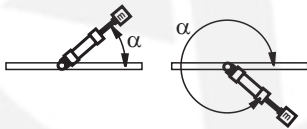

Damping length

With cylinder strokes within the damping lengths, restrictions with regard to velocity / cycle time are possible. We recommend minimum stroke greater than the damping length plus 10 mm!

ØAL mm	40	50	63	80	100	125	140	160	180	200	220	250	280	320
Head side	21	20	23	25	25	25	33	33	37	37	76	81	86	90
Base side	21	20	23	25	25	25	33	33	37	37	76	81	86	90

End position cushioning

ØAL mm	40	50	63	80	100	125	140	160	180	200	220	250	280	320
kv ①	2.85	2.97	2.56	2.82	3.51	3.02	2.53	2.65	2.91	2.76	2.85	2.95	3.11	3.13
kv ②	3.1	3.25	2.85	2.85	3.52	2.91	2.53	2.93	2.95	2.95	2.93	3.1	3.12	3.07
kv ③	2.95	3.1	2.73	3.1	3.51	2.95	2.51	2.91	2.95	2.91	2.93	2.93	3.15	3.25

Damping capacity: Extension for CDH1 and CSH1, with kv ①

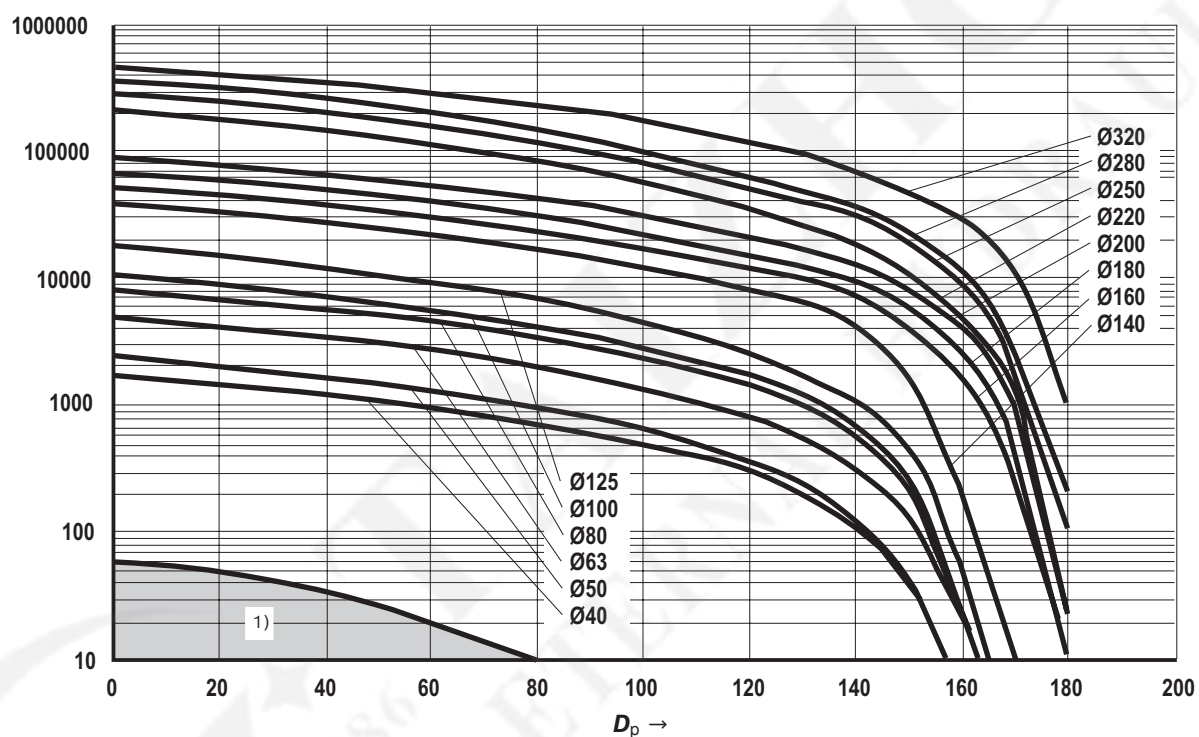

ØAL = piston Ø

1) If with standard applications the calculated intersection point of D_m and D_p is within the marked area, we recommend designing the cylinder without end position cushioning.

End position cushioning

Damping capacity: Retraction for CDH1, CGH1 and CSH1; extension for CGH1 with k_v ②

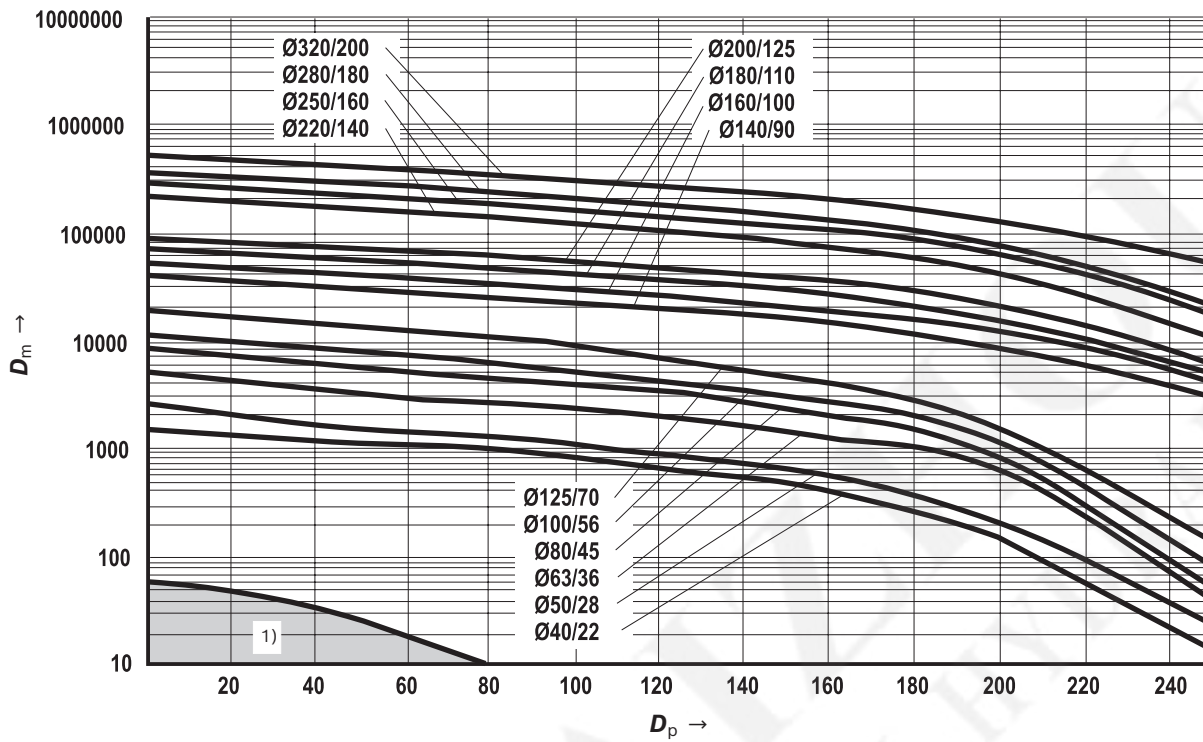

Damping capacity: Retraction for CDH1, CGH1 and CSH1; extension for CGH1 with k_v ③

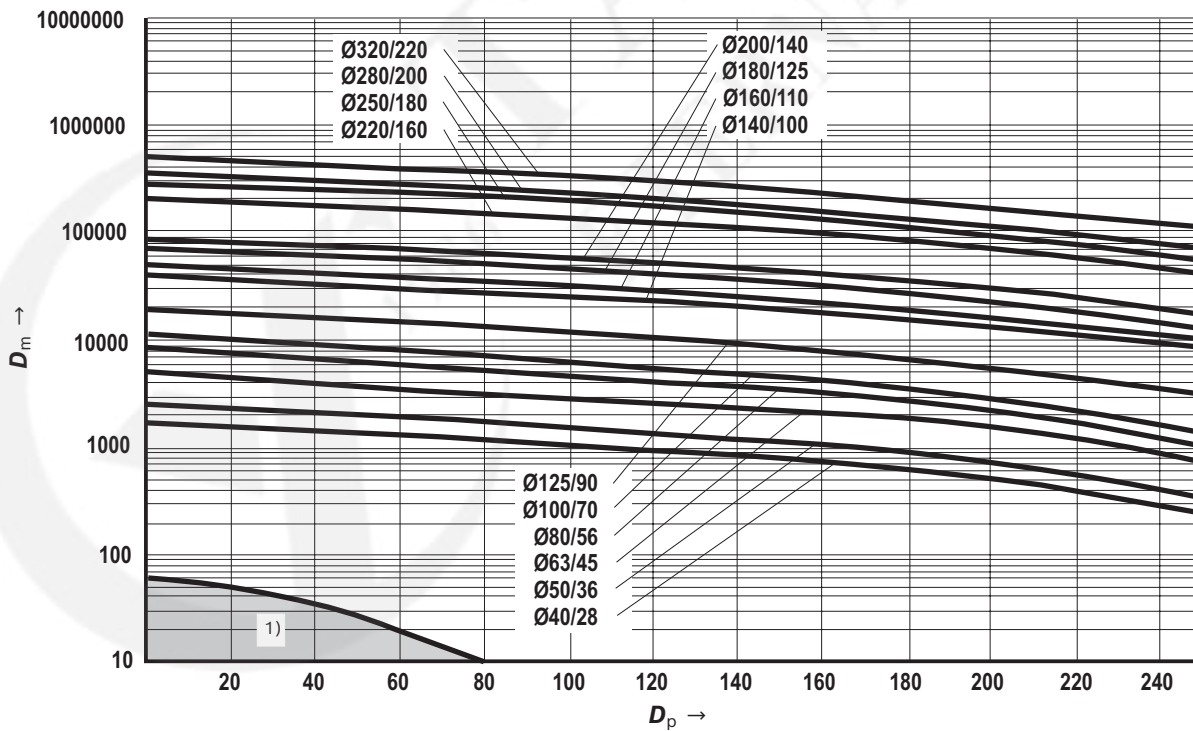

1) If with standard applications the calculated intersection point of D_m and D_p is within the marked area, we recommend designing the cylinder without end position cushioning.

Selection criteria for seals

The specified values are to be regarded as guidelines; depending on the application, it may be necessary to check the suitability of the seal system. Generally, a medium temperature of approx. 40 °C is recommended.

Work and environmental conditions		Seal versions								
		M	G	V	L	A	B	T	R	S
Medium / temperature	Medium HL, HLP / operating temperature medium	++	++	++	++	++	++	++	++	++
	Medium HFA / operating temperature medium +5 °C ... +55 °C	+/-	+/-	+/-	+/-	+	+/-	++	+/-	+/-
	Medium HFC / operating temperature medium -20 °C ... +60 °C	-	++	-	-	+/-	-	++	-	-
	Medium HFDR / operating temperature medium -15 °C ... +80 °C	-	-	++	-	-	++	-	-	++
	Medium HFDU / operating temperature medium -15 °C ... +80 °C	-	-	++	-	-	++	-	-	++
	Ambient and rod temperature in the area of the piston rod from -20 °C ... +80 °C ¹⁾	++	+	+ 2)	++	++	+ 2)	+	++	++ 2)
	Extended ambient and rod temperature in the area of the piston rod from +80 °C ... +120 °C ¹⁾	-	-	++	-	-	+	-	-	++
Function / velocity...	static hold function more than 10 minutes: Attention! Application- and temperature-dependent	++	+	+	+	++	++	+	+	+
	Static hold function short-time < 1 minute	++	++	++	++	++	++	++	++	++
	Robust application conditions: Steel works, mining, thin ice	++	++	++	++	++	++	-	++	-
	Zero point control, hardly any amplitude, frequency max. 5 Hz, not longer than 5 minutes	-	-	-	+/-	-	-	++	+	++
	Cylinder velocity min. 0.001 m/sec stick-slip behavior	++	+	+	++	-	-	++	++	++
	Cylinder velocity from 0.01 m/sec to 0.5 m/sec ³⁾	++	+	+	++	+	+	++	++	++
	Cylinder velocity > 0.5 m/sec to max. 0.8 m/sec ³⁾	-	+/-	+/-	++	-	-	++	+	++
	Stroke > 1.0 m	+/-	++	++	++	++	++	++	++	++
	Standstill period (wear)	++	+/-	+/-	++	+/-	-	++	++	++
Undissolved air in the oil ⁴⁾	-	+	+	+	-	-	+	+	+	

++ = very good + = good +/- = conditional, depending on the application parameters - = inappropriate

General technical data in corresponding data sheets will remain valid, see page 11!

- 1) Moreover, observe the corresponding medium temperature range
- 2) Lower temperature limit -15 °C
- 3) Standard line connections not designed for that velocity
- 4) - Seal is destroyed / + Seal is not directly destroyed, leakage may occur

Seal kits 1)

CDH1 – Standard

ØAL	ØMM	Material no. for seal design								
		M	G	V	L	A	B	T	R	S
40	22	R900850072	R961006000	R961006035	R961006070	R900860270	–	R900849536	R961006105	R900861000
	28	R900851087	R961006002	R961006037	R961006072	R900859445	R900859770	R900858841	R961006107	R900861001
50	28	R900850181	R961006003	R961006038	R961006073	R900860928	R900860938	R900857535	R961006108	R900861002
	36	R900849392	R961006005	R961006040	R961006075	R900851515	R900860940	R900860277	R961006110	R900861004
63	36	R900850191	R961006006	R961006041	R961006076	R900860930	R900851206	R900860278	R961006111	R900861005
	45	R900847956	R961006008	R961006043	R961006078	R900851638	R900859678	R900847855	R961006113	R900861007
80	45	R900851086	R961006009	R961006044	R961006079	R900854708	R900860942	R900860280	R961006114	R900861008
	56	R900850905	R961006011	R961006046	R961006081	R900854718	R900851205	R900856180	R961006116	R900861010
100	56	R900853936	R961006012	R961006047	R961006082	R900860470	R900860944	R900860282	R961006117	R900861011
	70	R900853382	R961006014	R961006049	R961006084	R900856094	R900860946	R900860285	R961006119	R900861013
125	70	R900853966	R961006015	R961006050	R961006085	R900854709	R900860948	R900860286	R961006120	R900861014
	90	R900857949	R961006017	R961006052	R961006087	R900856095	R900855464	R900856102	R961006122	R900861016
140	90	R900858281	R961006018	R961006053	R961006088	R900860932	R900860951	R900860289	R961006123	R900861017
	100	R900853965	R961006019	R961006054	R961006089	R900856096	R900860952	R900860290	R961006124	R900849080
160	100	R900855683	R961006020	R961006055	R961006090	R900860468	R900860953	R900860291	R961006125	R900861018
	110	R900851146	R961006021	R961006056	R961006091	R900860933	R900860954	R900857536	R961006126	R900861019
180	110	R900856497	R961006023	R961006058	R961006093	R900860934	R900860955	R900852561	R961006128	R900861020
	125	R900848603	R961006024	R961006059	R961006094	R900860935	R900860956	R900860292	R961006129	R900861021
200	125	R900860294	R961006025	R961006060	R961006095	R900860936	R900860957	R900860295	R961006130	R900861022
	140	R900856431	R961006026	R961006061	R961006096	R900860937	R900860958	R900860293	R961006131	R900861023
220	140	R900888100	R961006027	R961006062	R961006097	R900888116	R900888140	R900888108	R961006132	R900888132
	160	R900888101	R961006028	R961006063	R961006098	R900888117	R900888141	R900888109	R961006133	R900888133
250	160	R900888102	R961006029	R961006064	R961006099	R900888118	R900888142	R900888110	R961006134	R900888134
	180	R900888103	R961006030	R961006065	R961006100	R900888119	R900888143	R900888111	R961006135	R900888135
280	180	R900888104	R961006031	R961006066	R961006101	R900888120	R900888144	R900888112	R961006136	R900888136
	200	R900888105	R961006032	R961006067	R961006102	R900888121	R900888145	R900888113	R961006137	R900888137
320	200	R900888106	R961006033	R961006068	R961006103	R900888122	R900888146	R900888114	R961006138	R900888138
	220	R900888107	–	–	R961006104	R900888123	R900888147	R900888115	R961006139	R900888139

ØAL = piston Ø

ØMM = piston rod Ø

1) Seal kits for proximity switches and subplate mounting separate material no.

Seal kits 1)

CGH1 – Standard

ØAL	ØMM	Material no. for seal design								
		M	G	V	L	A	B	T	R	S
40	22	R900867251	R961006221	R961006256	R961006291	R900866746	-	R900868888	R961006326	R900868942
	28	R900867252	R961006223	R961006258	R961006293	R900866747	R900867133	R900868889	R961006328	R900868943
50	28	R900867253	R961006224	R961006259	R961006294	R900866748	R900867134	R900868890	R961006329	R900868944
	36	R900864930	R961006226	R961006261	R961006296	R900866750	R900867136	R900868892	R961006331	R900868946
63	36	R900867260	R961006227	R961006262	R961006297	R900866751	R900867137	R900868893	R961006332	R900868947
	45	R900867262	R961006229	R961006264	R961006299	R900866753	R900867139	R900868895	R961006334	R900868949
80	45	R900867263	R961006230	R961006265	R961006300	R900866754	R900867140	R900868896	R961006335	R900868950
	56	R900867265	R961006232	R961006267	R961006302	R900866756	R900867142	R900868898	R961006337	R900868952
100	56	R900867266	R961006233	R961006268	R961006303	R900866757	R900867143	R900868899	R961006338	R900868953
	70	R900867268	R961006235	R961006270	R961006305	R900866759	R900867146	R900868901	R961006340	R900868955
125	70	R900867269	R961006236	R961006271	R961006306	R900866760	R900867147	R900868902	R961006341	R900867906
	90	R900867270	R961006238	R961006273	R961006308	R900866762	R900867149	R900868904	R961006343	R900868957
140	90	R900867271	R961006239	R961006274	R961006309	R900866763	R900867150	R900868905	R961006344	R900868958
	100	R900867272	R961006240	R961006275	R961006310	R900866764	R900867151	R900868906	R961006345	R900868959
160	100	R900867273	R961006241	R961006276	R961006311	R900866765	R900867152	R900868907	R961006346	R900868960
	110	R900867274	R961006242	R961006277	R961006312	R900866766	R900867153	R900868908	R961006347	R900868961
180	110	R900867275	R961006244	R961006279	R961006314	R900866767	R900867154	R900868909	R961006349	R900868962
	125	R900867276	R961006245	R961006280	R961006315	R900866768	R900867155	R900868910	R961006350	R900868963
200	125	R900867277	R961006246	R961006281	R961006316	R900866769	R900867156	R900868911	R961006351	R900868964
	140	R900867278	R961006247	R961006282	R961006317	R900866770	R900867157	R900868912	R961006352	R900868965
220	140	R900888020	R961006248	R961006283	R961006318	R900888036	R900888060	R900888028	R961006353	R900888052
	160	R900888021	R961006249	R961006284	R961006319	R900888037	R900888061	R900888029	R961006354	R900888053
250	160	R900888022	R961006250	R961006285	R961006320	R900888038	R900888062	R900888030	R961006355	R900888054
	180	R900888023	R961006251	R961006286	R961006321	R900888039	R900888063	R900888031	R961006356	R900888055
280	180	R900888024	R961006252	R961006287	R961006322	R900888040	R900888064	R900888032	R961006357	R900888056
	200	R900888025	R961006253	R961006288	R961006323	R900888041	R900888065	R900888033	R961006358	R900888057
320	200	R900888026	R961006254	R961006289	R961006324	R900888042	R900888066	R900888034	R961006359	R900888058
	220	R900888027	-	-	R961006325	R900888043	R900888067	R900888035	R961006360	R900888059

ØAL = piston Ø
 ØMM = piston rod Ø

1) Seal kits for proximity switches and subplate mounting separate material no.

Seal kits 1)

CDH1 – Standard + additional option F

ØAL	ØMM	Material no. for seal design					
		M+F	G+F	V+F	T+F	R+F	S+F
40	22	R900861024	R961006140	R961006167	R900861049	R961006194	R900861099
	28	R900861025	R961006142	R961006169	R900861050	R961006196	R900861100
50	28	R900861026	R961006143	R961006170	R900861051	R961006197	R900861101
	36	R900861028	R961006145	R961006172	R900861053	R961006199	R900861103
63	36	R900861029	R961006146	R961006173	R900861054	R961006200	R900861104
	45	R900861031	R961006148	R961006175	R900861056	R961006202	R900861106
80	45	R900861032	R961006149	R961006176	R900861057	R961006203	R900861107
	56	R900861034	R961006151	R961006178	R900861059	R961006205	R900861109
100	56	R900861035	R961006152	R961006179	R900861060	R961006206	R900861112
	70	R900861037	R961006154	R961006181	R900861062	R961006208	R900861115
125	70	R900861038	R961006155	R961006182	R900861063	R961006209	R900861117
	90	R900861040	R961006157	R961006184	R900861065	R961006211	R900861122
140	90	R900861041	R961006158	R961006185	R900861066	R961006212	R900861124
	100	R900861042	R961006159	R961006186	R900861067	R961006213	R900861126
160	100	R900861043	R961006160	R961006187	R900861068	R961006214	R900861128
	110	R900861044	R961006161	R961006188	R900861069	R961006215	R900861130
180	110	R900861045	R961006163	R961006190	R900861070	R961006217	R900861133
	125	R900861046	R961006164	R961006191	R900861071	R961006218	R900861135
200	125	R900861047	R961006165	R961006192	R900861072	R961006219	R900861142
	140	R900861048	R961006166	R961006193	R900861073	R961006220	R900861143

CGH1 – Standard + additional option F

ØAL	ØMM	Material no. for seal design					
		M+F	G+F	V+F	T+F	R+F	S+F
40	22	R900868998	R961006361	R961006388	R900869025	R961006415	R900869092
	28	R900868999	R961006363	R961006390	R900869026	R961006417	R900869093
50	28	R900869000	R961006364	R961006391	R900869027	R961006418	R900869094
	36	R900869002	R961006366	R961006393	R900869029	R961006420	R900869096
63	36	R900869003	R961006367	R961006394	R900869030	R961006421	R900869097
	45	R900869005	R961006369	R961006396	R900869032	R961006423	R900869099
80	45	R900869006	R961006370	R961006397	R900869033	R961006424	R900869100
	56	R900869008	R961006372	R961006399	R900869035	R961006426	R900869102
100	56	R900869009	R961006373	R961006400	R900869036	R961006427	R900869103
	70	R900869013	R961006375	R961006402	R900869038	R961006429	R900869105
125	70	R900869014	R961006376	R961006403	R900869039	R961006430	R900869106
	90	R900869016	R961006378	R961006405	R900869041	R961006432	R900869108
140	90	R900869017	R961006379	R961006406	R900869042	R961006433	R900869109
	100	R900869018	R961006380	R961006407	R900869043	R961006434	R900869110
160	100	R900869019	R961006381	R961006408	R900869044	R961006435	R900869111
	110	R900869020	R961006382	R961006409	R900869045	R961006436	R900869112
180	110	R900869021	R961006384	R961006411	R900869046	R961006438	R900869113
	125	R900869022	R961006385	R961006412	R900869047	R961006439	R900869114
200	125	R900869023	R961006386	R961006413	R900869048	R961006440	R900869115
	140	R900869024	R961006387	R961006414	R900869049	R961006441	R900869116

ØAL = piston Ø
ØMM = piston rod Ø

1) Seal kits for proximity switches and subplate mounting separate material no.

Seal kits ²⁾

CSH1

ØAL	ØMM	Material no. for seal design						
		M	G	V	L	T	R	S
40	28	R900861025	R961006142	R961006169	R961006072	R900861050	R961006196	R900861100
50	28	R900861026	R961006143	R961006170	R961006073	R900861051	R961006197	R900861101
	36	R900861028	R961006145	R961006172	R961006075	R900861053	R961006199	R900861103
63	36	R900861029	R961006146	R961006173	R961006076	R900861054	R961006200	R900861104
	45	R900861031	R961006148	R961006175	R961006078	R900861056	R961006202	R900861106
80	45	R900861032	R961006149	R961006176	R961006079	R900861057	R961006203	R900861107
	56	R900861034	R961006151	R961006178	R961006081	R900861059	R961006205	R900861109
100	56	R900861035	R961006152	R961006179	R961006082	R900861060	R961006206	R900861112
	70	R900861037	R961006154	R961006181	R961006084	R900861062	R961006208	R900861115
125	70	R900861038	R961006155	R961006182	R961006085	R900861063	R961006209	R900861117
	90	R900861040	R961006157	R961006184	R961006087	R900861065	R961006211	R900861122
140	90	R900861041	R961006158	R961006185	R961006088	R900861066	R961006212	R900861124
	100	R900861042	R961006159	R961006186	R961006089	R900861067	R961006213	R900861126
160	100	R900861043	R961006160	R961006187	R961006090	R900861068	R961006214	R900861128
	110	R900861044	R961006161	R961006188	R961006091	R900861069	R961006215	R900861130
180	110	R900861045	R961006163	R961006190	R961006093	R900861070	R961006217	R900861133
	125	R900861046	R961006164	R961006191	R961006094	R900861071	R961006218	R900861135
200	125	R900861047	R961006165	R961006192	R961006095	R900861072	R961006219	R900861142
	140	R900861048	R961006166	R961006193	R961006096	R900861073	R961006220	R900861143
220	140	R900888100	R961006027	R961006062	R961006097	R900888108	R961006132	R900888132
	160	R900888101	R961006028	R961006063	R961006098	R900888109	R961006133	R900888133
250	160	R900888102	R961006029	R961006064	R961006099	R900888110	R961006134	R900888134
	180	R900888103	R961006030	R961006065	R961006100	R900888111	R961006135	R900888135
280	180	R900888104	R961006031	R961006066	R961006101	R900888112	R961006136	R900888136
	200	R900888105	R961006032	R961006067	R961006102	R900888113	R961006137	R900888137
320	200	R900888106	R961006033	R961006068	R961006103	R900888114	R961006138	R900888138
	220	R900888107	-	-	R961006104	R900888115	R961006139	R900888139

ØAL = piston Ø
 ØMM = piston rod Ø

²⁾ Seal kits for position measurement system and subplate mounting separate material no.

Seal kits

Only for proximity switches

ØAL	Material no. for seal design								
	M / M+F	T / T+F	G / G+F	L	R / R+F	A	S / S+F	V / V+F	B
40 to 200	R900885938						R900885939		
220 to 320	R900894997						R900894998		

Only for subplate mounting

ØAL	Material no. for seal design	
	M, T, G, L, R, A	S, B, V
40	R961006022	R961006243
50	R961006022	R961006243
63	R961006057	R961006278
80	R961006057	R961006278
100	R961006092	R961006313
125	R961006127	R961006348
140	R961006127	R961006348
160	R961006162	R961006383
180	R961006162	R961006383
200	R961006189	R961006410

Only for position measurement system

ØAL	Material no. for seal design	
	M, T, G, L, R	S, V
40	R900885935	R900885937
50	R900894958	R900894979
63	R900894959	R900894980
80	R900894960	R900894981
100	R900894961	R900894982
125	R900894962	R900894983
140	R900894963	R900894985
160	R900894964	R900894986
180	R900894973	R900894987
200	R900894974	R900894988
220	R900894975	R900894989
250	R900894976	R900894991
280	R900894977	R900894993
320	R900894978	R900894994

ØAL = piston Ø

Tightening torques

Screws: Head and base (item 1 and 2)

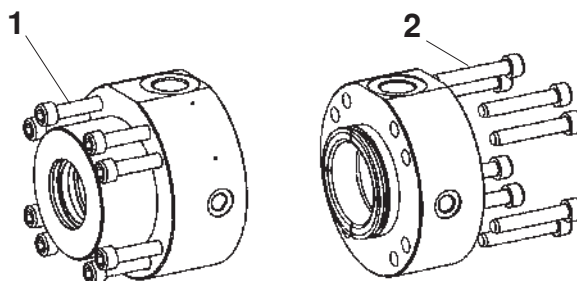

Series	Piston Ø	Screw	Quantity	Quality class	Tightening torque
CDH1 / CGH1 / CSH1	40	M8	4	10.9	23 Nm
CDH1 / CGH1 / CSH1	50	M8	8	10.9	20 Nm
CDH1 / CGH1 / CSH1	63	M8	8	10.9	30 Nm
CDH1 / CGH1 / CSH1	80	M10	8	10.9	55 Nm
CDH1 / CGH1 / CSH1	100	M12	8	10.9	100 Nm
CDH1 / CGH1 / CSH1	125	M16	8	10.9	200 Nm
CDH1 / CGH1 / CSH1	140	M16	12	10.9	170 Nm
CDH1 / CGH1 / CSH1	160	M16	12	10.9	220 Nm
CDH1 / CGH1 / CSH1	180	M20	12	10.9	350 Nm
CDH1 / CGH1 / CSH1	200	M20	12	10.9	410 Nm
CDH1 / CGH1 / CSH1	220	M20	16	10.9	460 Nm
CDH1 / CGH1 / CSH1	250	M24	16	10.9	700 Nm
CDH1 / CGH1 / CSH1	280	M24	16	10.9	800 Nm
CDH1 / CGH1 / CSH1	320	M30	16	10.9	1500 Nm

Screws: Seal cover (item 3)

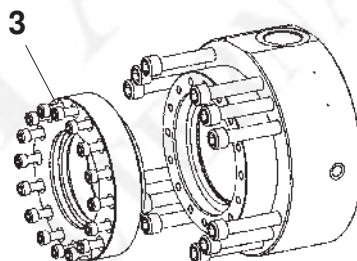

Only with seal design "A" and "B"

Series	Piston Ø	Piston rod Ø	Screw	Quantity	Quality class	Tightening torque
CDH1 / CGH1	160	100	M10	16	10.9	60 Nm
		110				
CDH1 / CGH1	180	110	M12	16	10.9	80 Nm
		125				
CDH1 / CGH1	200	125	M12	16	10.9	90 Nm
		140				
CDH1 / CGH1	220	140	M12	16	10.9	90 Nm
		160		24		
CDH1 / CGH1	250	160	M12	24	10.9	90 Nm
		180				
CDH1 / CGH1	280	180	M12	24	10.9	90 Nm
		200				
CDH1 / CGH1	320	200	M12	24	10.9	90 Nm
		220	M16	16		230 Nm

Components: Series CDH1

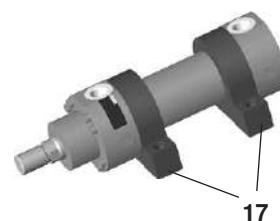
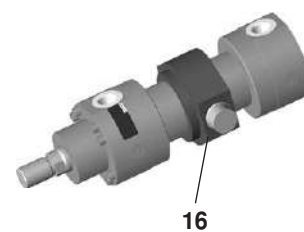
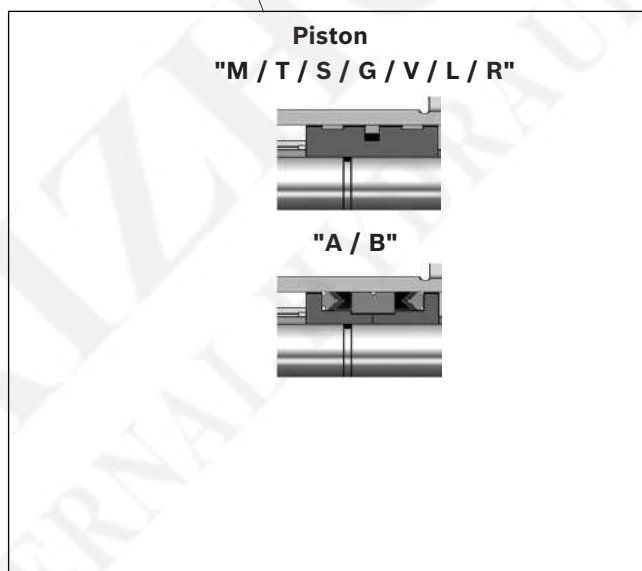
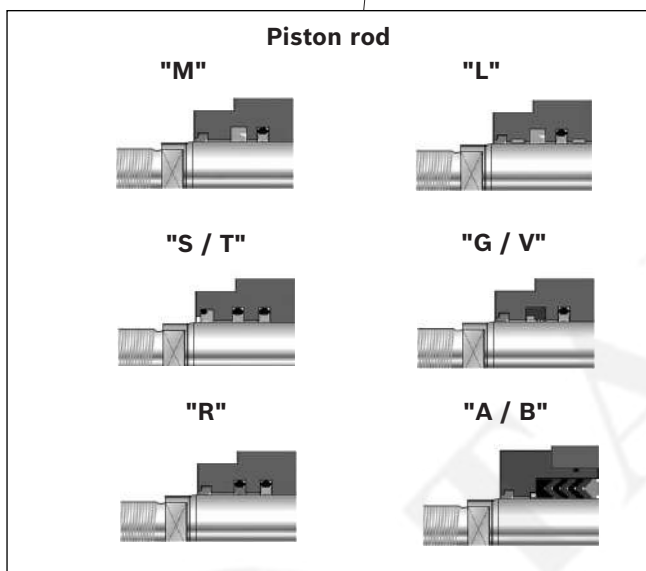
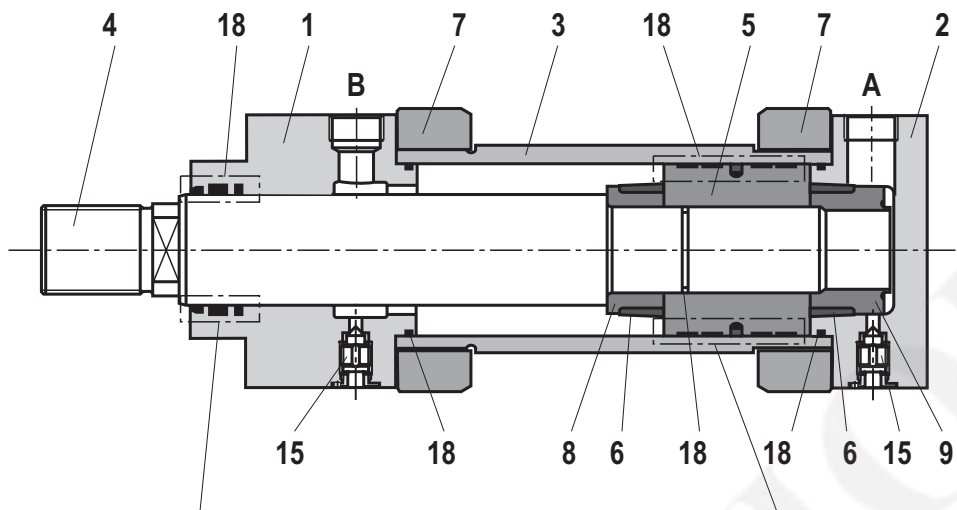

- A** Piston chamber
- B** Annulus area
- 1** Head
- 2** Base
- 3** Pipe
- 4** Piston rod

- 5** Piston
- 6** Damping bush
- 7** Flange
- 8** Socket
- 9** Socket
- 10** Base MP3

- 11** Base MP5
- 12** Round flange MF3
- 14** Round flange MF4
- 15** Bleeding
- 16** Trunnion MT4
- 17** Foot MS2

- 18** Seal kit:
- Wiper
- Rod seal
- Piston seal
- O-ring
- Guide ring

Components: Series CGH1

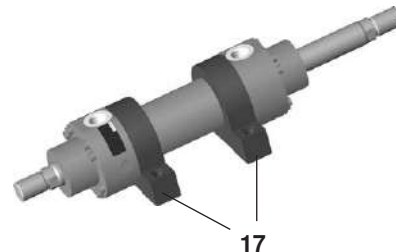
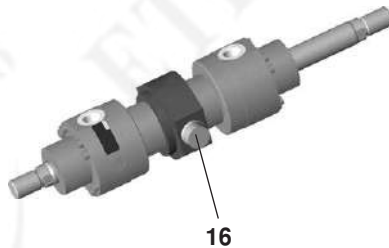
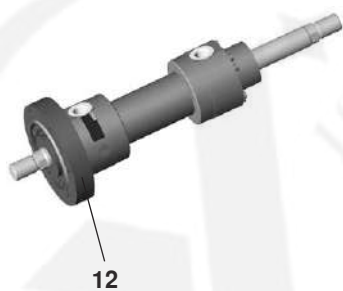
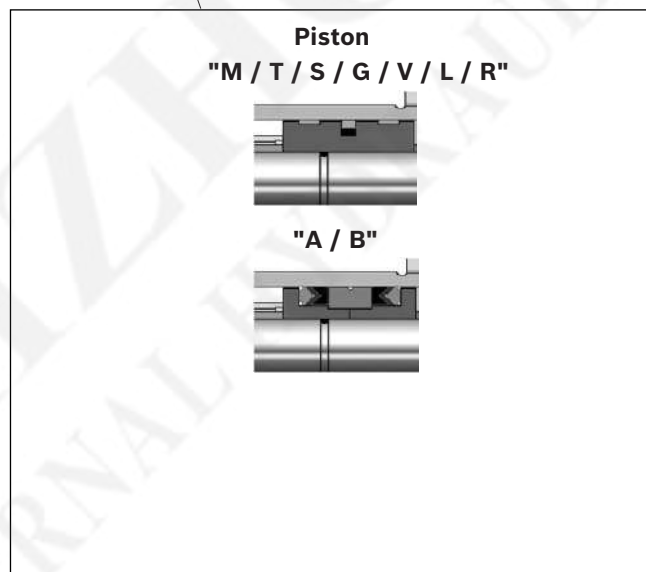
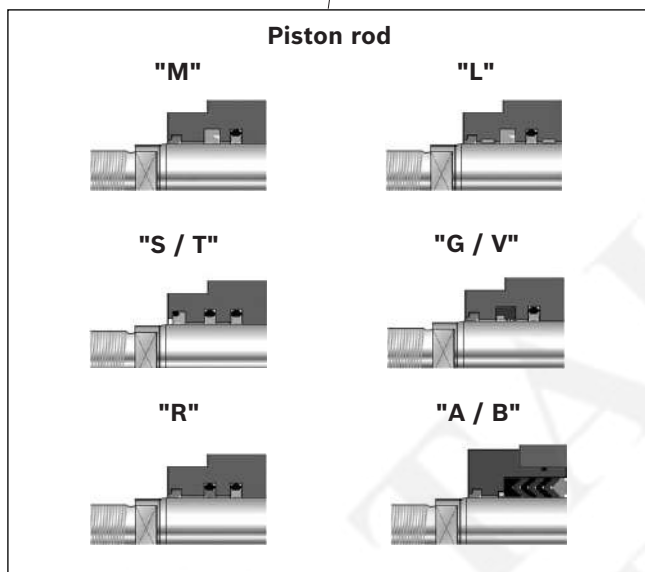
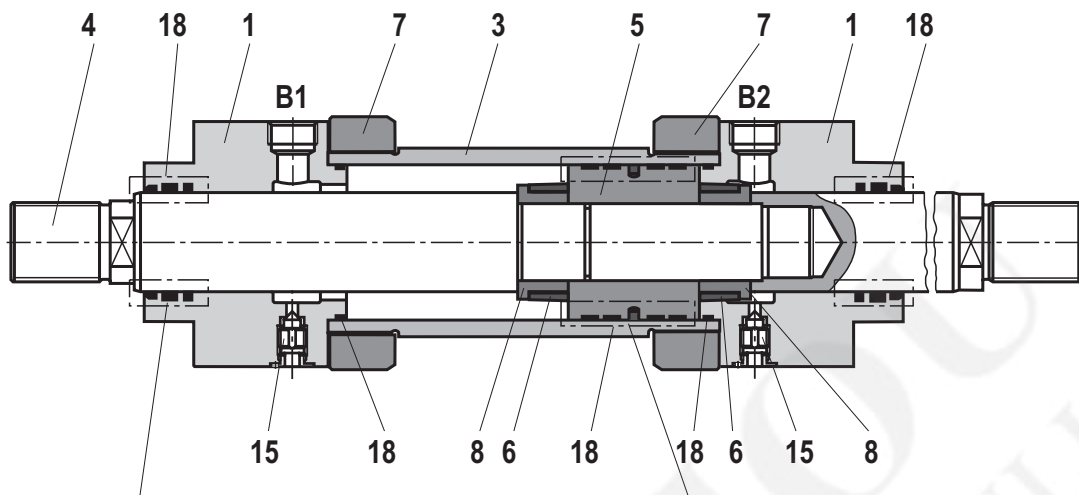

- B1** Annulus area 1
- B2** Annulus area 2
- 1** Head
- 3** Pipe
- 4** Piston rod
- 5** Piston
- 6** Damping bush
- 7** Flange
- 8** Socket

- 12** Round flange MF3
- 15** Bleeding
- 16** Trunnion MT4
- 17** Foot MS2
- 18** Seal kit:
 - Wiper
 - Rod seal
 - Piston seal
 - O-ring
 - Guide ring

Components: Series CSH1 MP3 and MP5

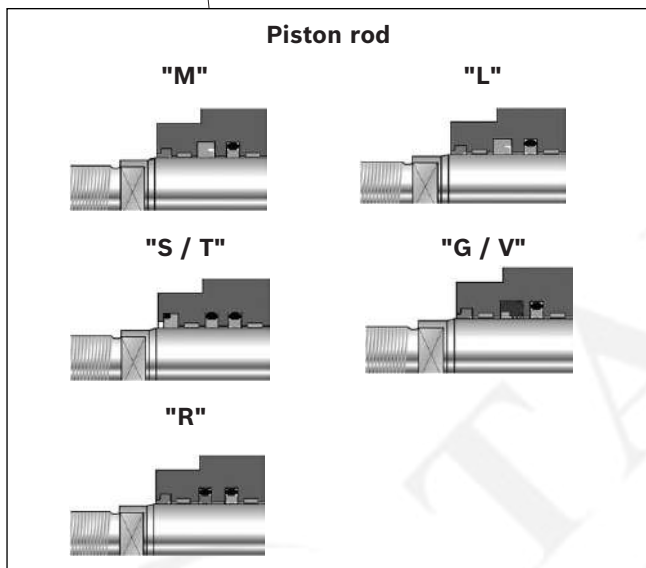
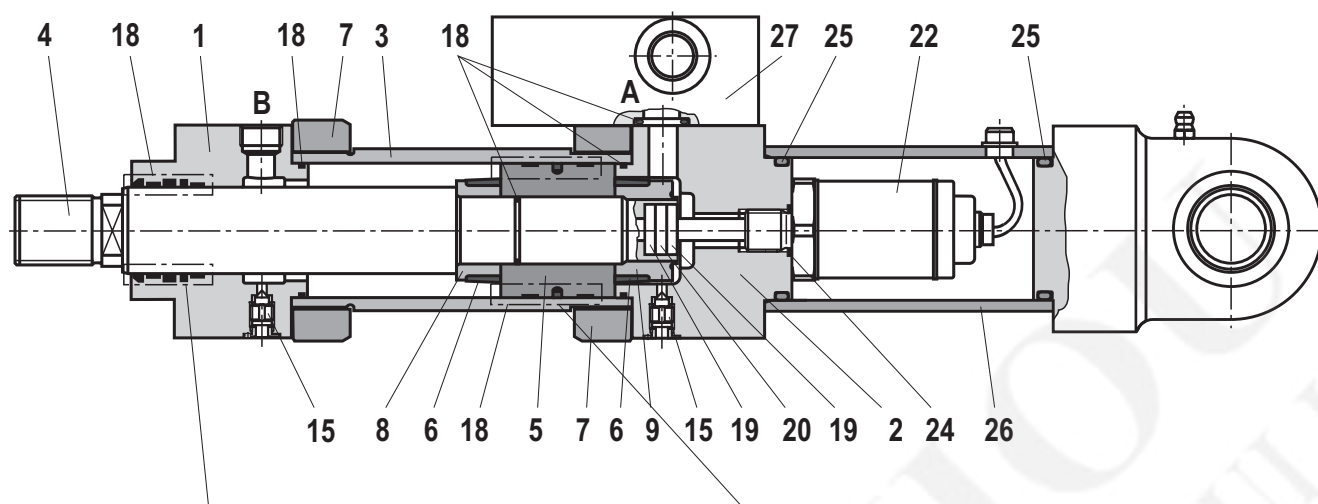

- | | | | |
|-------------------------|--------------------|-----------------------------|---------------------------------------|
| A Piston chamber | 7 Flange | 18 Seal kit: | 20 Solenoid |
| B Annulus area | 8 Socket | Wiper | 22 Position measurement system |
| 1 Head | 9 Socket | Rod seal | 24 Seal |
| 2 Base | 10 Base MP3 | Piston seal | 25 Seal |
| 3 Pipe | 11 Base MP5 | O-ring | 26 Protective pipe |
| 4 Piston rod | 15 Bleeding | Guide ring | 27 Subplate |
| 5 Piston | | 19 Insulating socket | |
| 6 Damping bush | | | |

Components: Series CSH1 MF3, MF4, MT4 and MS2

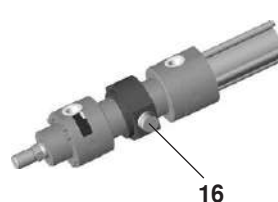
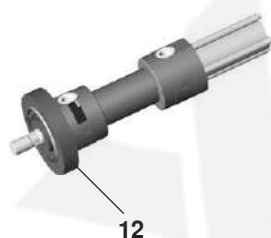
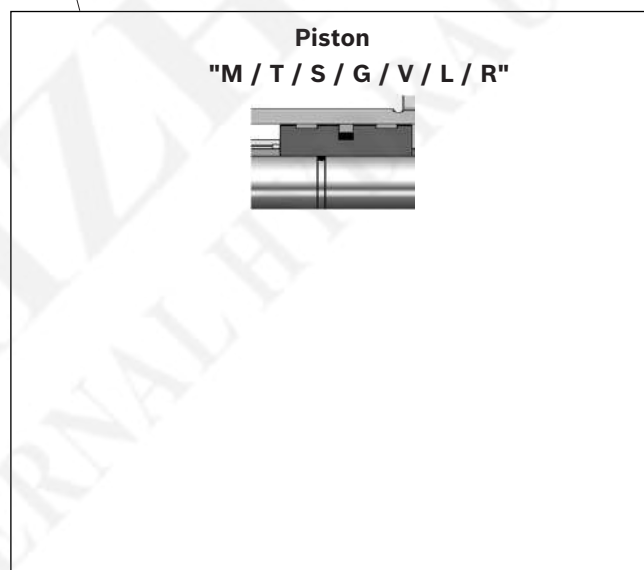
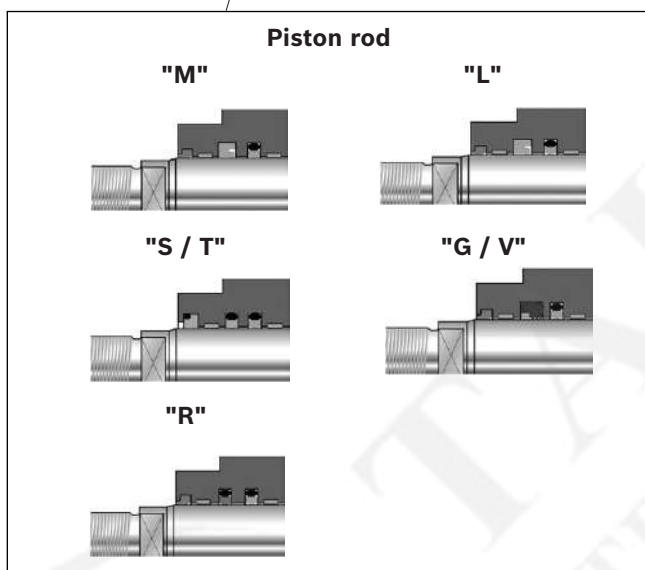
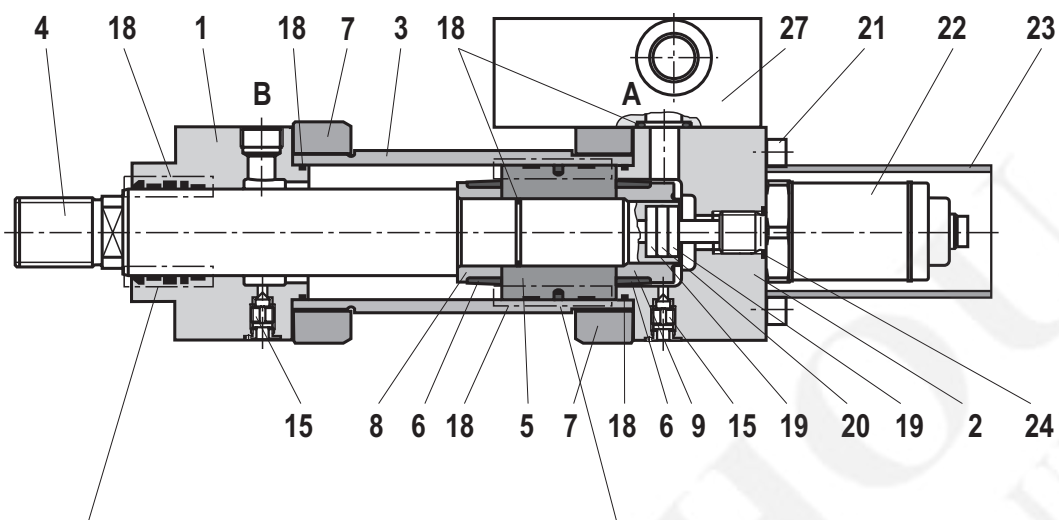

- A** Piston chamber
- B** Annulus area
- 1** Head
- 2** Base
- 3** Pipe
- 4** Piston rod
- 5** Piston
- 6** Damping bush

- 7** Flange
- 8** Socket
- 9** Socket
- 12** Round flange MF3
- 14** Round flange MF4
- 15** Bleeding
- 16** Trunnion MT4
- 17** Foot MS2

- 18** Seal kit:
 Wiper
 Rod seal
 Piston seal
 O-ring
 Guide ring
- 19** Insulating socket

- 20** Solenoid
- 21** Hexagon socket head cap screws
- 22** Position measurement system
- 23** Protective pipe
- 24** Seal
- 27** Subplate

Cylinder weight

Piston	Piston rod	CD/CS cylinder with 0 mm stroke length					per 100 mm stroke length	CG cylinder with 0 mm stroke length			per 100 mm stroke length
ØAL	ØMM	MP3 ¹⁾	MP3 ²⁾	MF3	MT4	MS2		MF3	MT4	MS2	
mm	mm	MP5 ¹⁾	MP5 ²⁾	MF4			kg	kg	kg	kg	kg
40	22	7	12	9	9	9	0.9	10	9	9	1.2
	28	7	12	9	9	9	1.0	10	9	10	1.5
50	28	10	16.5	14	12	12	1.2	15	14	14	1.6
	36	10	16.5	14	12	13	1.5	15	14	14	2.3
63	36	16	25.5	22	19	19	2.1	24	21	21	2.9
	45	16	25.5	22	19	20	2.6	24	22	22	3.8
80	45	25	35	30	29	31	2.9	34	33	35	4.1
	56	26	36	31	30	32	3.6	35	34	36	5.5
100	56	43	58.5	52	50	52	4.6	59	56	58	6.6
	70	44	59.5	53	51	53	5.7	60	58	60	8.8
125	70	79	99	93	91	90	7.3	103	101	100	10.3
	90	80	100	95	93	92	9.2	106	105	104	14.2
140	90	111	137	127	130	131	10.7	145	147	148	15.7
	100	112	138	128	131	132	11.9	146	149	150	18.1
160	100	168	205	198	200	209	12.6	230	233	241	18.8
	110	169	206	200	202	210	13.9	234	236	244	21.4
180	110	236	283	270	269	278	14.7	314	312	322	22.1
	125	239	286	272	271	281	16.8	319	318	327	26.5
200	125	306	361	348	346	358	19.0	369	367	380	28.6
	140	309	364	351	349	361	21.5	376	373	386	33.5
220	140	452	556	515	479	509	27.1	598	562	593	39.1
	160						30.9				46.7
250	160	582	710	664	618	649	32.7	784	739	770	48.5
	180						36.9				56.9
280	180	753	950	846	784	822	44.2	981	919	957	64.2
	200						48.8				73.4
320	200	1125	1404	1290	1180	1222	55.2	1452	1343	1385	79.8
	220						60.4				90.2

ØAL = piston Ø

ØMM = piston rod Ø

1) Weight without position measurement system

2) Weight with position measurement system

Corrosivity categories

In this connection, observe the information on the color set-up on page 11 "Technical data".
 Refer to the primed / painted cylinder areas, not, for example, to piston rods, trunnions, etc.
 In this connection, special measures may be necessary.

	Class	Certification by	Applications	
			Inside	Outside
Priming	CP3	240 h salt spray test SST (DIN EN ISO 9227) 240 h condensation water test KKT (DIN EN ISO 6270-2) Layer thickness: min. 40 µm	Field of application, e.g. Hall atmosphere, Air humidity ≤ 60%, no thermal load.	Not suitable for outdoor exposure.
Painting	CP4	480 h salt spray test SST. (DIN EN ISO 9227) 480 h condensation water test KKT (DIN EN ISO 6270-2) Nominal layer thickness: 120 µm	Unheated buildings in which there may be condensation (production rooms, storage and sport halls).	Urban and industrial atmosphere with little salt or sulfur dioxide load.
	CP5	720 h salt spray test SST (DIN EN ISO 9227) 480 h condensation water test KKT (DIN EN ISO 6270-2) Nominal layer thickness: 140 µm	Silo and debris facilities, chemical plants, boathouses above sea water, laundries, breweries with high humidity and medium contamination.	Industrial and coastal areas with medium salt load.
	CP6	1000 h salt spray test NSS (DIN EN ISO 9227) 480 h condensation water test KKT (DIN EN ISO 6270-2) Nominal layer thickness: 220 µm	Buildings or areas with almost permanent condensation and serious contamination.	Industrial areas with large humidity and aggressive atmosphere.
	CP7	1440 h salt spray test NSS (DIN EN ISO 9227) 720 h condensation water test KKT (DIN EN ISO 6270-2) Nominal layer thickness: 320 µm	Buildings or areas with almost permanent condensation and with serious contamination.	Coastal and offshore areas with high salt load.