

型号 Model	排量 (ml/r)	最小进 口流量 750rpm (L/M)	标准进 口流量 1500rpa (L/M)	最大进 口流量 3000rpa (L/M)	出油口 最大压力 (Mpa)	油口	
						进油口 Inlet	出油口 Outlet
FMA(T)-2*2.1*	2.17	3.26	6.51	13.02	25	M27 × 2 G1/2 PT1/2	M18 × 1.5 G3/8 PT3/8
FMA(T)-2*3*	3.18	4.77	9.54	19.08			
FMA(T)-2*4.2*	4.34	6.51	13.02	26.04			
FMA(T)-2*6.3*	6.37	9.56	19.11	38.22			
FMA(T)-2*8.8*	8.82	13.23	26.46	52.92			

2、FMA- 3 R ** - *

液压原理图
Hydraulic Schematic

型号规格	L	H
FMA3-20	203.5	243.5
FMA3-40	226	266
FMA3-80	272.5	312.5

(FMAT- 3 R ** - *)

液压原理图
Hydraulic Schematic

型号规格	L	H
FMAT3R-20	203.5	243.5
FMAT3R-40	226	266
FMAT3R-80	272.5	312.5

型号 Model	排量 (ml/r)	最小进 口流量 750rpm (L/M)	标准进 口流量 1500rpa (L/M)	最大进 口流量 3000rpa (L/M)	出油口 最大压力 (Mpa)	油口	
						进油口 Inlet	出油口 Outlet
FMA(T)-3*2.1*	2.17	4.89	9.46	18.62	25	M27 × 2 G1/2 PT1/2	M18 × 1.5 G3/8 PT3/8
FMA(T)-3*3*	3.18	7.2	14	28			
FMA(T)-3*4.2*	4.34	9.7	19.32	38			
FMA(T)-3*6.3*	6.37	14.34	28.1	55.9			
FMA(T)-3*8.8*	8.82	20	41	82			

3、FMA- 4 R ** - *

液压原理图
Hydraulic Schematic

型号规格	L	H
FMA4-20	247	287
FMA4-40	277	317
FMA4-80	339	379

(FMAT- 4 R ** - *)

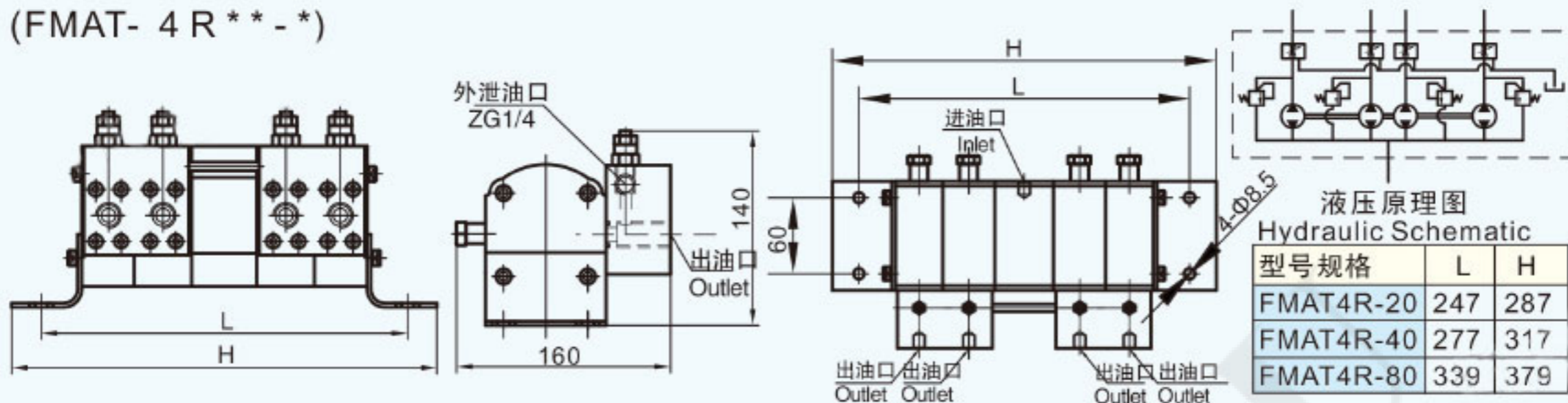

型号 Model	排量 (ml/r)	最小进口流量 750rpm (L/M)	标准进口流量 1500rpm (L/M)	最大进口流量 3000rpm (L/M)	出油口 最大压力 (Mpa)	油口	
						进油口 Inlet	出油口 Outlet
FMA(T)-4*2.1*	2.17	6.51	13.2	26.04	21	M33 × 2 G3/4 PT3/4	M18 × 1.5 G1/2 PT1/2
FMA(T)-4*3*	3.18	9.54	19.08	38.16			
FMA(T)-4*4.2*	4.34	13.02	26.04	52.08			
FMA(T)-4*6.3*	6.37	19.11	38.22	76.44			
FMA(T)-4*8.8*	8.82	26.46	52.92	105.84			

4、FMA- 5 R ** - *

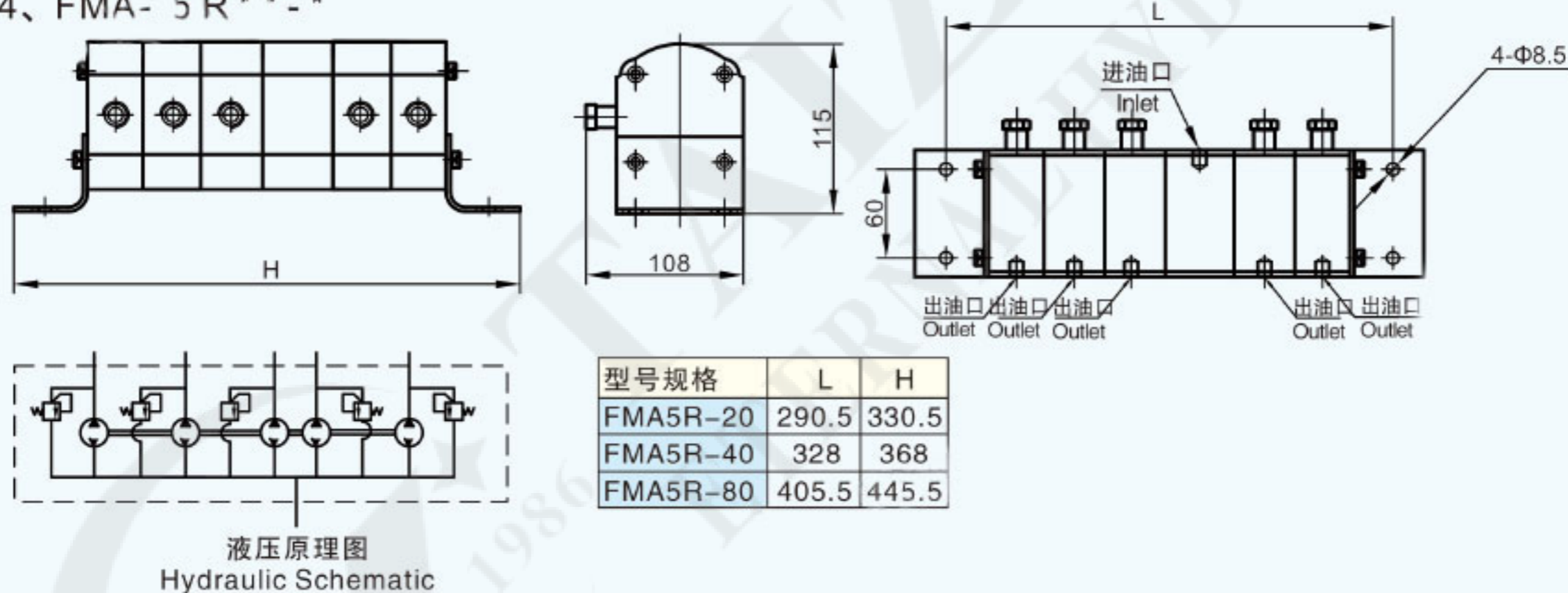

(FMAT- 5 R ** - *)

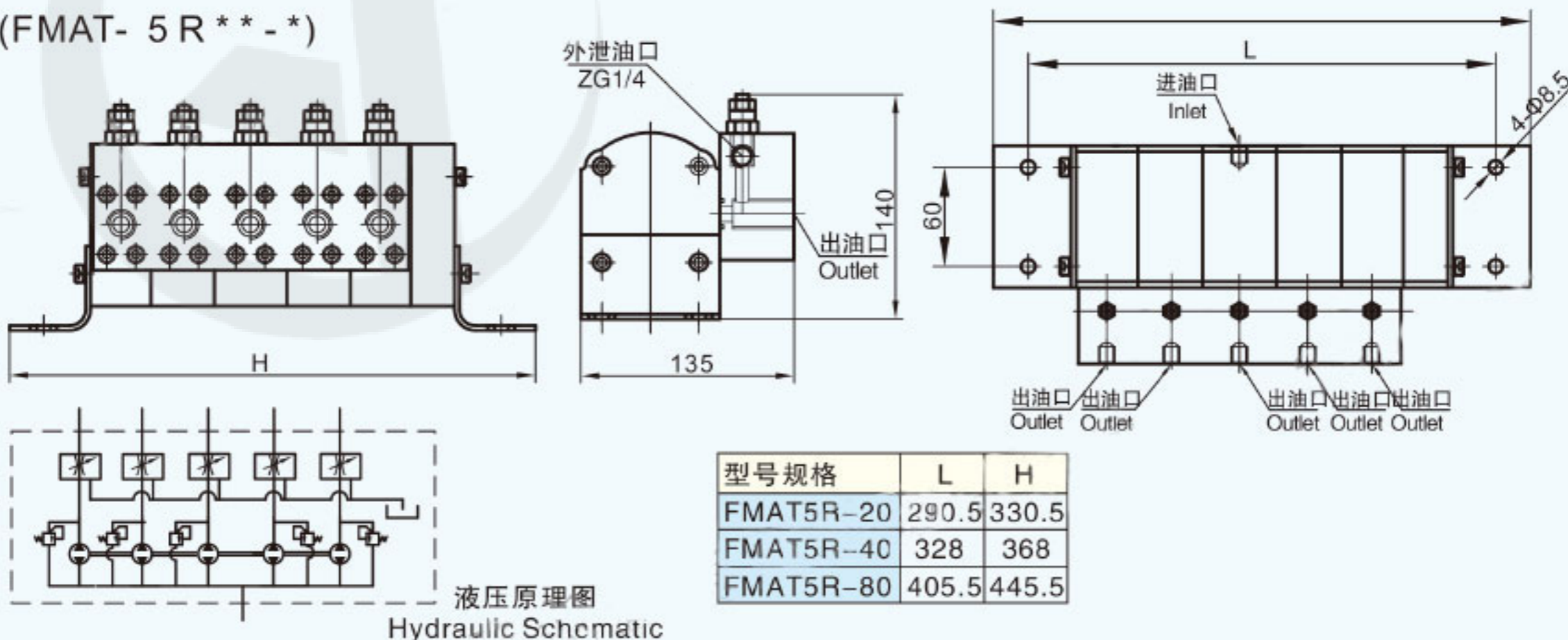

型号 Model	排量 (ml/r)	最小进口流量 750rpm (L/M)	标准进口流量 1500rpm (L/M)	最大进口流量 3000rpm (L/M)	出油口 最大压力 (Mpa)	油口	
						进油口 Inlet	出油口 Outlet
FMA(T)-5*2.1*	2.17	8.15	16.2	32.08	21	M33 × 2 G1 PT1	M18 × 1.5 G3/8 PT3/8
FMA(T)-5*3*	3.18	11.9	23.8	47.6			
FMA(T)-5*4.2*	4.34	16.3	32.6	65			
FMA(T)-5*6.3*	6.37	23.88	47.7	95.5			
FMA(T)-5*8.8*	8.82	33.07	66.1	132.1			

5、FMA- 6 R ** - *

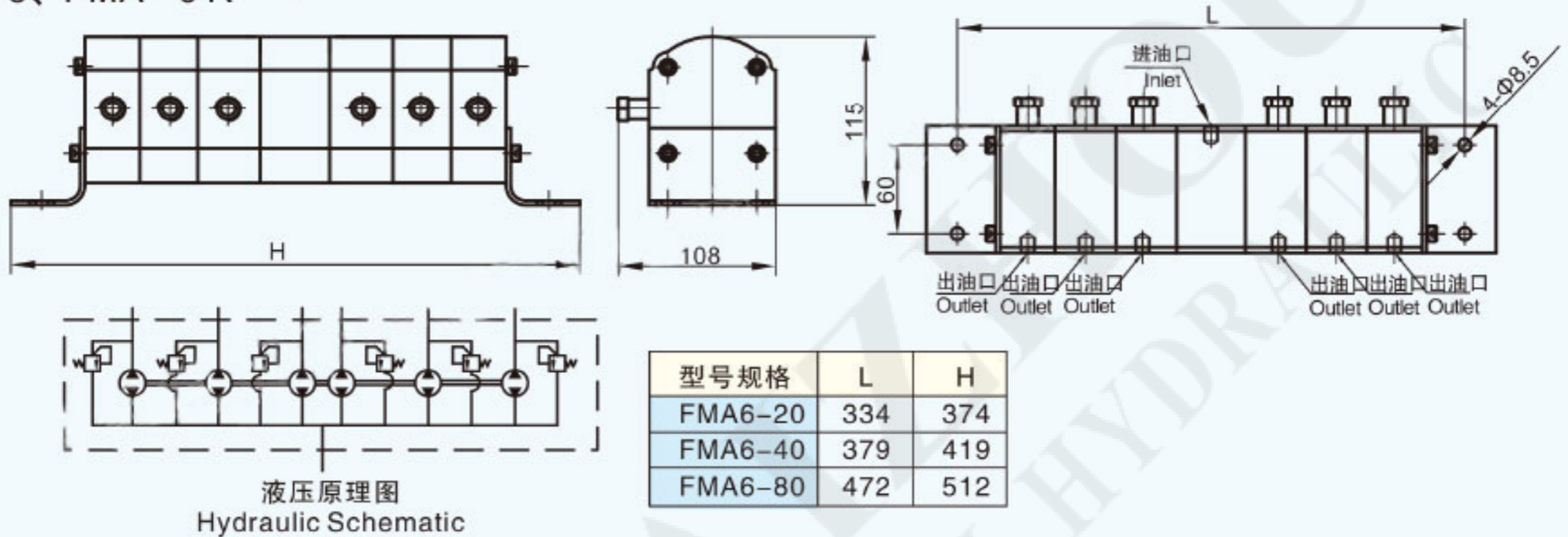

(FMAT- 6 R ** - *)

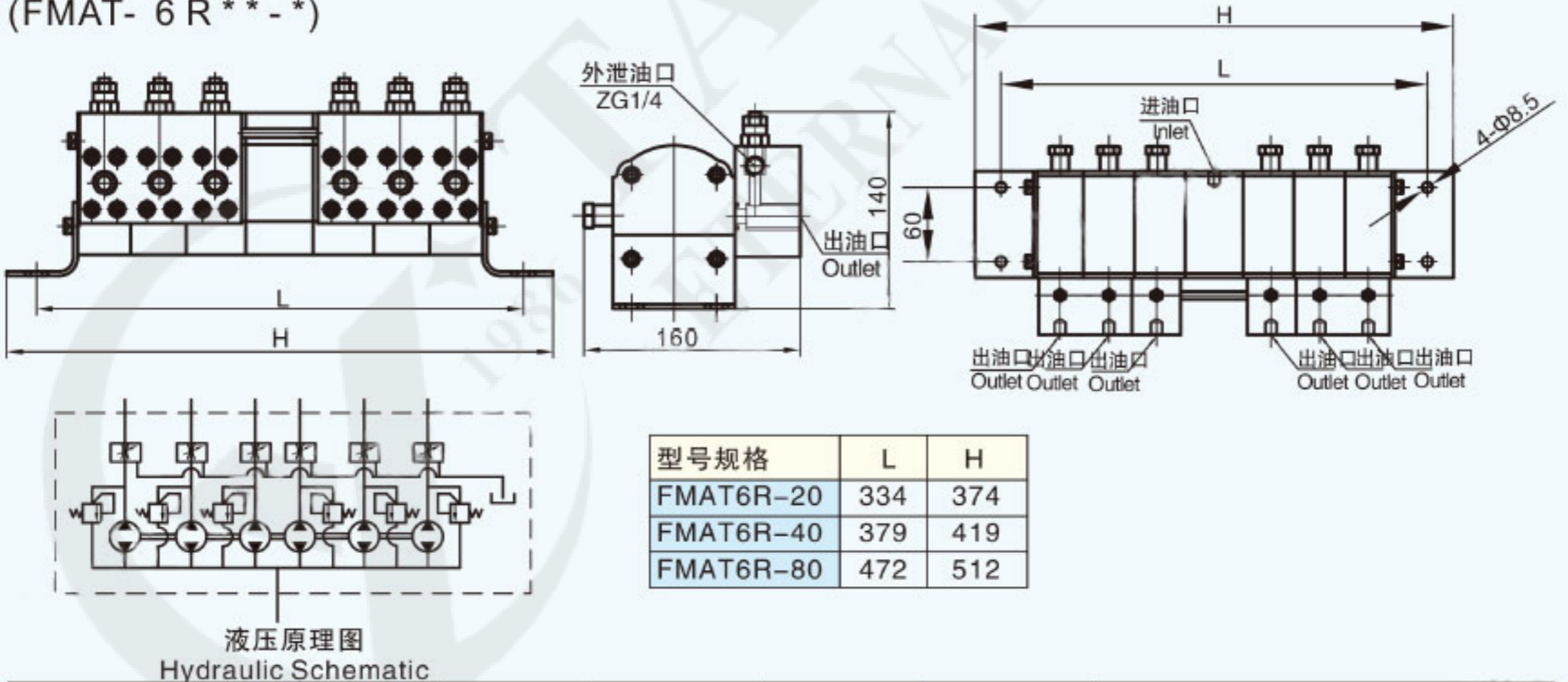

型号 Model	排量 (ml/r)	最小进口流量 750rpm (L/M)	标准进口流量 1500rpm (L/M)	最大进口流量 3000rpm (L/M)	出油口 最大压力 (Mpa)	油口	
						进油口 Inlet	出油口 Outlet
FMA(T)-6*2.1*	2.17	9.45	18.89	37.8	21	M33 × 2 G1 PT1	M18 × 1.5 G3/8 PT3/8
FMA(T)-6*3*	3.18	14.31	28.6	57.2			
FMA(T)-6*4.2*	4.34	19.53	39	78			
FMA(T)-6*6.3*	6.37	28.6	57.2	114.4			
FMA(T)-6*8.8*	8.82	39.6	79.4	158.7			

四、MMA系列同步马达

四、Mma Series Synchronous Motor

■ 型号说明 Model Coding

MMA - $\frac{*}{①}$ $\frac{*}{②}$ $\frac{*}{③}$ $\frac{*}{④}$ - $\frac{*}{⑤}$



- ① 分配室数目 Number of section: 2、3、4、5、6、7、8、9、10
- ② 溢流阀 relief valve: R带溢流阀 With relief valve N不带溢流阀 Without relief valve
- ③ 分配室排量 Displacement of each section: 0.061-0.5370 in³/r 1.0-8.8cc/r
- ④ 油口形式 Ports configuration: M 公制螺纹油口 M Ports PT 油口 PT Ports
G 管螺纹 BSPP Ports
- ⑤ 细节描述 Detailed description

■ 外形图 Outline Dimensions

1、MMA-2R**-*

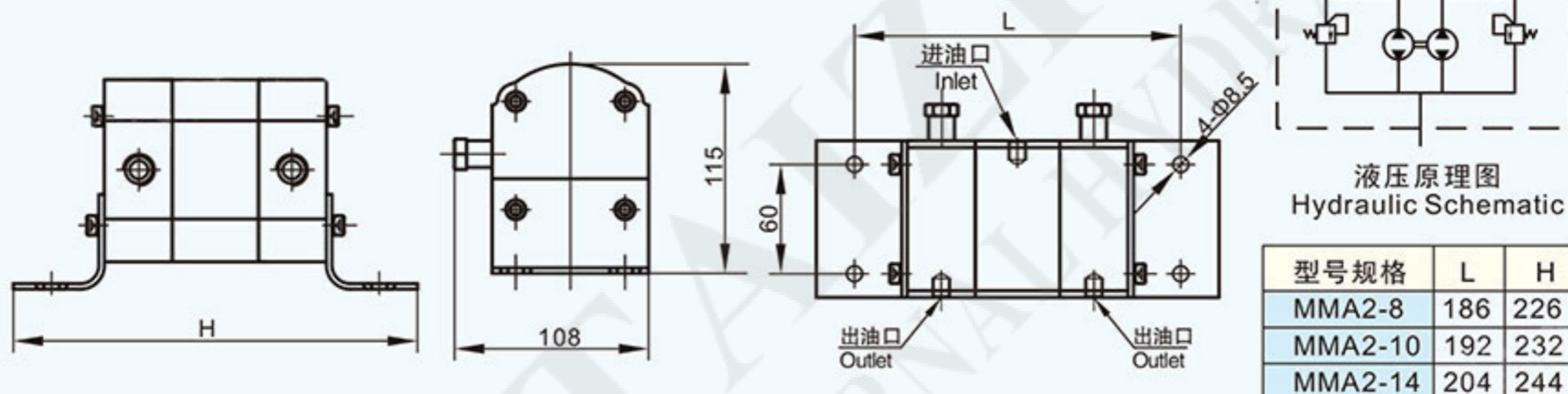

型号 Model	排量 (ml/r)	最小进口流量 750rpm (L/M)	标准进口流量 1500rpa (L/M)	最大进口流量 3000rpa (L/M)	出油口最大 压力 (Mpa)	油口Oil port	
						进油口Inlet	出油口Outlet
MMA2R-8	8	12	24	48	21	M22 × 1.5 PT 1/2	M18 × 1.5 PT 3/8
MMA2R-10	10	15	30	60		M27 × 2 PT 3/4	M22 × 1.5 PT 1/2
MMA2R-14	14	21	42	84		M33 × 2 PT 1	M22 × 1.5 PT 1/2

2、MMA-3R**-*

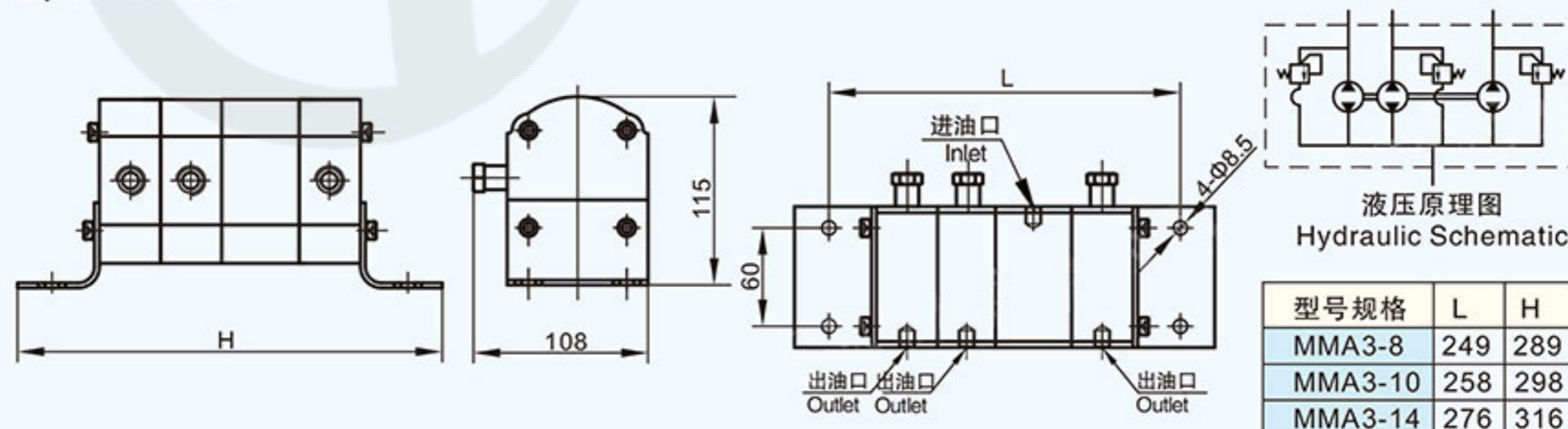

型号 Model	排量 (ml/r)	最小进口流量 750rpm (L/M)	标准进口流量 1500rpa (L/M)	最大进口流量 3000rpa (L/M)	出油口最大 压力(Mpa)	油口Oil port	
						进油口Inlet	出油口Outlet
MMA3R-8	8	18	36	72	21	M33 × 2 PT 1	M22 × 1.5 PT 1/2
MMA3R-10	10	22.5	45	90		M33 × 2 PT 1	M22 × 1.5 PT 1/2
MMA3R-14	14	31.5	63	126		M33 × 2 PT1 1/4	M27 × 2 PT 3/4

3、MMA-4R ** - *

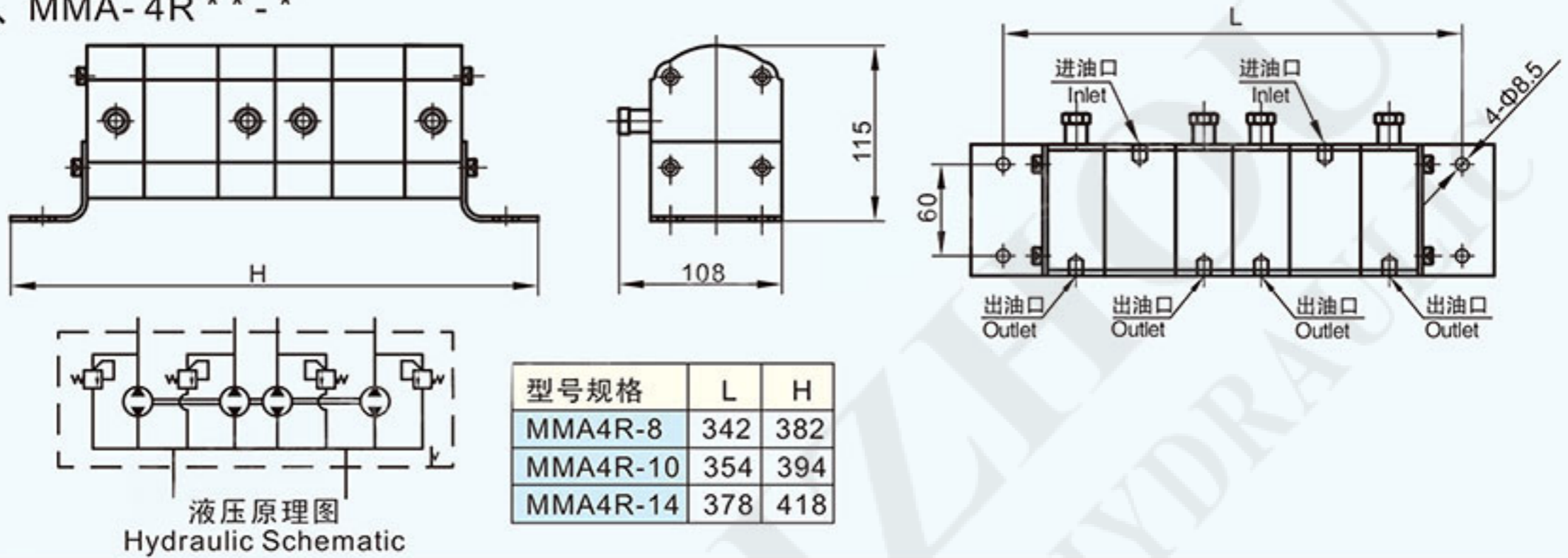

型号 Model	排量 (ml/r)	最小进口流量 750rpm (L/M)	标准进口流量 1500rpa (L/M)	最大进口流量 3000rpa (L/M)	出油口最大 压力(Mpa)	油口Oil port	
						进油口Inlet	出油口Outlet
MMA4R-8	8	24	48	96	21	M22 × 1.5 PT 1/2	M18 × 1.5 PT 3/8
MMA4R-10	10	30	60	120		M27 × 2 PT 3/4	M22 × 1.5 PT 1/2
MMA4R-14	14	42	84	168		M33 × 2 PT 1	M22 × 1.5 PT 1/2

4、MMA-5R ** - *

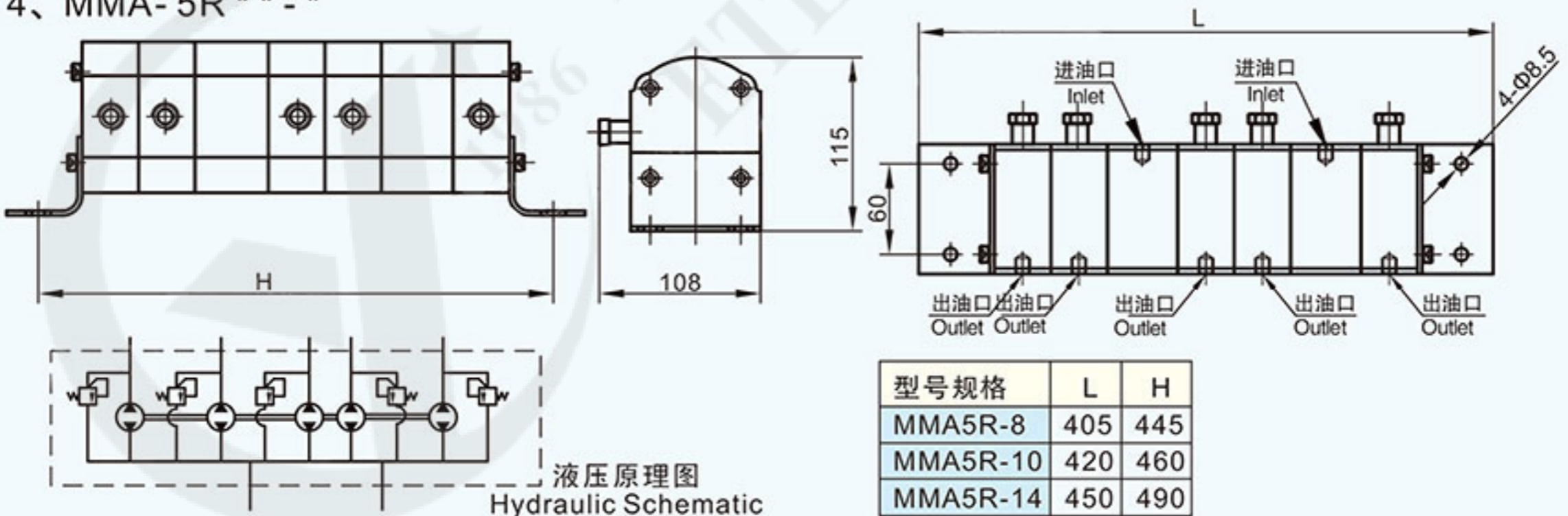

型号 Model	排量 (ml/r)	最小进口流量 750rpm (L/M)	标准进口流量 1500rpa (L/M)	最大进口流量 3000rpa (L/M)	出油口最大 压力(Mpa)	油口Oil port	
						进油口Inlet	出油口Outlet
MMA5R-8	8	30	60	120	21	M33 × 2 PT 1	M22 × 1.5 PT 1/2
MMA5R-10	10	37.5	75	150		M33 × 2 PT 1	M22 × 1.5 PT 1/2
MMA5R-14	14	52.5	105	210		M42 × 2 PT1 1/4	M27 × 2 PT 3/4

5、MMA-6R**-*

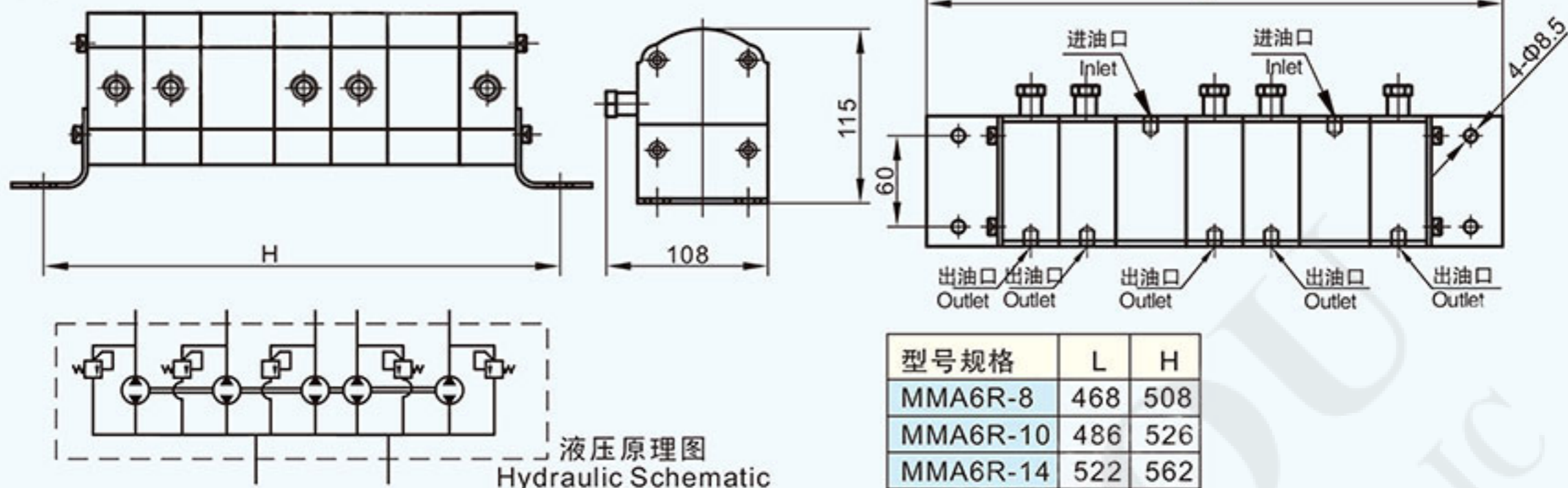

型号 Model	排量 (ml/r)	最小进口流量 750rpm (L/M)	标准进口流量 1500rpm (L/M)	最大进口流量 3000rpm (L/M)	出油口最大 压力(Mpa)	油口Oil port	
						进油口Inlet	出油口Outlet
MMA6R-8	8	36	72	144	21	M33 × 2 PT 1	M22 × 1.5 PT 1/2
MMA6R-10	10	45	90	180		M33 × 2 PT 1	M22 × 1.5 PT 1/2
MMA6R-14	14	63	126	252		M42 × 2 PT 1 1/4	M27 × 2 PT 3/4

MMA*R-**中排量马达进油形式/MMA*R-** Oil inlet form of medium displacement motor

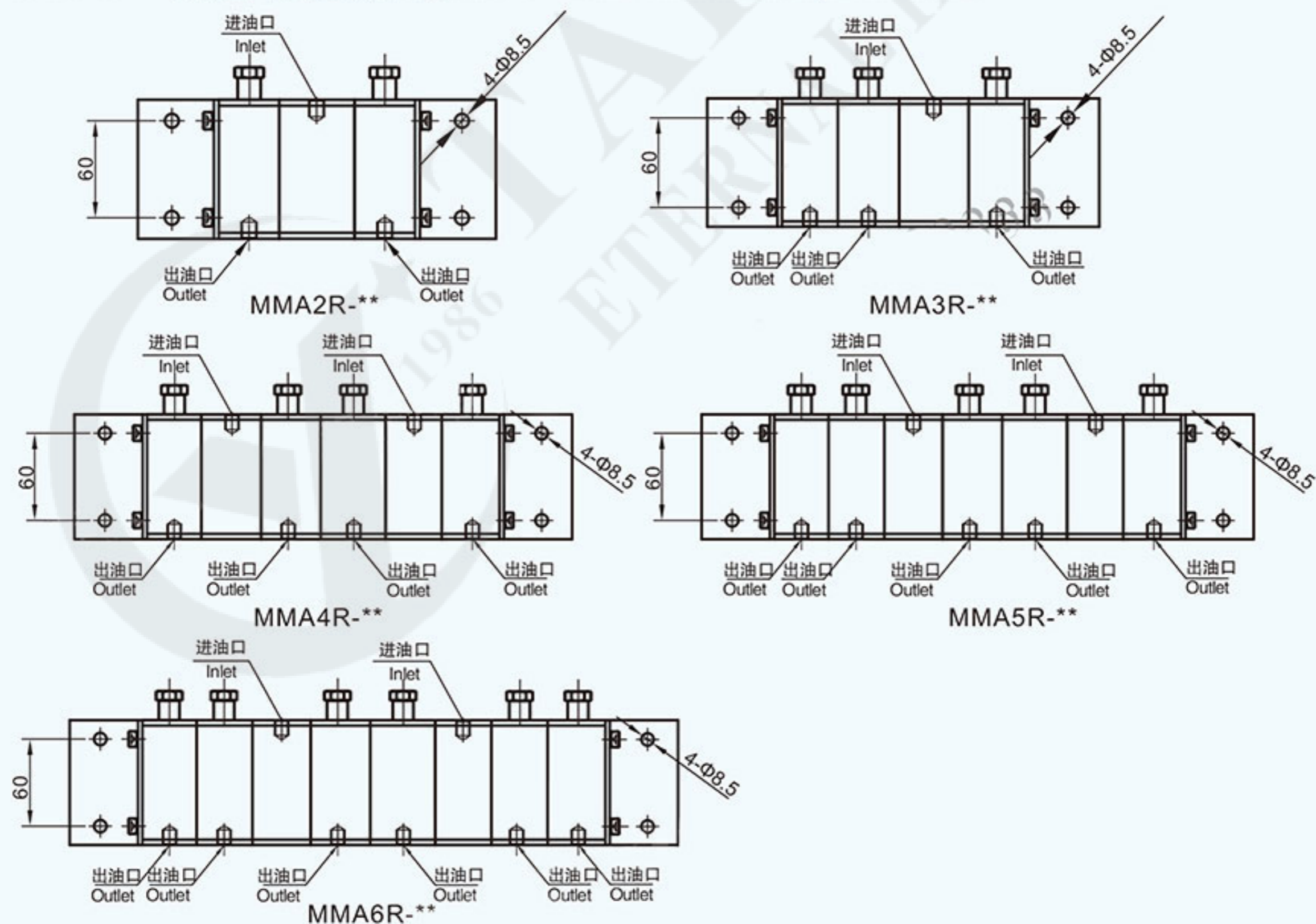

五、VCJ系列同步马达

五、VCJ Series Synchronous Motor

■ 型号说明 Model Coding

VCJ - * R - * - VR 160

① ② ③ ④ ⑤ ⑥

- ①大排量分流马达 Large displacement shunt motor
- ②片数/联数 Number of pieces
- ③片数/联数代号 Number code
- ④排量或者流量 Displacement or flow
- ⑤带溢流阀 With relief valve
- ⑥溢流阀设定压力 Set pressure of relief valve



■ 外形图 Outline Dimensions

1、VCJ2R-**

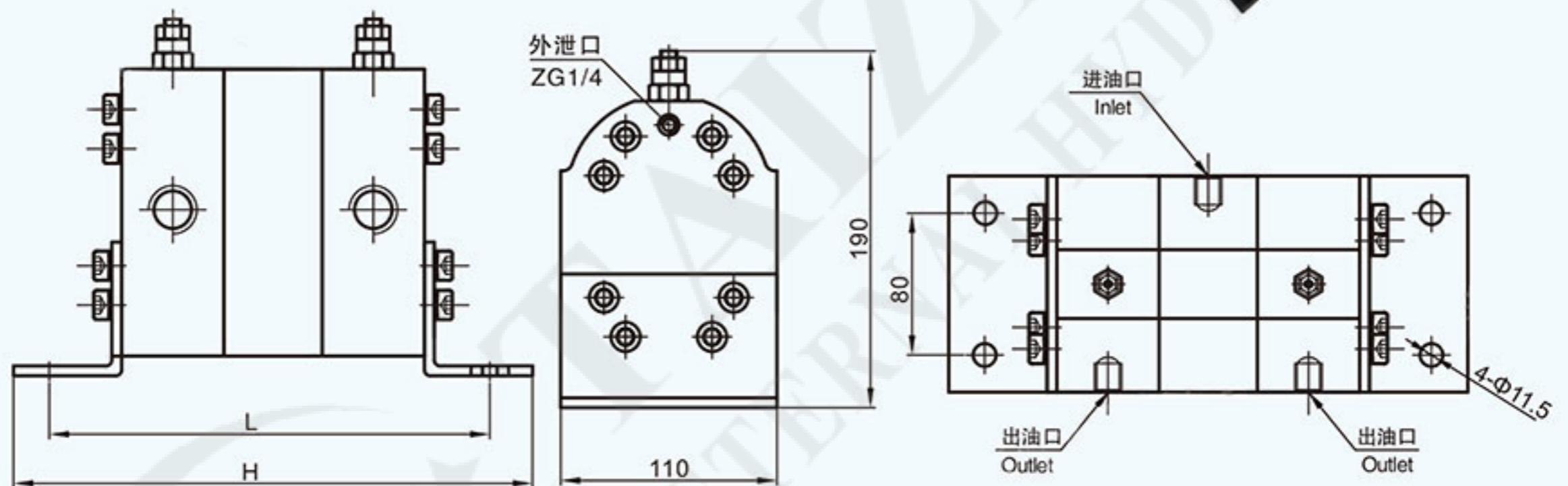

型号规格	L	H
VCJ2R-14	224	264
VCJ2R-20	244	284
VCJ2R-25	258	298
VCJ2R-30	274	314

型号 Model	排量 (ml/r)	最小进口流量 750rpm (L/M)	标准进口流量 1500rpm (L/M)	最大进口流量 3000rpm (L/M)	出油口最大 压力(Mpa)	油口Oil port	
						进油口Inlet	出油口Outlet
VCJ2R-14	14	21	42	84	21	M27 × 2 PT 3/4	M22 × 1.5 PT 1/2
VCJ2R-20	20	30	60	120		M27 × 2 PT 3/4	M22 × 1.5 PT 1/2
VCJ2R-25	25	37.5	75	150		M33 × 2 PT1	M22 × 1.5 PT 1/2
VCJ2R-30	30	45	90	180		M33 × 2 PT1	M22 × 1.5 PT 1/2

2、VCJ3R-**

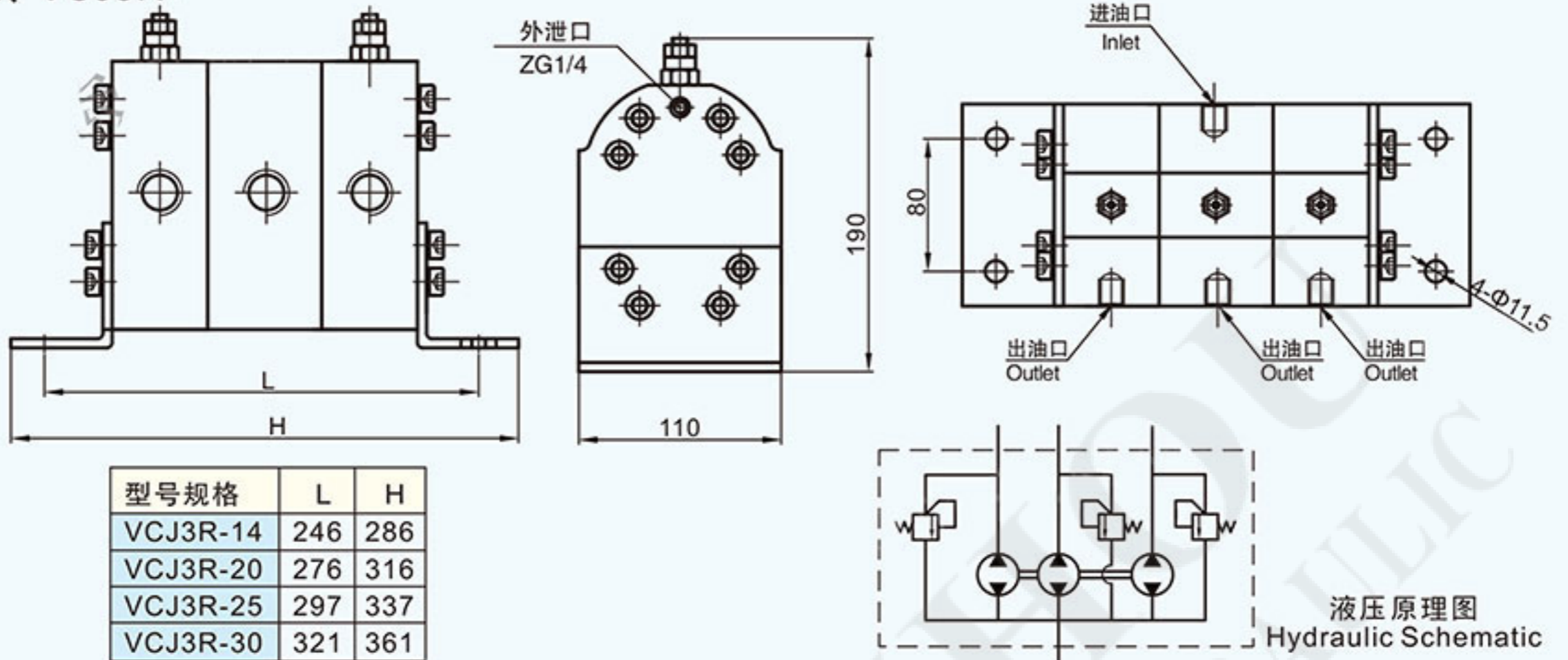

型号规格	L	H
VCJ3R-14	246	286
VCJ3R-20	276	316
VCJ3R-25	297	337
VCJ3R-30	321	361

型号 Model	排量 (ml/r)	最小进口流量 750rpm (L/M)	标准进口流量 1500rpa (L/M)	最大进口流量 3000rpa (L/M)	出油口最大 压力(Mpa)	油口Oil port	
						进油口Inlet	出油口Outlet
VCJ3R-14	14	31.5	63	126	21	M33 × 2 PT 1	M22 × 1.5 PT 1/2
VCJ3R-20	20	45	90	180		M33 × 2 PT 1	M22 × 1.5 PT 1/2
VCJ3R-25	25	56	112	224		M42 × 2 PT1 1/4	M27 × 2 PT 3/4
VCJ3R-30	30	67.5	135	270		M42 × 2 PT1 1/4	M27 × 2 PT 3/4

3、VCJ4R-**

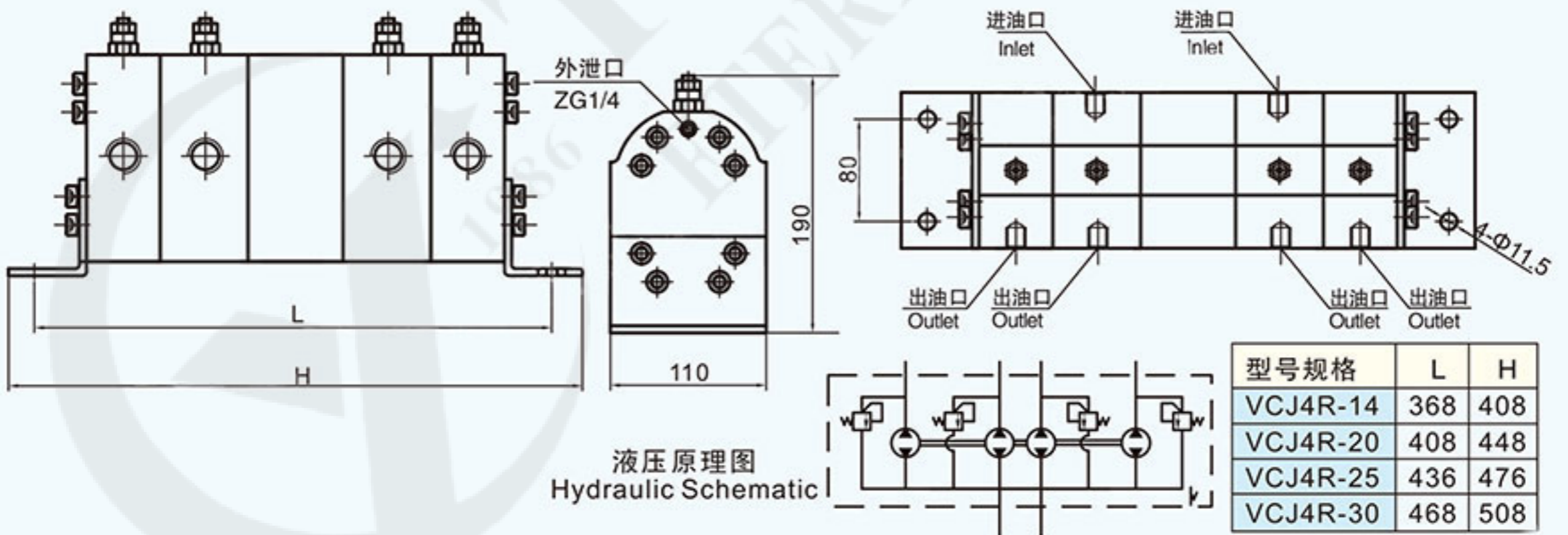

型号规格	L	H
VCJ4R-14	368	408
VCJ4R-20	408	448
VCJ4R-25	436	476
VCJ4R-30	468	508

型号 Model	排量 (ml/r)	最小进口流量 750rpm (L/M)	标准进口流量 1500rpa (L/M)	最大进口流量 3000rpa (L/M)	出油口最大 压力(Mpa)	油口Oil port	
						进油口Inlet	出油口Outlet
VCJ4R-14	14	42	84	168	21	M27 × 2 PT 3/4	M22 × 1.5 PT 1/2
VCJ4R-20	20	60	120	240		M27 × 2 PT 3/4	M22 × 1.5 PT 1/2
VCJ4R-25	25	75	150	300		M33 × 2 PT1	M22 × 1.5 PT 1/2
VCJ4R-30	30	90	180	360		M33 × 2 PT1	M22 × 1.5 PT 1/2

4、VCJ5R-**

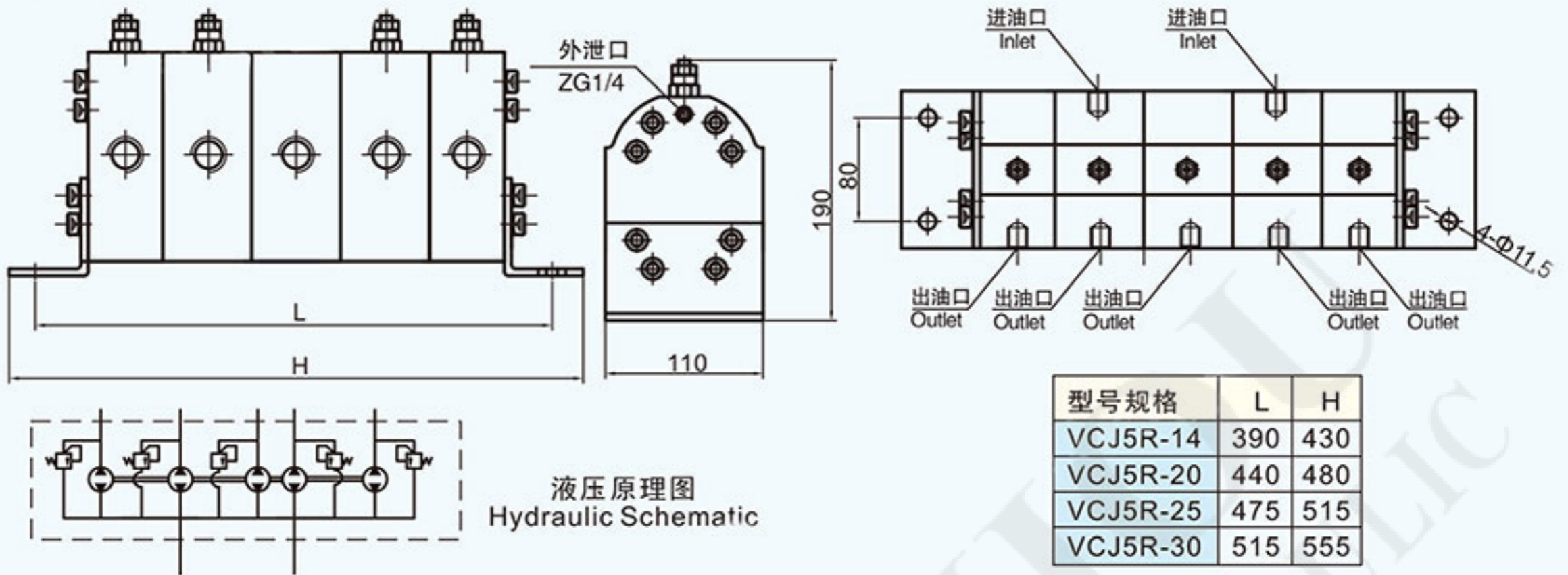

型号 Model	排量 (ml/r)	最小进口流量 750rpm (L/M)	标准进口流量 1500rpa (L/M)	最大进口流量 3000rpa (L/M)	出油口最大 压力(Mpa)	油口Oil port	
						进油口Inlet	出油口Outlet
VCJ5R-14	14	63	104	208	21	M33 × 2 PT 1	M22 × 1.5 PT 1/2
VCJ5R-20	20	75	150	300		M33 × 2 PT 1	M22 × 1.5 PT 1/2
VCJ5R-25	25	93	186	372		M42 × 2 PT1 1/4	M27 × 2 PT 3/4
VCJ5R-30	30	112	224	448		M42 × 2 PT1 1/4	M27 × 2 PT 3/4

5、VCJ6R-**

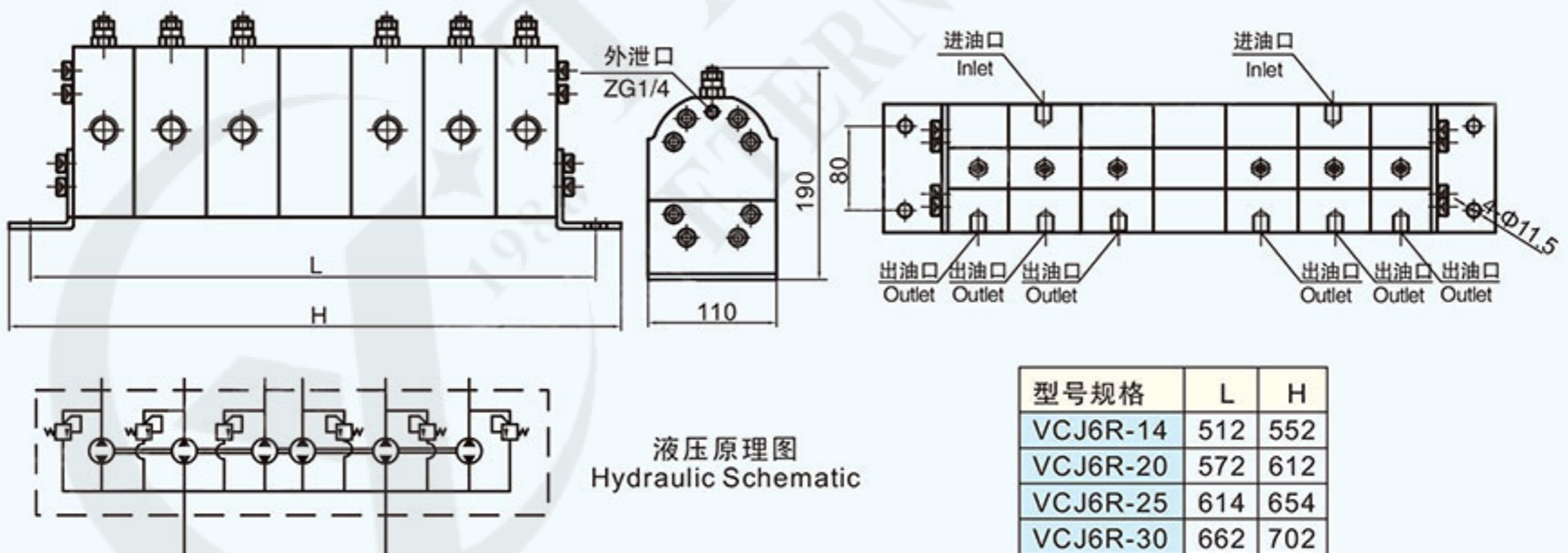

型号 Model	排量 (ml/r)	最小进口流量 750rpm (L/M)	标准进口流量 1500rpa (L/M)	最大进口流量 3000rpa (L/M)	出油口最大 压力(Mpa)	油口Oil port	
						进油口Inlet	出油口Outlet
VCJ6R-14	14	63	126	252	21	M33 × 2 PT 1	M22 × 1.5 PT 1/2
VCJ6R-20	20	90	180	360		M33 × 2 PT 1	M22 × 1.5 PT 1/2
VCJ6R-25	25	112	224	448		M42 × 2 PT1 1/4	M27 × 2 PT 3/4
VCJ6R-30	30	135	270	540		M42 × 2 PT1 1/4	M27 × 2 PT 3/4

VCJ*R-**大排量马达进油形式/VCJ*R-** large displacement motor oil inlet form

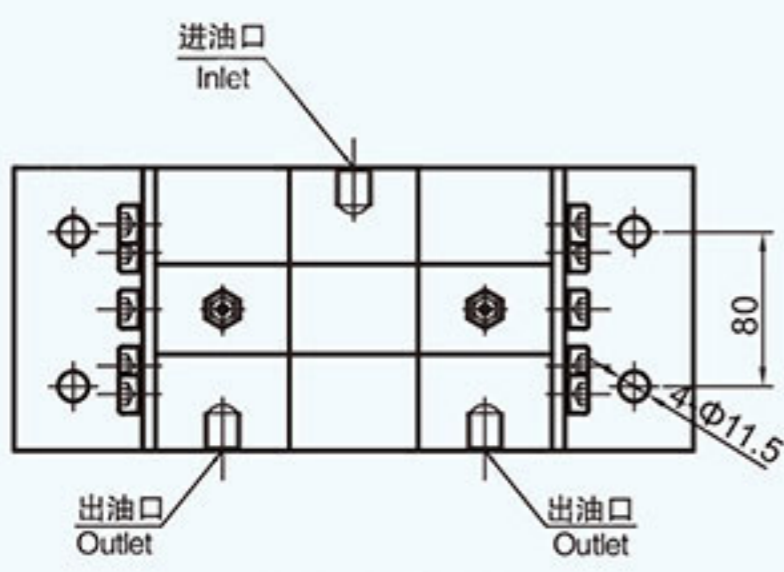

VCJ2R-**

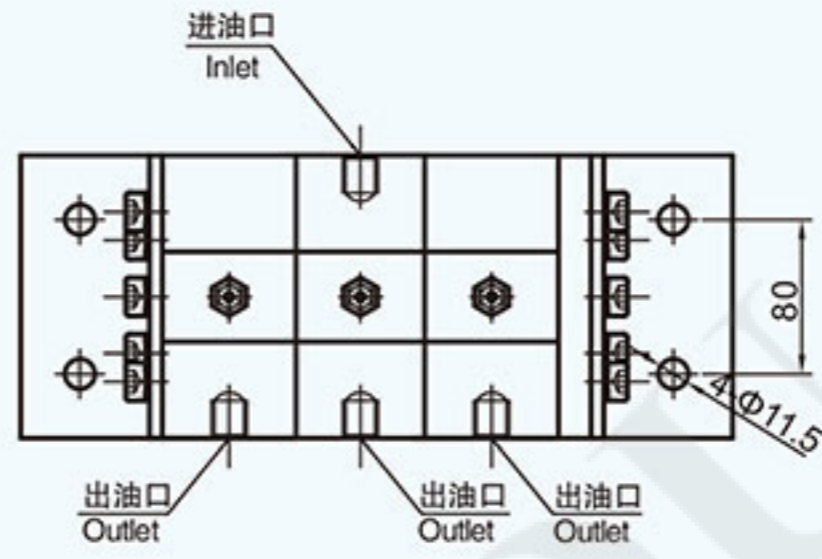

VCJ3R-**

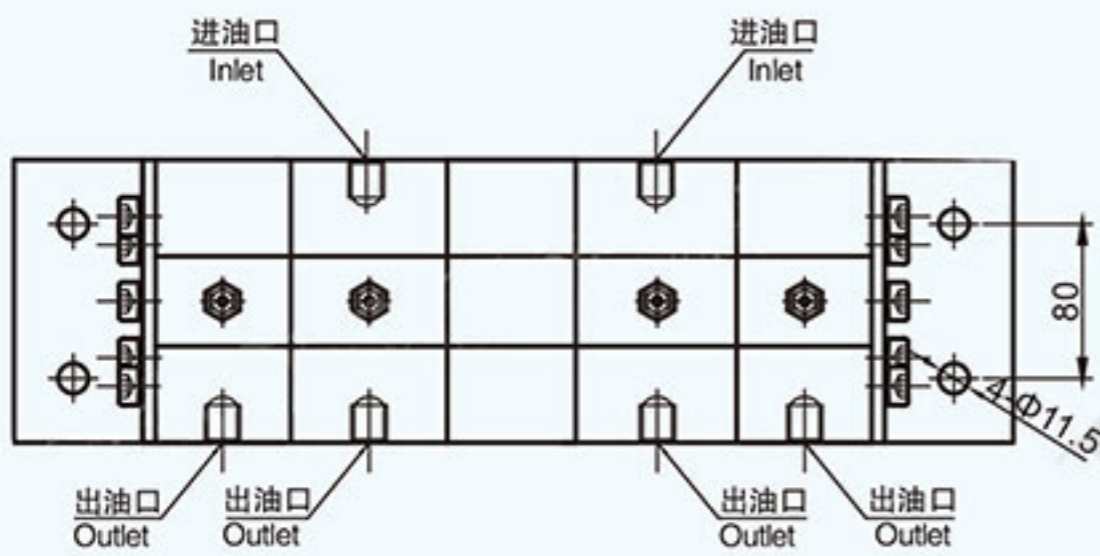

VCJ4R-**

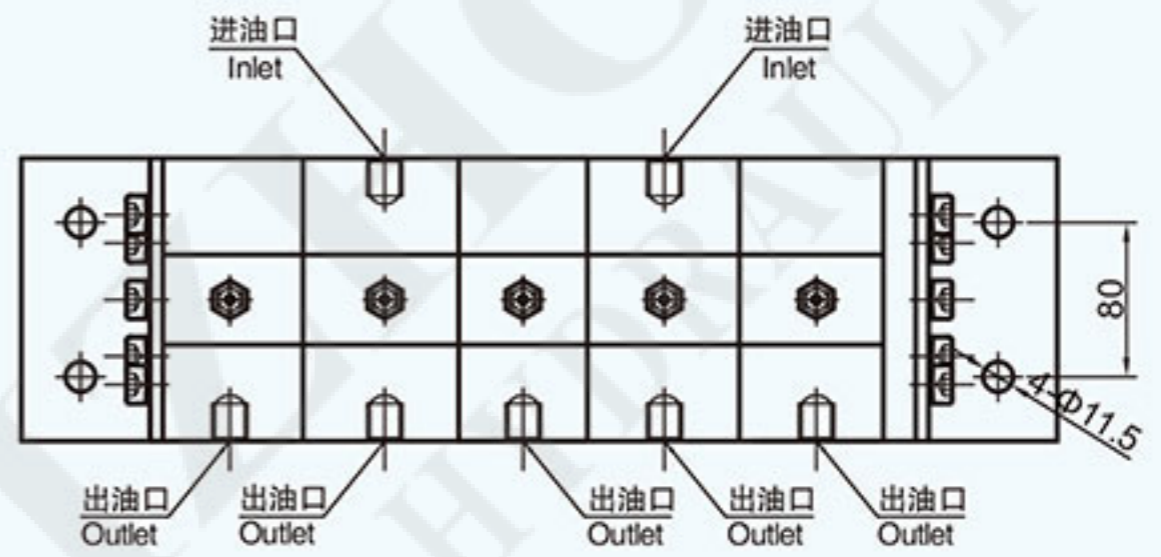

VCJ5R-**

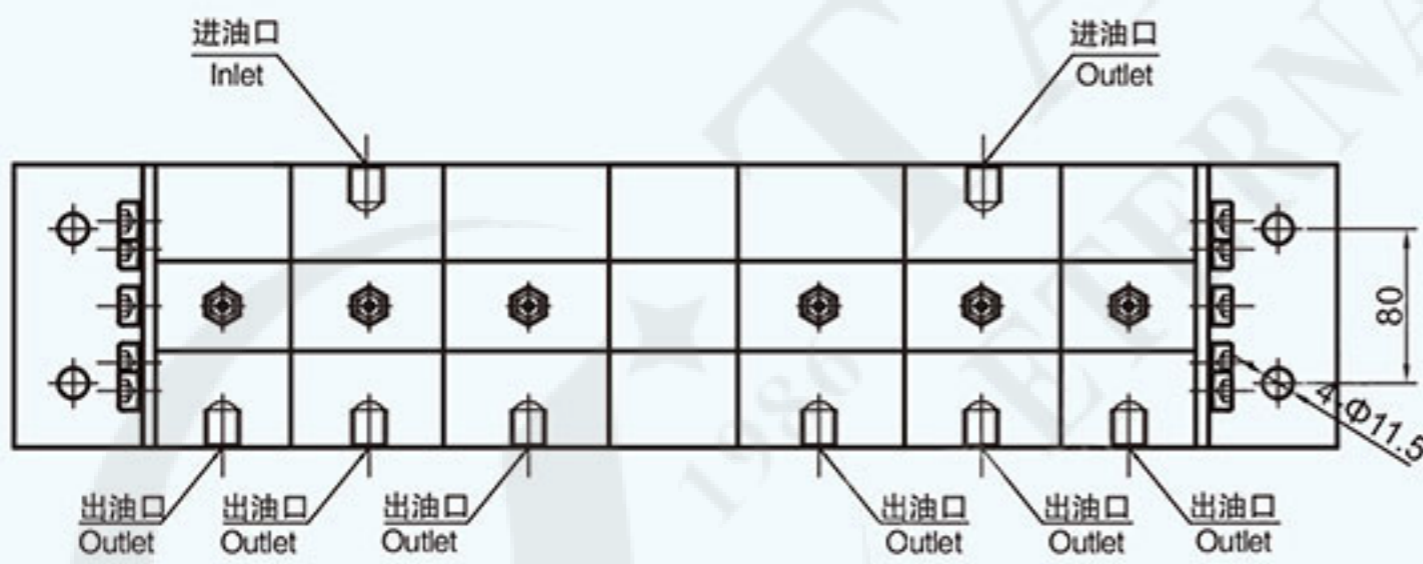

VCJ6R-**





齿轮泵和齿轮分流器使用注意事项

Precautions for using gear pump and gear diverter

- 1、泵的主动轴不允许承受径向力和轴向力(如:安装连接时花键套长度不得超过泵主动轴花键有效长度,动力轴端和联轴套不能与齿轮泵轴伸花键收尾和轴上台阶有任何轴向相抵存在)。特殊情况如存在径向力和轴向力工况请与公司联系特殊定货。
- 2、泵的主动轴与原动机输出轴的安装同轴度不得大于0.05mm,且泵支座的安装平面与止口的垂直度不得大于0.05mm。联轴套两端连接部分也应保证0.05mm以内的同轴度。
- 3、泵的吸油高度不大于0.5m,且进油管道通径应保证流速 $\leq 2\text{m/s}$,即进油管道通径 $d \geq 3.25\sqrt{Q}$ (毫米),其中Q为泵出口流量 $Q(\text{升})=q \cdot n$ 。
- 4、泵的进油管及法兰不应漏气。
- 5、工作油液应保持清洁,推荐在泵的吸油管安装过滤精度 $80 \sim 100 \mu\text{m}$ 的滤油器,回油管路安装过滤精度不小于 $25 \mu\text{m}$ 的滤油器,并且要根据油液污染情况定期清洗或更换。
- 6、泵进油方如有滤油器,则应保证滤油器有效通流量应大于泵最大吸油流量的两倍,并保持畅通,防止堵塞。
- 7、严格规定:在泵安装开始起动之前,必须注油排气,以便泵在开车转动时能及时吸上油。最好在压力管路中,松开一个管接头,点动力元件让油液流出来直到不见气泡为止,然后拧紧管接头(此操作应特别注意按此处理,泵未进行此项操作是初期损坏遇到最多的故障)。泵装机后应进行不少于10分钟的空载和短时间的负载运转。
- 8、泵在连续工作情况下最高温度不得超过 80°C ,瞬间工作温度不得超过 120°C ,以免引起密封件过早老化。
- 9、泵和油泵电机直接连接时,用手将泵轻轻推到泵的止口端面和电机法兰端面紧紧贴在一后,再用螺钉固定,如有间隙,必须清理内孔和轴表面异物,消除间隙,然后推进去,贴紧,固定。
- 10、用户不要随意调节同步分流器,先检查油管是否一样长,缸径,行程,活塞杆是否一样,管路一定不要焊接,安装后空载升降3-5次,正常后方可使用。

- 1、The driving shaft of the pump is not allowed to withstand radial force and axial force(That is ,during installation, the spline housing should no be longer than the effective length of the pump's driving shaft spline ;there should be no axial obstruction between the driving shaft end ,coupling sleeve and the gear pump axial spline end and shaft shoulder).In the case of any special condition such as radial force ,please contact with our company for special order.
- 2、The installing concentricity between the pump driving shaft and the prime-mover output shaft should not be more than 0.05mm,and the perpendicularity between the installation surface of the pump base and the pad should not be more than 0.05mm.The concentricity between the two ends of coupling sleeve should be within 0.05mm.
- 3、The pump's oil suction height should not be more than 0.5m and the inlet pipe should have a diameter to ensure flow rate no more than 2m/s, that is, the diameter of the inlet Pipe should be no less than 3.25(mm).Where Q is the pump outlet flow (liter)= $q \cdot n$.
- 4、No air leaking in the inlet pipe and flange .
- 5、The working oil should be kept clean .It is recommended to install a filter with filtrating accuracy of $80 \sim 100\mu\text{m}$ in the suction pipe of the pump and a filtrating accuracy no less than $25 \mu\text{m}$ in the outlet pipe .The oil should be cleaned or replaced in a regular way dependant on its dirtiness.
- 6、If the inlet port of the pump is equipped with a filter, make sure that the effective through-flow of the filter is at least three times the pump's maximum suction flow .Care must be taken to prevent blockage .
- 7、It is strictly stipulated that before starting pump, oil must be poured and air must be discharged to ensure that the pump can suck in oil timely when the pump is started .The best way is to loosen a pipe connector (This step is imperative as omission of this step is the principle reason for damaging pumps at the earlier stage) . After installation ,the pump should have at least ten minutes idle run and a short period of load run.
- 8、Under continual working condition ,the pump's highest working temperature should not exceed 80°C ,Instantaneous temperature no more than 120°C to guard against early of the sealing .
- 9、Pump and oil pump motor directly connected, the pump with te hand gently on the seam allowance of the pump end and motor flange end face tightly stick together, reoccupy screws, if there is a gap, foreign body must clean up the inner hole and shaft surface, eliminate the gap, and then advance to, tiejin, fixed.
- 10、Users do not freely adjust the synchronous shunt, check whether the tubing is the same length, cylinder diameter, stroke, Piston Rod is the same, the pipeline must not be welded, installed after lifting 3-5 times no load, normal rear can be used.